



# Installation Manual – Springs and Rockers

## Contents

Prepare the site.....	1
Equipment required for installation .....	1
Fasteners.....	2
Concrete.....	2
Base and Footing.....	2
Accessible Big Dipper Rocker.....	3
Accessible Dipper Rocker and Scuttle Rocker.....	3
Beach Buggy.....	3
Cast Away.....	4
Critter Rockers.....	5
Jitterbug.....	5
Multi Rocker .....	6
Quad Rocker .....	6
See-Saw and Twin Rocker .....	7
Single Rocker.....	8
Torpedo Rocker.....	10
Torpedo See Saw .....	10
Wave Rocker.....	11
Zephyr Rocker .....	12

## Prepare the site

Prior to any installation, you should be familiar with the requirements of AS 4685 – 2021 “Playground equipment – safety requirements and test methods” (particularly relating to fall zone requirements), AS/NZS 4422:2016 “Playground surfacing – specifications, requirements and test method” (relating to the type and depth of your soft-fall surfacing), and AS/NZS 4685.0:2017 “Playgrounds and playground equipment – development, installation, maintenance and operation” (dealing with your site requirements and ongoing maintenance).

- Check that the site is clear of underground power and services before you commence digging.
- Measure the site to ensure that it is large enough to allow for the correct fall zones between the equipment and the outside of the soft-fall surface, and for correct distances between various items of equipment. If you are unsure of these requirements you should check with your PlayCo representative.
- For ease of installation, do not put the soft-fall surfacing in until after the equipment has been installed. Ensure that you allow for the required soft-fall depth when excavating the site. Any excavation should take place prior to commencing the installation of the equipment.

## Equipment required for installation

1. Ratchet (or socket set) with ½” driver
2. Ratchet (or socket set) with 3/8” driver
3. Cordless drill
4. Shovel for digging holes (preferably long-handled)
5. If digging in hard ground you may need a 300mm auger and a crowbar
6. Spirit level
7. Concrete for footings

## Fasteners

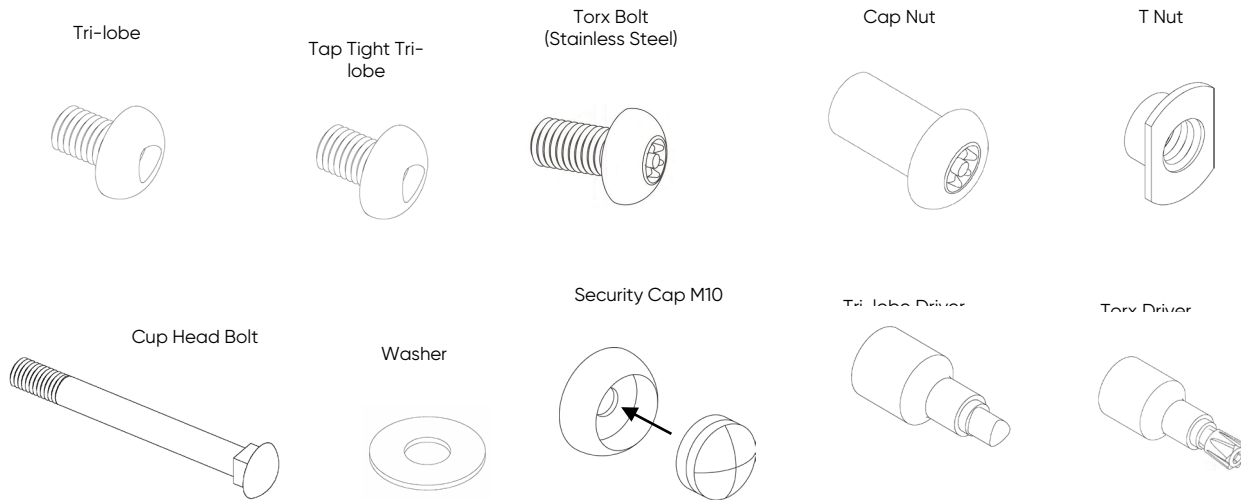

## Concrete

PlayCo recommends General Purpose Concrete. This is a concrete with a compressive strength of 20MPa (at 28 days) or higher.

The concrete used in playground footings should only be mixed and/or worked by a suitably experienced person following supplier/manufacturer's instructions.

## Base and Footing

Dig 350mm diameter hole, 800mm deep. Concrete the animal stand (base) into the ground making sure that the top will be level with the proposed finished surface level. Concrete footing should be 350mm diameter and be 500mm deep. Leave the concrete to set for at least 24 hours before bolting the spring onto the stand.

If the surface is concrete, instead of animal stand (base) use supplied base plate. Place the plate on right place, mark the square holes on the concrete surface and use a concrete drill or a chisel to dig the marking on the concrete 5mm deep to allow room for the spring holding nuts. Use eight M12 DIN bolts for bolt down.

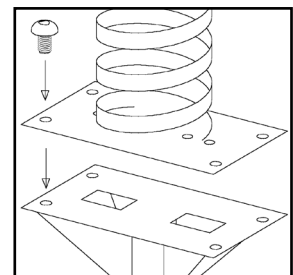

## Accessible Big Dipper Rocker

All parts are preassembled.

Place the frame on top of the spring, fasten using 20mm Tri-lobe bolts on the bottom.

Keep the leg vertical when installing.

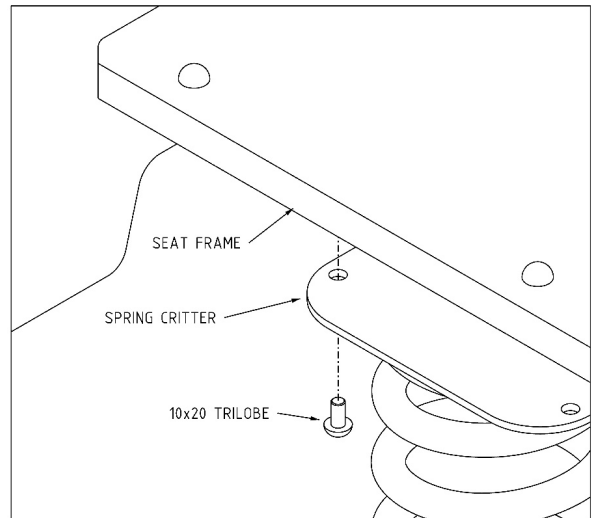

## Accessible Dipper Rocker and Scuttle Rocker

All parts are preassembled.

Place the frame on top of the spring.

Fasten using 10x28 Cap Nuts from the top and 10x30 cup head bolts on the bottom.

Keep the leg vertical when installing.

## Beach Buggy

Dig 4 300mm holes 600mm deep in 632 x 1400mm square as shown. Attach springs to frame and animal stands (base). Position as per plan and concrete the 4 animal stands (base) into the ground making sure that the top will be level with the proposed finished surface level. Concrete footings must be no less than 300mm diameter and should be 600mm deep, extending to the base plate. Remove frame with springs. Leave the concrete to set for at least 24 hours before bolting the springs (22mm) onto the animal stands (base).

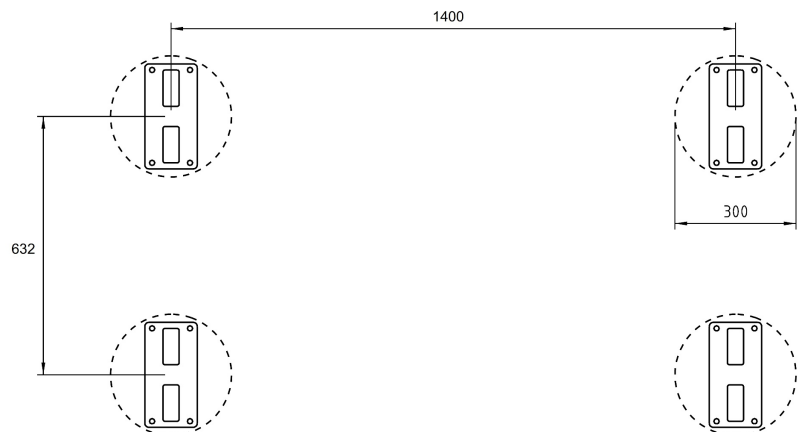

Assemble the top sections of the item as shown.

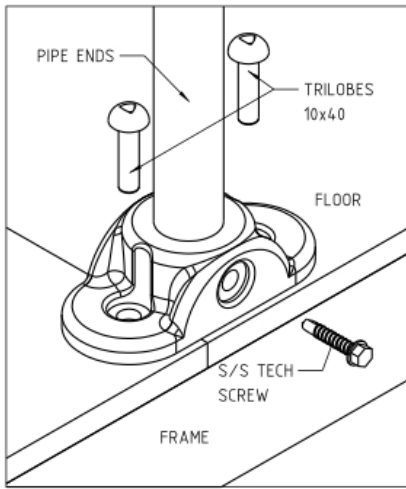

Use Loctite for all bolts.

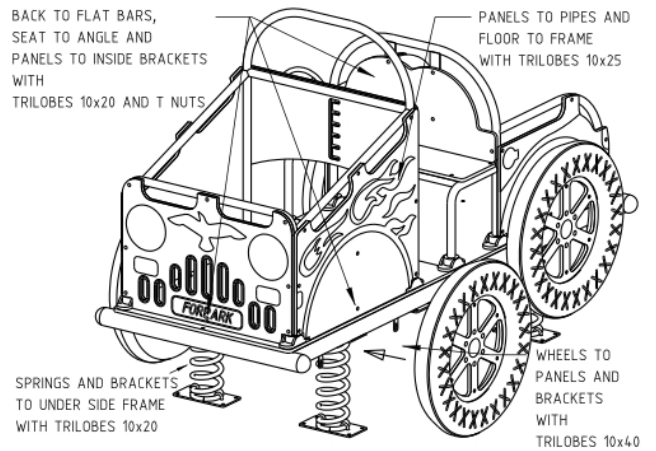
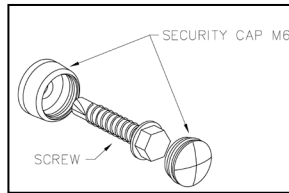

### Cast Away

Dig 3 300mm holes 600mm deep in a distance as shown. All parts above springs are preassembled. Attach springs to frame with tri-lobes 10x20 and animal stands (base) to springs. Position as per plan and concrete the 3 animal stands (base) into the ground making sure that the top will be level with the proposed finished surface level. Concrete footings must be no more than 300mm diameter and should be 600mm deep, extending to the base plate. Remove frame with springs. Leave the concrete to set for at least 24 hours before bolting the 2 springs (20mm) and one spring (24mm) onto the animal stands (base).

Use Loctite for all bolts.

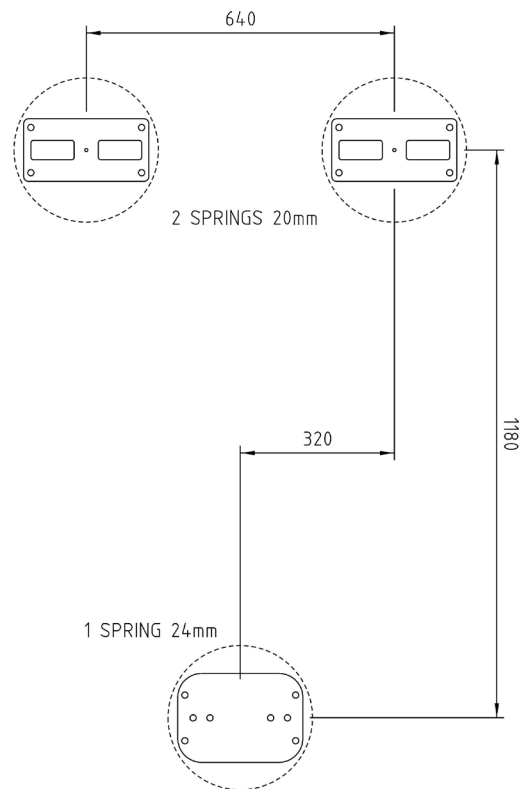
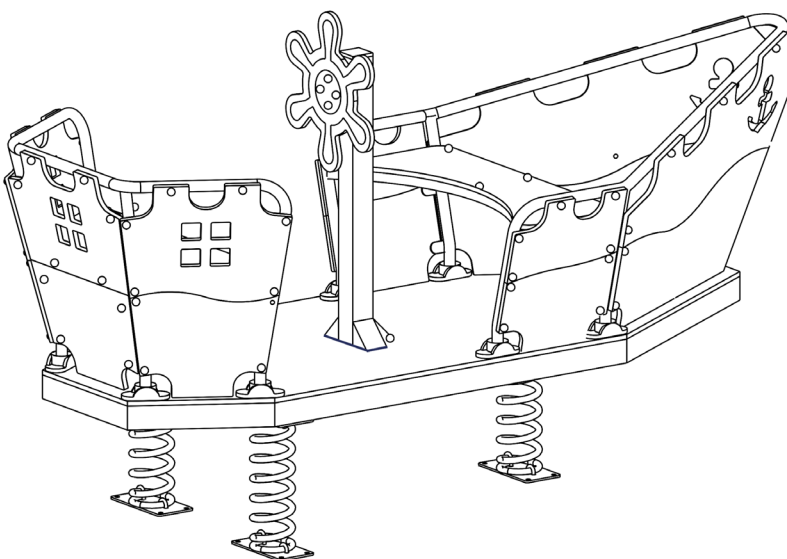
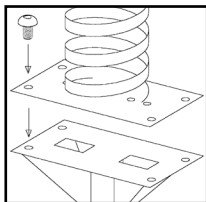

## Critter Rockers

Install the animal stand (base) as described under Single Rockers. Leave the concrete to set for at least 24 hours, then attach the spring (24mm) using 'tap tight' tri-lobes.

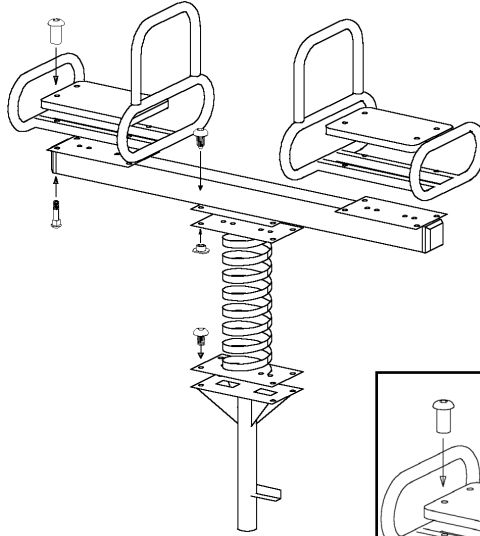

## Single Critters

Place the frame on top of the spring, place the seat on top of the frame and fasten using 40mm cup head bolts and aluminium cap nuts.

## Double and 4-Way Critters

Place the beam on top of the spring (24mm) and fasten using 17mm tri-lobes, washers and T-nuts. Place the frames on top of the beam, place the seats on top of the frames and fasten using 40mm cup head bolts and aluminium cap nuts.

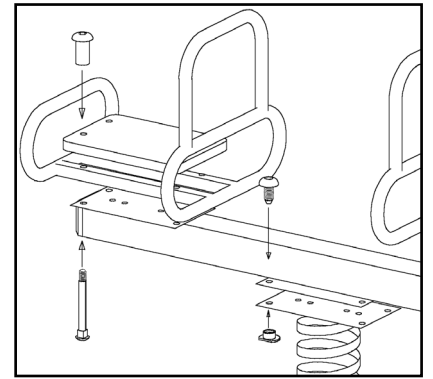

## Jitterbug

Concrete the animal stand (base) into the ground making sure that the top will be level with the proposed finished surface level. Concrete footing must be no more than 300mm diameter and should be 600mm deep, extending to the base plate. Leave the concrete to set for at least 24 hours before bolting the spring (22mm) onto the stand.

Assemble the top section of the item as shown and attach to the spring.

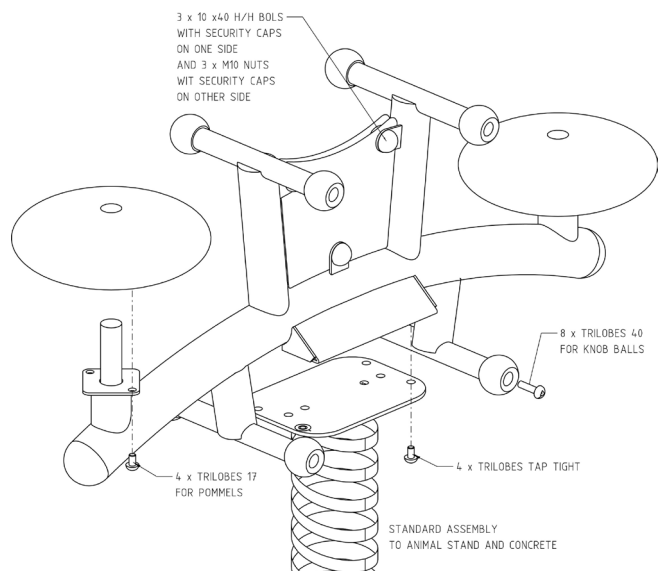
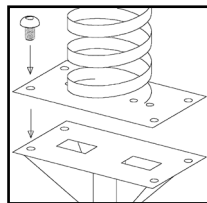

## Multi Rocker

Attach the two 65mm x 65mm beams to the springs (22mm), ensuring that the sides with the holes on the insides are closest together. Use the springs to determine the correct position for the animal stands (bases) and concrete both stands into the ground as described above (Base and Footings). Leave the concrete to set for at least 24 hours, then attach the springs to the stands using 'tap tight' tri-lobes. Assemble the rest of the Multi Rocker the same as described under 'See Saw', using 130mm cup head bolts and stainless steel cap nuts through the intersecting beams.

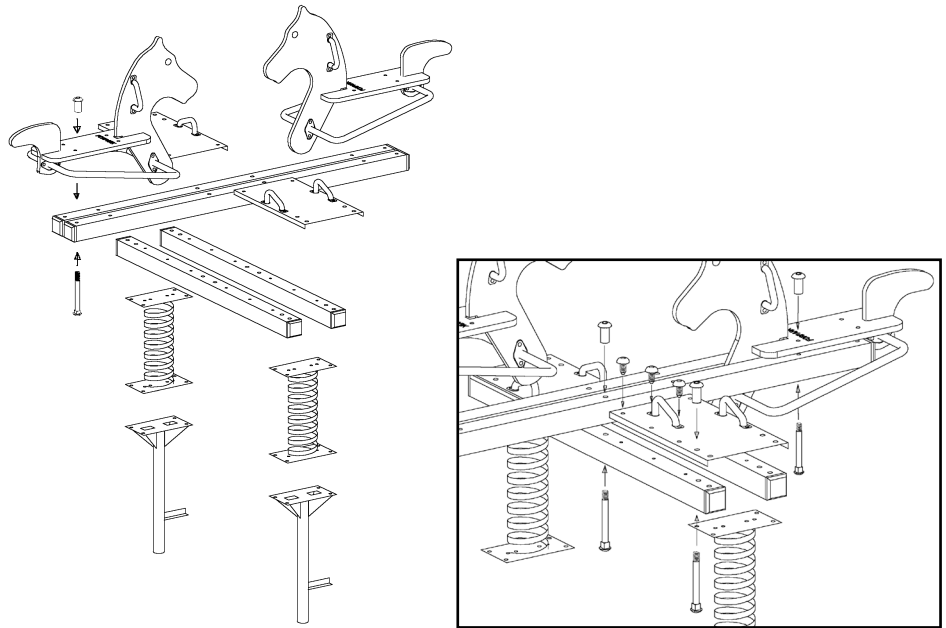

## Quad Rocker

Concrete the four animal stands (bases) into the ground as described above (Base and Footings), fastening each stand to the 'cross plate' in order to position the stands correctly. Leave the concrete to set for at least 24 hours, then remove the cross plate and attach the springs (22mm) to the stands using 'tap tight' tri-lobes. The top section of the Quad Rocker is assembled in the same way as the See Saw with the following variations. The crossbeams are attached to the main beams using 'tap tight' tri-lobes. The cross plate should be fastened across the top of the beams at the same time the beams are attached to the spring plate using 80mm cup head bolts and stainless steel cap nuts.

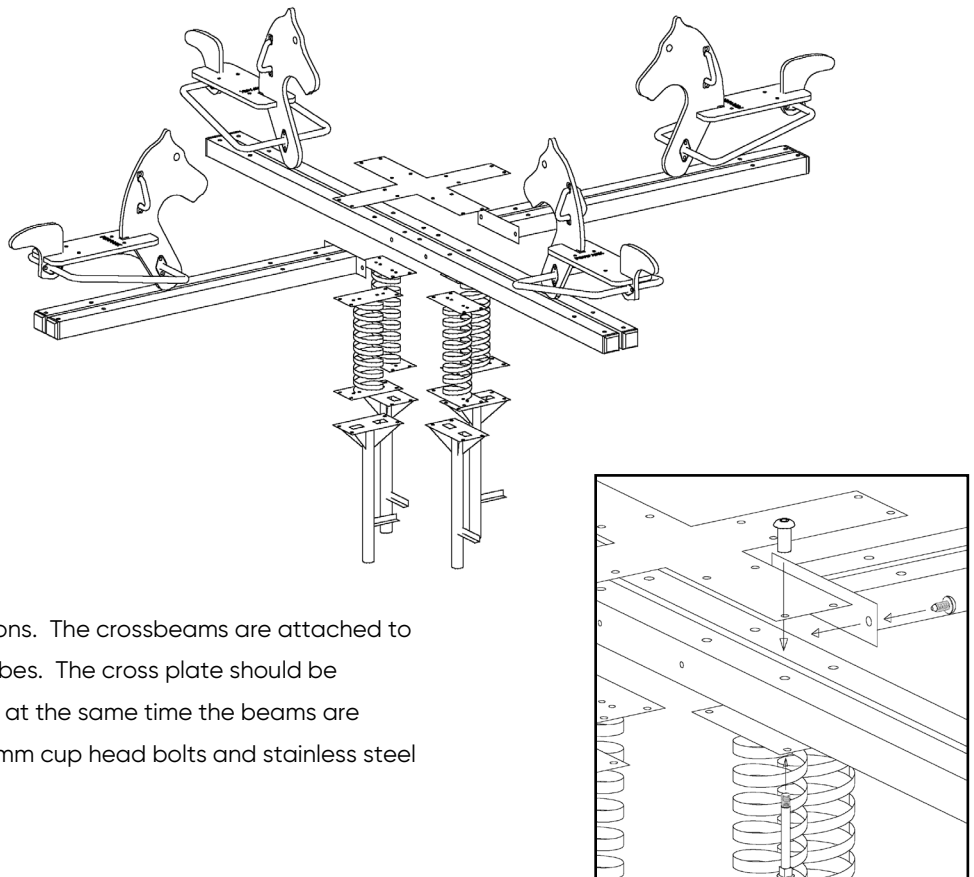

## See-Saw and Twin Rocker

Concrete the two animal stands (bases) into the ground as described above (Base and Footings), using the spring (22mm) as a template to position the two correctly. Leave the concrete to set for at least 24 hours before attaching the springs to the stands using 'tap tight' tri-lobes. The See Saw spring has a pivot and the twin rocker spring does not. Place the two beams side by side then bolt onto the spring using 70mm cup head bolts and stainless steel cap nuts. The Twin Rocker beams fit across the spring and the See Saw beams fit along the spring. Twin Rockers have a cover plate that fastens to the spring plate on either side of the beams to cover protruding bolts. Assemble the animal shapes as described under "Single Rockers", fitting the shapes in-between the beams. Fasten the seats to the beams using 100mm cup head bolts and cap nuts di cast.

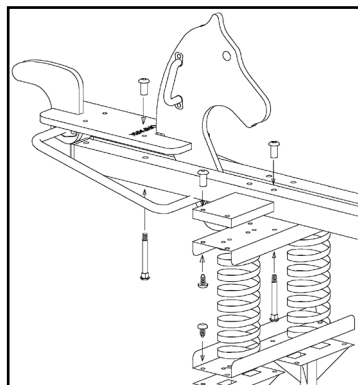
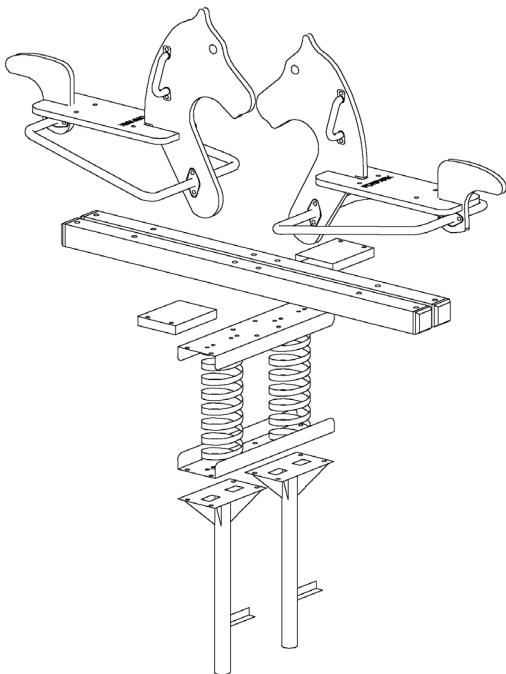
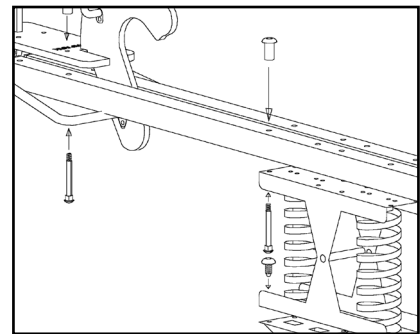
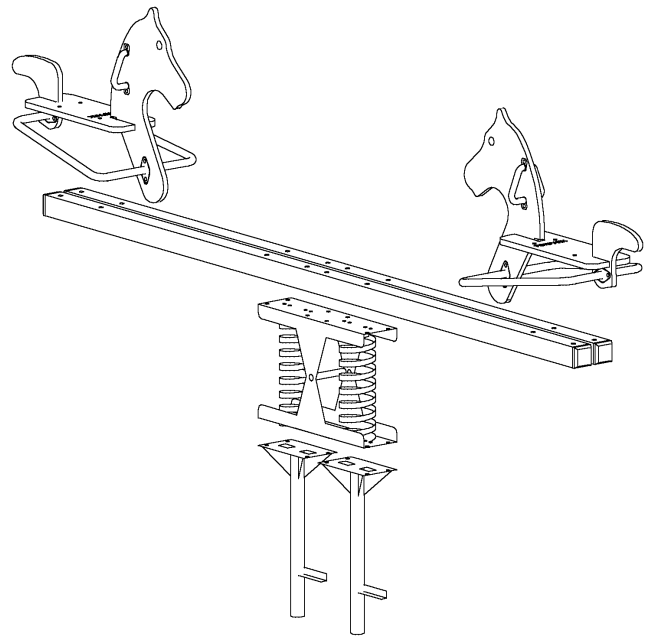

## Single Rocker

### Single Shape

Bolt the spring (22mm) onto the stand using 'tap tight' tri-lobes. The seat has a slot in each end. The longest slot fits onto the head shape. Fit the head and tail shapes onto the seat then fasten the seat to the spring using 30mm cup head bolts and stainless steel cap nuts (with the cap nut pointing down through the seat). Attach the stirrups to the head and tail using 17mm tri-lobes and aluminium cap nuts.

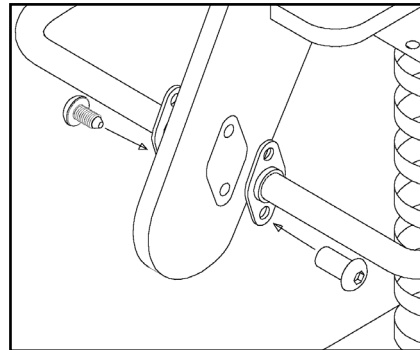
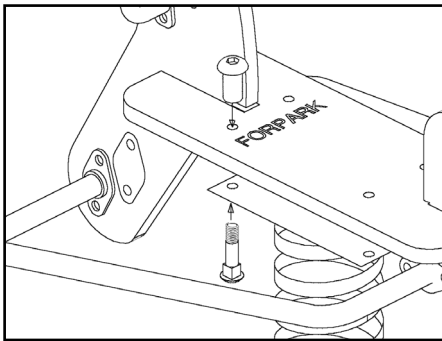
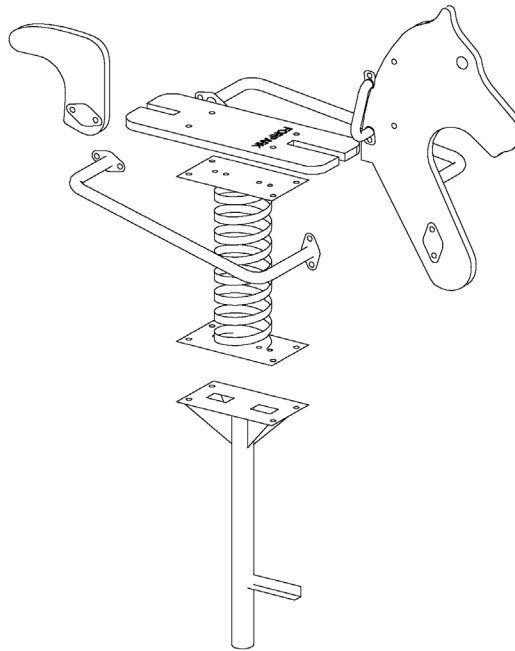

## Double Shape

Bolt the spring (22mm) onto the stand using 'tap tight' tri-lobes. Assemble the top section of the rocker, bolting the shapes to the seat and rails. Rails and seats attach to the sides using 17mm tri-lobes and aluminium cap nuts on cast aluminium shapes, and T-nuts instead of cap nuts on the plastic shapes. Add a washer to the bolts attaching the seats to the side shapes. Position the assembled top section onto the spring and fasten to the spring using 30mm cup head bolts and stainless steel cap nuts (with the cap nut pointing down through the seat).

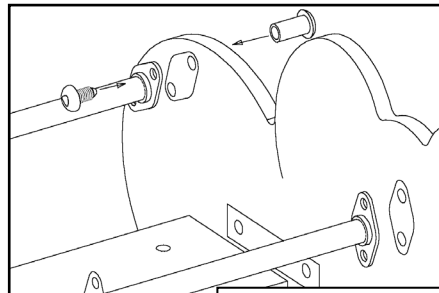
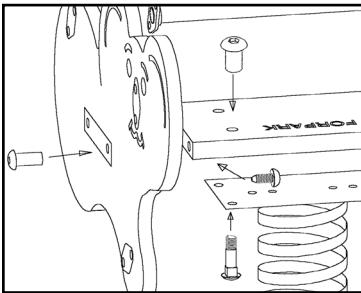
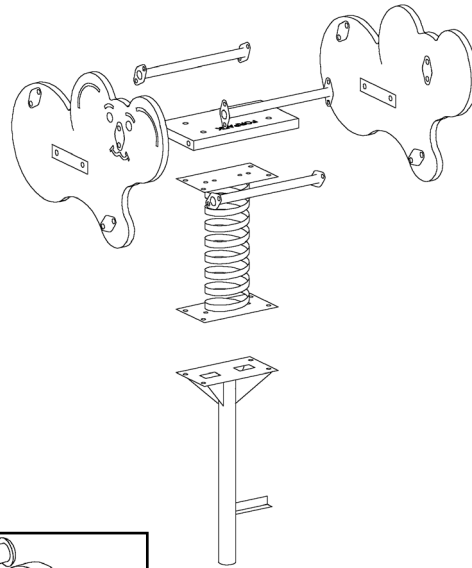

ALUMINIUM SIDES

When there are plastic panels use for seat attachment S/S cap nuts with S/S washers 1/2" on panel side and trilobes 10x25 with S/S washers M10 on seat casting side as shown. Use tri-lobes 10x17 and T-nuts for rails as shown.

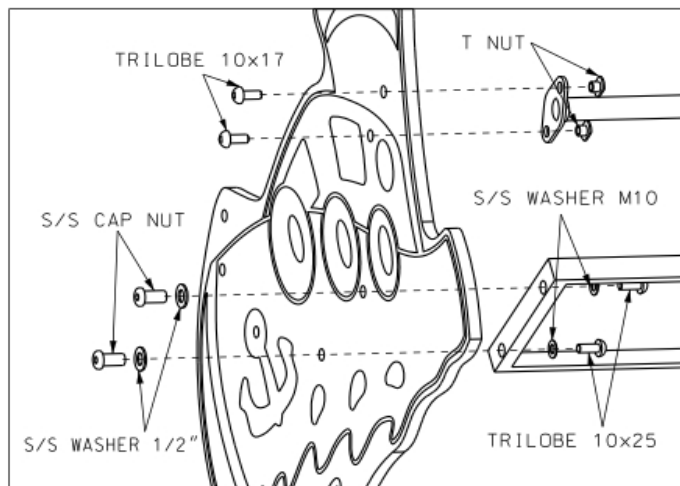

## Torpedo Rocker

Concrete the animal stand (base) into the ground making sure that the top will be level with the proposed finished surface level. Concrete footing must be no less than 300mm diameter and should be 600mm deep, extending to the base plate. Leave the concrete to set for at least 24 hours before bolting the spring (22mm) onto the stand.

Assemble the top section of the rocker as shown and attach to the spring.

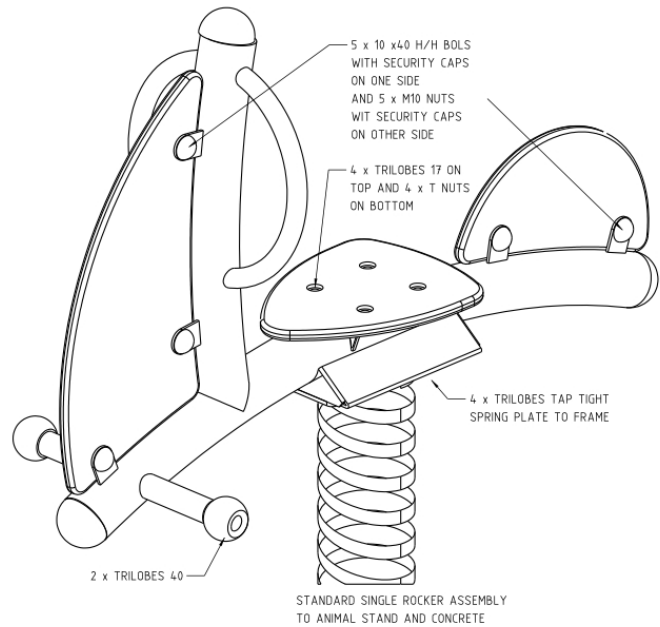
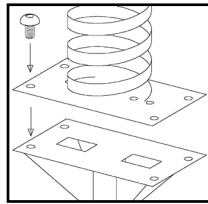

## Torpedo See Saw

Concrete the torpedo see saw upright (base) into the ground making sure that the top is level and positioned 400mm above the proposed finished surface level. Concrete footing should be 500mm x 500mm x 500mm deep as shown. Leave the concrete to set for at least 24 hours before bolting the see saw onto the base.

Assemble the top section of the see saw as shown and attach to the upright.

All 8 bolts z/p soc screw must be well tightened and secured with Loctite.

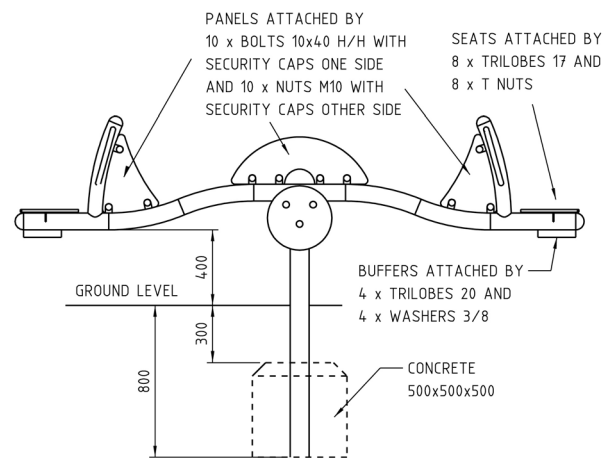
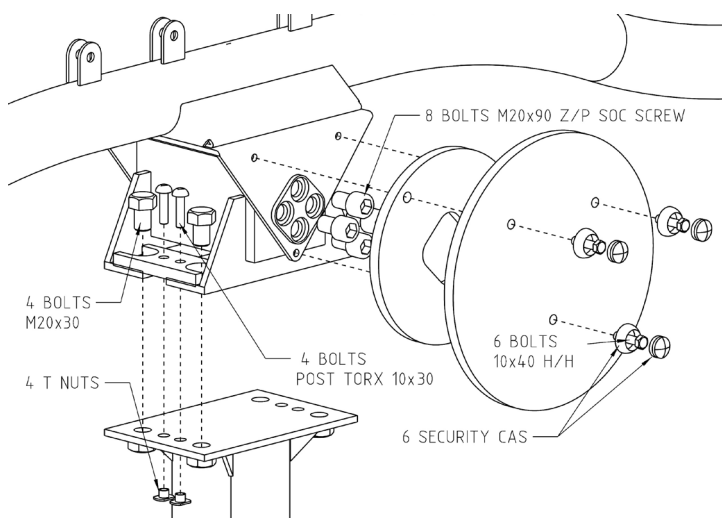

## Wave Rocker

Dig a single hole 800mm deep (below the finished surface level) and 500mm square. Insert the upright in the hole, making sure it is level, with the top 220mm above the finished surface level as shown.

Pour concrete around the base of the pole forming a footing of 500mm x 500mm x 500mm, the top being 300mm below the finished surface level with a tapered top so that water won't pool around the upright. Check levels again after the concrete is poured.

Leave the concrete to set for at least 24 hours before connecting the Wave Rocker top.

Assemble the top section as shown. All 8 bolts z/p soc screws must be well tightened and secured with Loctite. Once the concrete has set, lift the top section and place on top of the upright and attach as shown.

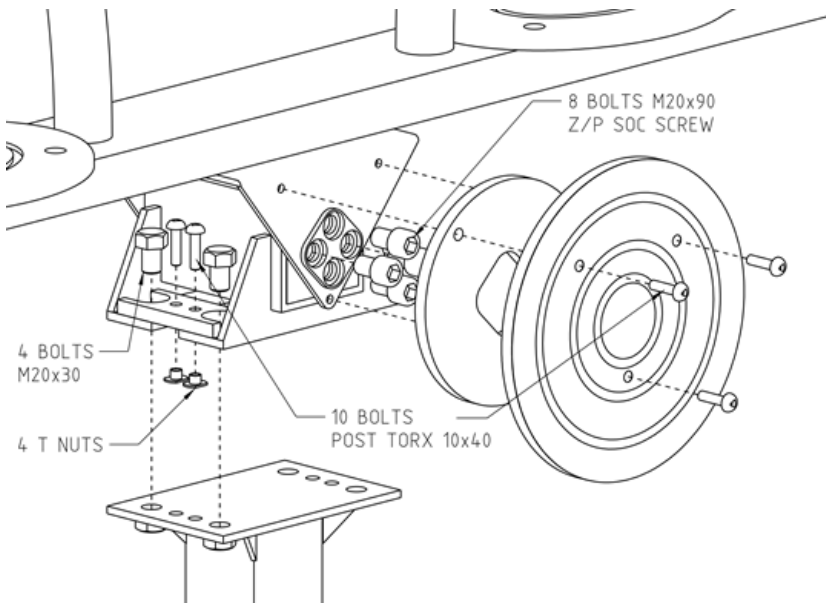
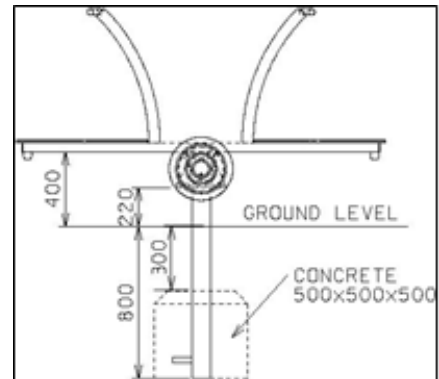
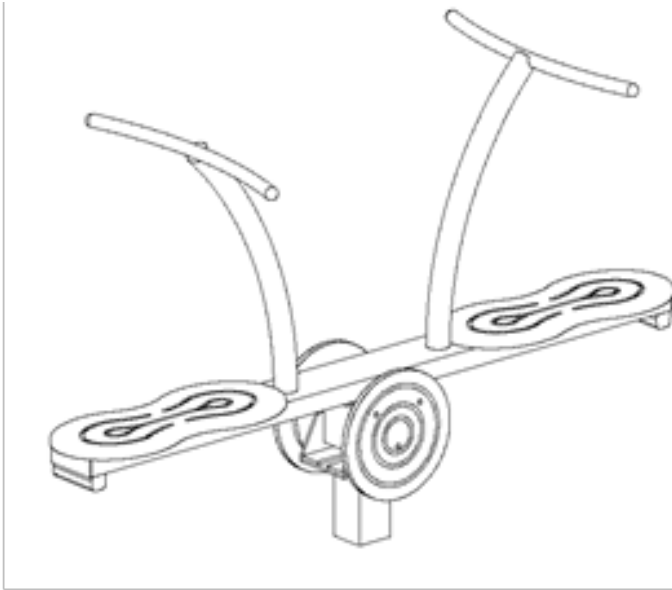

## Zephyr Rocker

All parts are preassembled.

Keep the leg vertical when installing.

