



Installation Manual – Fitness Track

Contents

Prepare the site.....	1	FT44 – Steppers	26
Equipment required for installation	1	FT50 –Parallel Bars (Heavy)	26
Securing the site while work is in progress	1	FT51 – Dip Bars	26
Preparation for installation	2	FT52 – Unders & Overs	27
Concrete Footings	2	FT55 – Ninja Step	27
Fasteners.....	2		
Flanges & Rails	3		
FT01a – Chin Up Bar ‘A’	3		
FT01b – Chin Up Bar ‘B’	4		
FT02 – Log Wall	4		
FT03 & FT36 – Rope Swing / Rope Climber	5		
FT04 – Leap Frog	6		
FT05 – Monkey Bars	6		
FT06 – Obstacle Frame.....	7		
FT07 – Sit Up Board.....	7		
FT08 – Chain Net & Frame	8		
FT09 – Parallel Bars	8		
FT10 – Hurdles	9		
FT11a – Balance Walkers ‘A’	9		
FT11b – Balance Walkers ‘B’	9		
FT12 – Swinging Balance Beam.....	10		
FT13 – Step Up.....	11		
FT14 – Roman Triangles.....	11		
FT15 – Fireman’s Pole	12		
FT16 – Roll Over Bar	12		
FT17 – Achilles Stretch.....	13		
FT18 – Push Up Bars.....	13		
FT19 – Vault Bar.....	14		
FT20 – Leg Lift Bar	14		
FT23 – Burmese Bridge.....	15		
FT24 – Challenge Rail	16		
FT25 – Arched Roman Triangles.....	16		
FT26 – Hang ‘n’ Glide.....	17		
FT28 – Vertical Rung Climber	17		
FT29 – TreadMill	18		
FT30 – Combat & Rung Climber.....	19		
FT31 – Commando Climber.....	20		
FT32 – Pommel Walker	21		
FT33 – Rock Wall & Pole.....	22		
FT34 – Arched Monkey Bar	23		
FT35 – Roman Monkey Bar.....	23		
FT39 – Double Sided Rock Wall.....	24		
FT40 – Aerobic Stepper	24		
FT42 – Stretch Station.....	25		
FT43 – FT Sign	25		

Prepare the site

- Fitness Track equipment is normally designed for installation on a flat level surface so you should ensure that the proposed area is prepared correctly.
- Check that the site is clear of underground power and services before you commence digging.
- If soft-fall surfacing is to be used below the equipment, for ease of installation do not put the soft-fall surfacing in until after the equipment has been installed. Ensure that you allow for the required soft-fall depth when excavating the site. Any excavation should take place before commencing installation of the equipment.
- Before you commence installation, you should lay out the equipment and ensure that you have all items detailed on the materials or packing list.

Equipment required for installation

1. Ratchet (or socket set) with ½" driver
2. Ratchet (or socket set) with 3/8" driver
3. Cordless Drill
4. Shovel for digging holes (preferably long-handled)
5. If digging in hard ground you may need a 300mm auger and a crowbar
6. Spirit level
7. 'G' clamps (for holding items in place before bolting)
8. Stringline
9. 'Vice-grip' pliers (for closing 'S' hooks)
10. An axe (for cutting tree roots if they are in the way)
11. Concrete for footings
12. Bricks/pavers (to provide stability below ground where required)
13. A basic first aid kit for emergencies
14. 'Occupational Health and Safety' plan and procedures if applicable

Securing the site while work is in progress

You should ensure that the worksite is clearly defined by some sort of barrier or temporary fence to ensure that children or onlookers are not in danger of injury while you work. The concrete footings will need at least 24 hours to set so a barrier or fence will keep people off the equipment until it is ready to be used and until adequate soft-fall surfacing has been installed.

Preparation for installation

1. Before you commence installation, you should lay out the equipment and ensure that you have all items detailed on the materials or packing list. (Each upright is numbered at the base in accordance with the numbering on the plan.)
2. Group the uprights for each piece of equipment together, along with the attaching items.
3. Layout the equipment roughly on the ground to ensure that it fits within the prepared area.
4. Determine the proposed finished surface level and use a string line to set this level. This will help in ensuring that the items are set at their correct height above ground level.

Concrete Footings

Concrete should be used on all items in the ground as per the diagram. Generally, the footing should be 300mm x 300mm x 500mm (deep) with a tapered tip so that water won't pool around the upright. Where loose-fill surfacing is used ensure that the concrete is 400mm below the finished surface level or that the footing is effectively covered by items of equipment in such a way that they do not present a hazard. (Note: If the ground is soft or likely to be subject to settling it is best to use an additional 100mm of concrete on the footing below the upright.) Most legs will extend around 800mm below ground but may vary so the depth in ground should be determined by the height of the upright above finished ground level as indicated in these instructions.

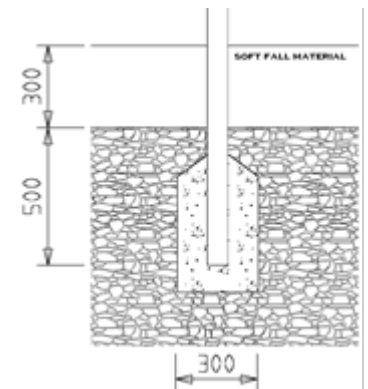

Forpark recommends General Purpose Concrete. This is concrete with a compressive strength of 20MPa (at 28 days) or higher.

The concrete used in playground footings should only be mixed and/or worked by a suitably experienced person following supplier/manufacturer's instructions.

Fasteners

Tri-lobe Bolt

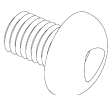

Torx Bolt

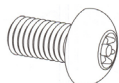

Cap Nut

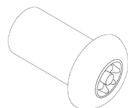

T Nut



Cup Head

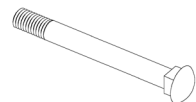

Tech Screw



Security Cap M6
For Tech Screws



S Hook



Tri-lobe Driver

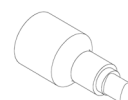

Torx Driver



Flanges & Rails

Most of the rails connect to the uprights using moulded plastic flanges. These flanges will be included in the bolt packs.

Connect the flanges to each end of the component to be attached to an upright using a tech screw. A security cap should be used with each tech screw as shown, fitting the base to the screw before fastening. The tech screw is inserted through the dimpled hole in the side of the flange and into the steel pipe using a power drill and the tech screwdriver supplied. Once secure, the top of the security cap should be securely fastened. Each flange is then connected to the uprights using two 20mm tri-lobes (in some instances 25mm tri-lobes will be supplied and can be used).

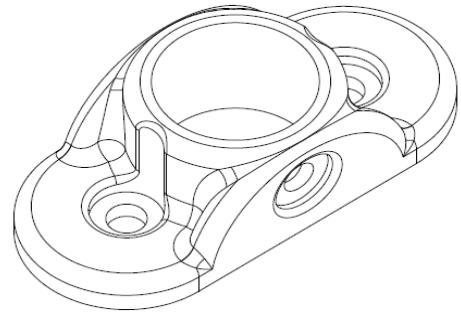

The flanges can be fastened to the rails before attaching to the uprights. In some cases, it may be easier to loosely fit the flanges in place on the rails then fasten the flanges to the upright. Once satisfied that the uprights are square the flanges can be secured to the component using tech screws.

Where rails are used to determine the distance between platforms a tape measure should also be used to allow for movement in the flanges if they are not yet secured.

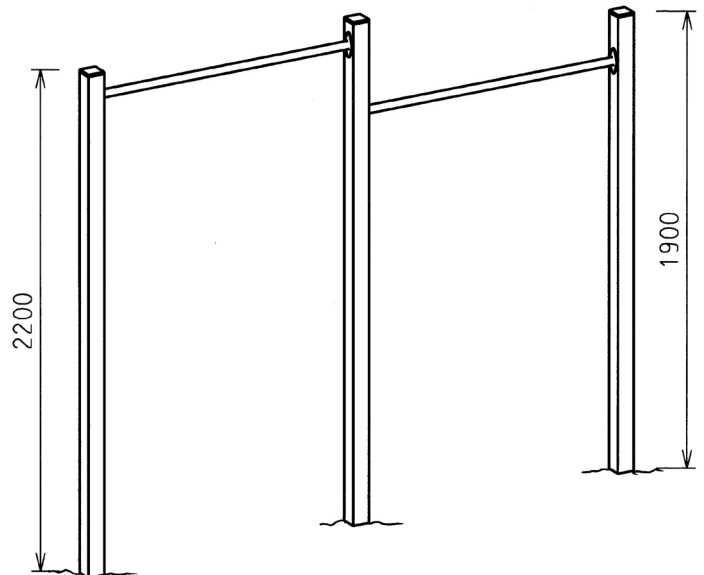
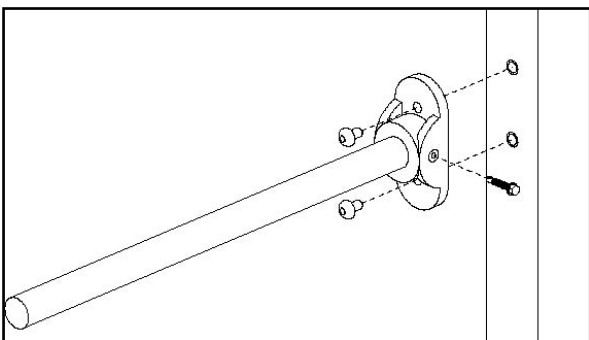

FT01a – Chin Up Bar ‘A’

Using the 1200mm length chin up rails (5274) as a guide to determine the distance between uprights, dig holes for the uprights. After placing the uprights in the holes and ensuring that their depth is correct (so that the height of the upright which extends above the finished ground level is as indicated in the drawing), attach the flanges to the rails and fasten the chin-up bars to the uprights. After ensuring that the uprights are vertical, the rails horizontal and the bolts are tightened, concrete the uprights into the ground. Fill the top of the holes with soil, packing firmly.

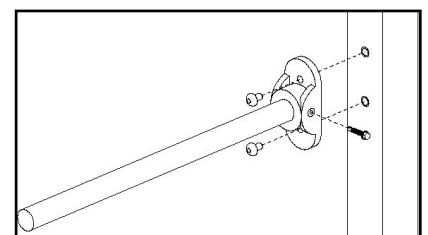
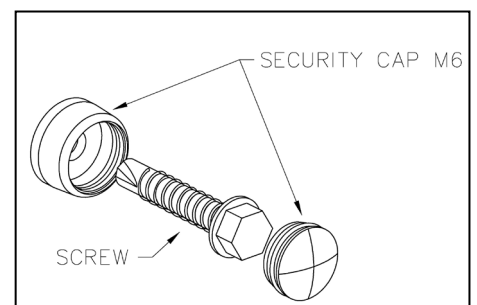

FT01b – Chin Up Bar 'B'

Install following the same instructions as FT01a above.

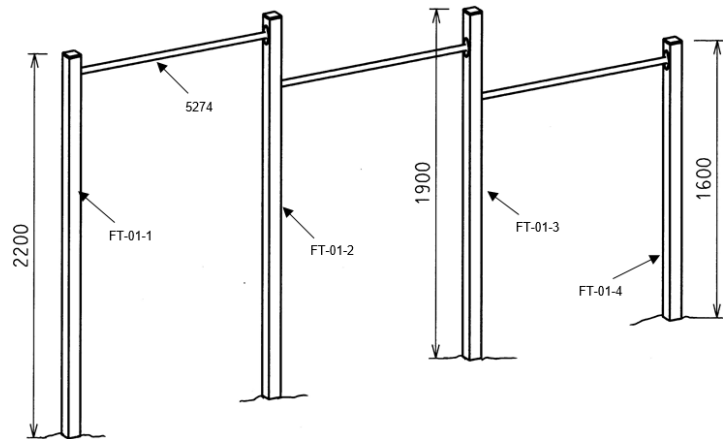

FT02 – Log Wall

Using the 1650mm length rails (5576 or 5575) as a guide to determine the distance between uprights, dig holes for the uprights. After placing the uprights in the holes and ensuring that their depth is correct (so that the height of the upright which extends above the finished ground level is as indicated in the drawing), attach the flanges to the rails and fasten the rails to the uprights. After ensuring that the uprights are vertical, the rails horizontal and the bolts are tightened, concrete the uprights into the ground. Fill the top of the holes with soil, packing firmly.

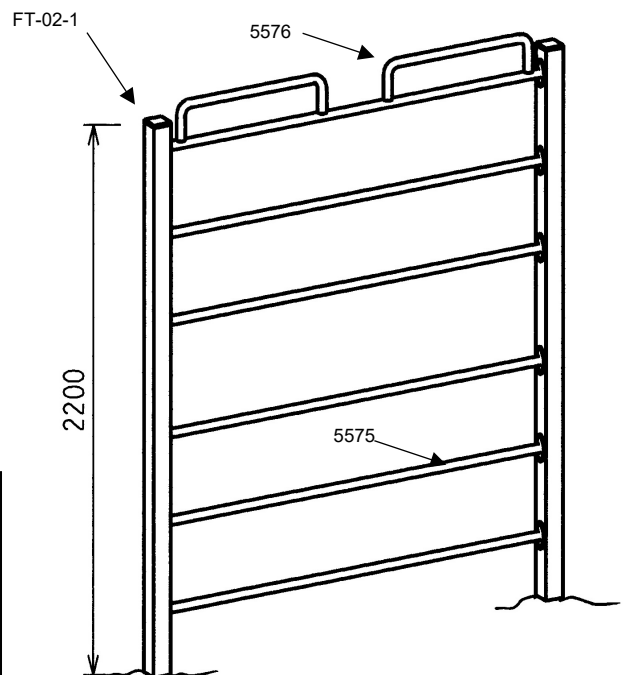
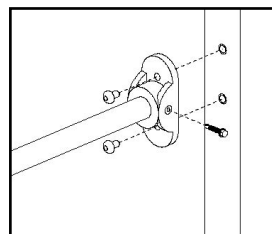

FT03 & FT36 – Rope Swing / Rope Climber

The frame is best assembled before installation. Assemble the frame while laying on the ground then roll into the upright position. The uprights (6112) are fastened to the top bar (FT-15-1) using 25mm tri-lobe bolts. Where tie bars (5896) are used they are fastened to the uprights using a 130mm threaded stud with stainless steel cap nuts on both ends. Use the frame in its upright position to determine the correct hole position and dig the holes. Lower the frame into the holes, ensuring that the top bar is level and at the correct height (2.5m above the finished surface level). After ensuring that all bolts are tightened, concrete the uprights into the ground. Fill the top of the holes with soil, packing firmly.

Dig another hole for each knotted rope to a depth that allows them to hang straight down. Concrete the anchors at the base of the ropes into the ground so that they hang virtually straight.

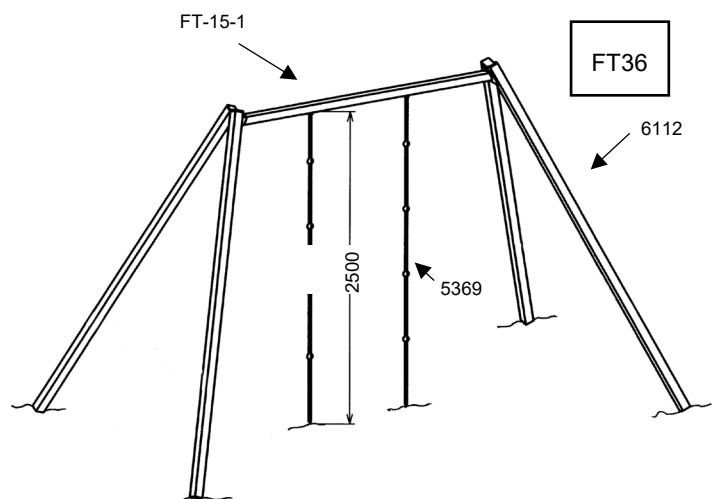
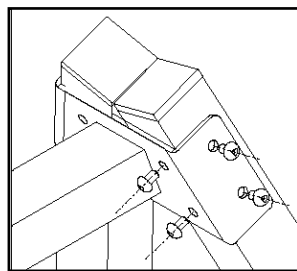
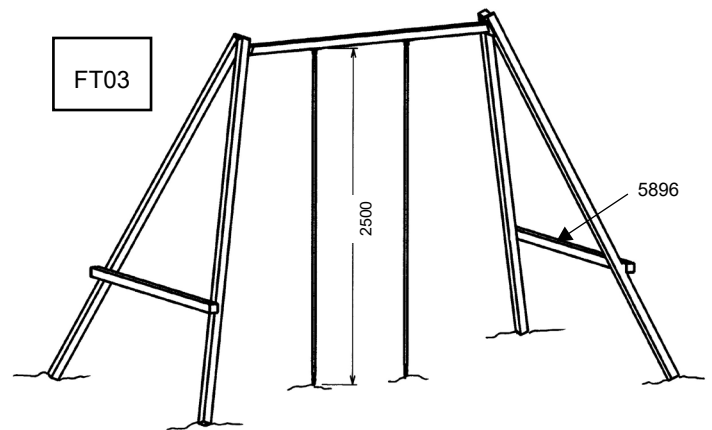

FT04 – Leap Frog

Fasten steppers to the uprights using 17mm tri-lobes. Dig holes for each upright. The leap frogs can be arranged in varying configurations but the distance between each should be uniform. Our recommended distance between each post is approximately 4 metres. After placing the uprights in the holes and ensuring that their depth is correct (so that the top of the leap frog extends 650mm above the finished ground level as indicated in the drawing), ensure that the uprights are vertical and concrete them into the ground. Fill the top of the holes with soil, packing firmly.

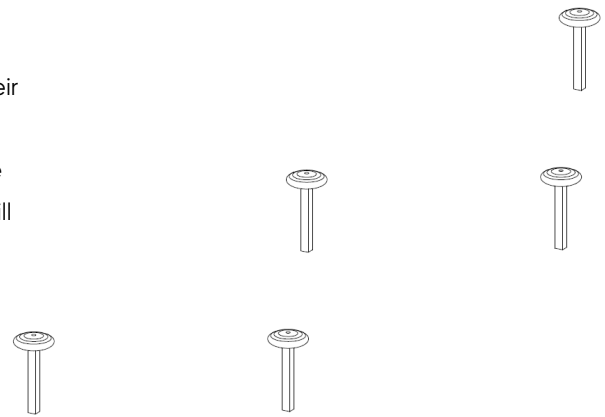

FT05 – Monkey Bars

Using the Monkey Bar (5053) as a guide to determine the distance between uprights, dig holes for the 4 uprights. Place the uprights in the holes and ensuring that their depth is correct (so that the height of the upright which extends above the finished ground level is as indicated in the drawing). Attach the flanges to the Monkey Bar, lift them into place and fasten to the uprights. Attach flanges to the rungs (5078) and fasten to the uprights. Attach and the support legs (5836) using a tap-tight tri-lobe bolt.

After ensuring that the uprights are vertical, the rails horizontal and the bolts are tightened, concrete the uprights into the ground. Fill the top of the holes with soil, packing firmly.

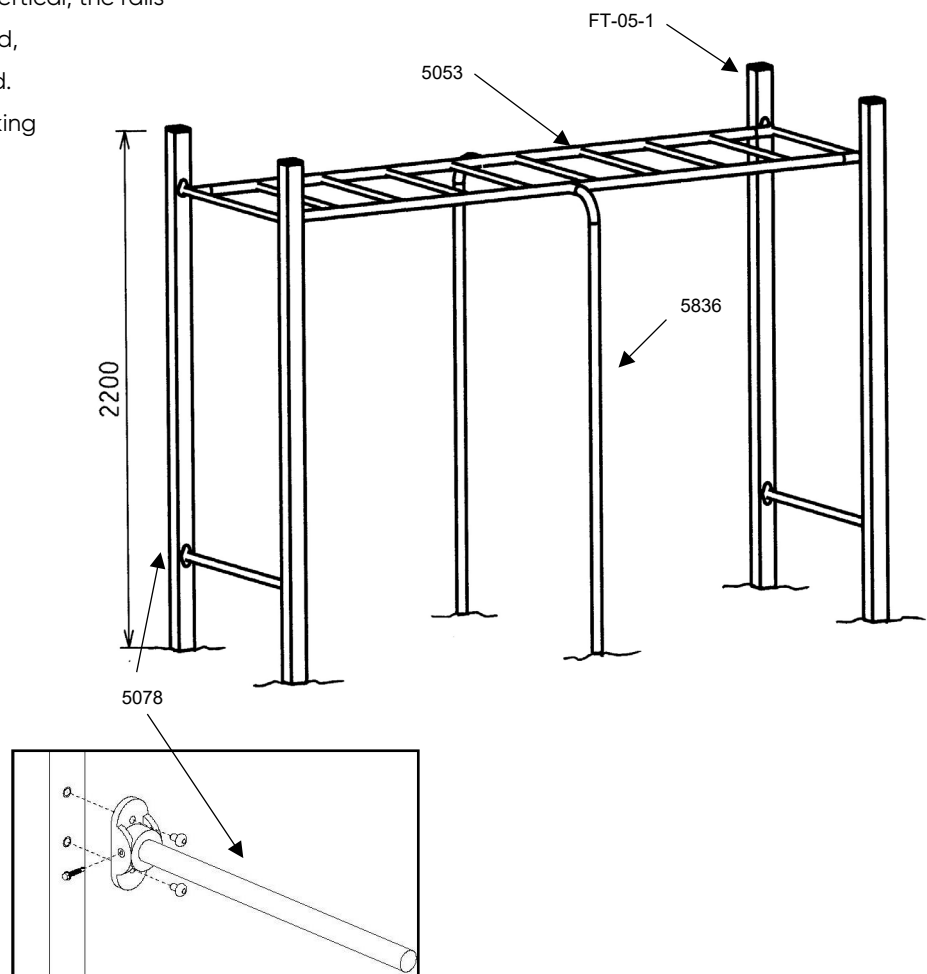
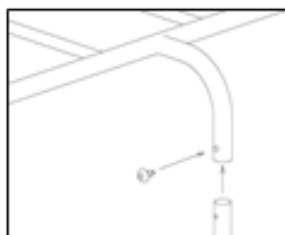

FT06 – Obstacle Frame

Using the 1650mm length rails (5576 or 5575) as a guide to determine the distance between uprights, dig holes for the uprights. After placing the uprights in the holes and ensuring that their depth is correct (so that the height of the upright which extends above the finished ground level is as indicated in the drawing), attach the flanges to the rails and fasten the rails to the uprights. After ensuring that the uprights are vertical, the rails horizontal and the bolts are tightened, concrete the uprights into the ground. Fill the top of the holes with soil, packing firmly.

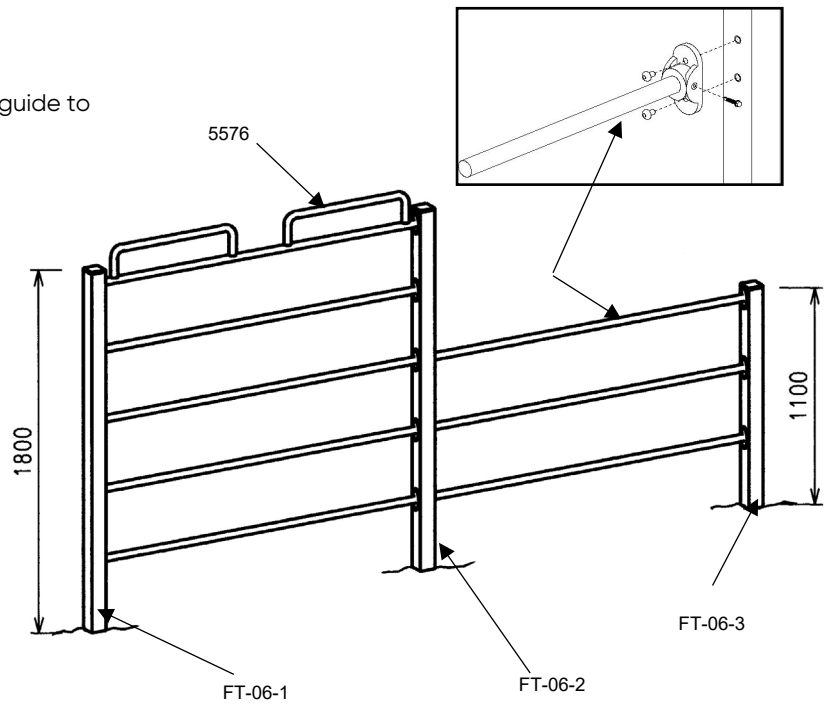

FT07 – Sit Up Board

The Sit-Up Board comes in 3 versions, with the angle of the boards being set at either 10, 15 or 20 degrees.

Assemble the Sit Up Board completely (before digging any holes in the ground), fastening the boards (6213) to the frames using 20mm tri-lobe bolts. Use the completed item to mark the location for the holes in the ground. The depth of the holes should allow for the lower end of the Sit Up Board to sit approximately 100mm above the finished ground level.

After ensuring that the bolts are tightened, lower the legs on the Sit Up Rack into the holes. Make sure that the frames are vertical then concrete the legs into the ground. Fill the top of the holes with soil, packing firmly.

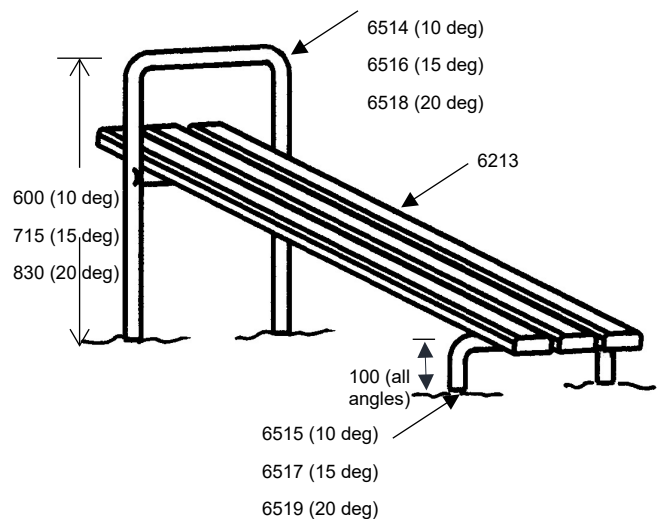

FT08 – Chain Net & Frame

Using the 1650mm length rails (FT-08-2 or 5575) as a guide to determine the distance between uprights, dig holes for the uprights. After placing the uprights in the holes and ensuring that their depth is correct (so that the height of the upright which extends above the finished ground level is as indicated in the drawing), attach the flanges to the rails and fasten the rails to the uprights.

Attach the top chains (FT-08-4) to the chain housings on the top rail (FT-08-2) and the bottom chains to the anchor (FT-08-3) using 8mm 'S' hooks. Ensure the 'S' hooks are fully closed using vice-grips.

Dig a trench for the anchor (FT-08-3) allowing for the chain to be on approximately a 45-degree angle with the top of the anchor being at least 300mm below the finished ground level.

After ensuring that the uprights are vertical, the rails horizontal and the bolts are tightened, concrete the uprights into the ground. Fill the top of the holes with soil, packing firmly.

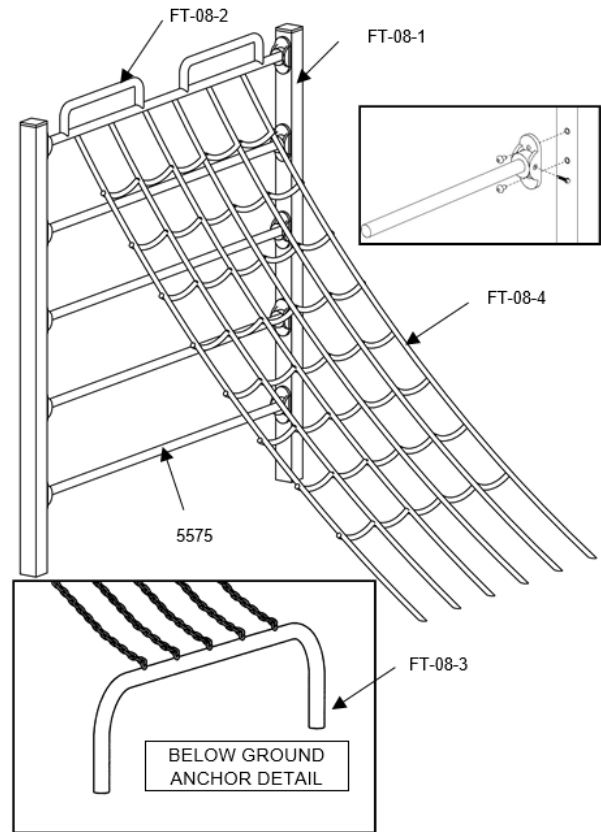

FT09 – Parallel Bars

Assemble the parallel bars on the ground (before digging any holes), inserting the legs (FT-09-2) into tapping bolts. Assemble the parallel bars on the ground (before digging any the top bars (FT-09-1) and fastening with 'tap tight' (self-bolts.

Use the legs to mark the correct position then dig the holes in the ground, ensuring that their depth is correct (so that the height of the top of the Parallel Bars is 1200mm above the finished ground level as indicated in the drawing.) The two Parallel bars should be positioned between 500mm and 600mm apart. After ensuring that the legs are vertical, the top rails horizontal and the bolts are tightened, concrete the legs into the ground. Fill the top of the holes with soil, packing firmly.

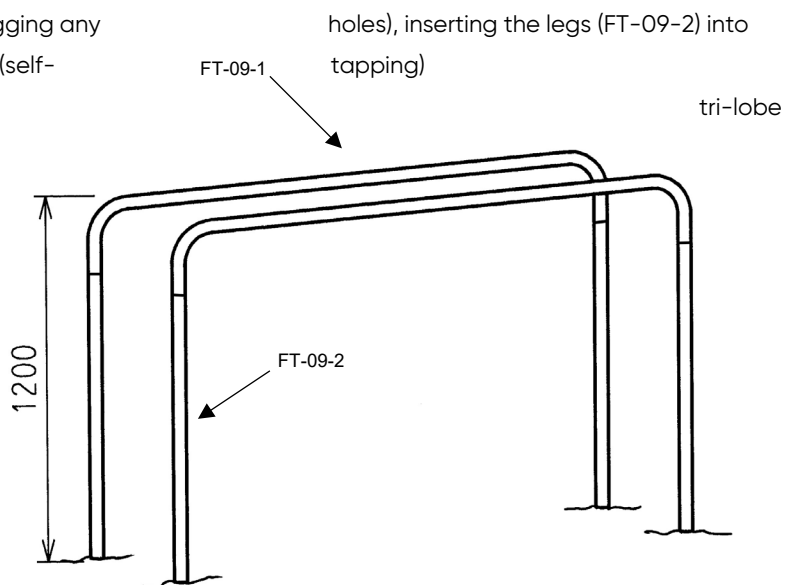

FT10 – Hurdles

Assemble the hurdles on the ground (before digging any holes), connecting the top beams (FT-10-1) to the uprights (FT-10-2) using 140mm cup head bolts and cap nuts.

Use the legs to mark the correct position then dig the holes in the ground, ensuring that their depth is correct (so that the height of the top beams are 500mm above the finished ground level as indicated in the drawing.) Each hurdle should be set at a uniform distance of at least 3 metres apart.

After ensuring that the legs are vertical, the top beams horizontal and the bolts are tightened, concrete the uprights into the ground. Fill the top of the holes with soil, packing firmly.

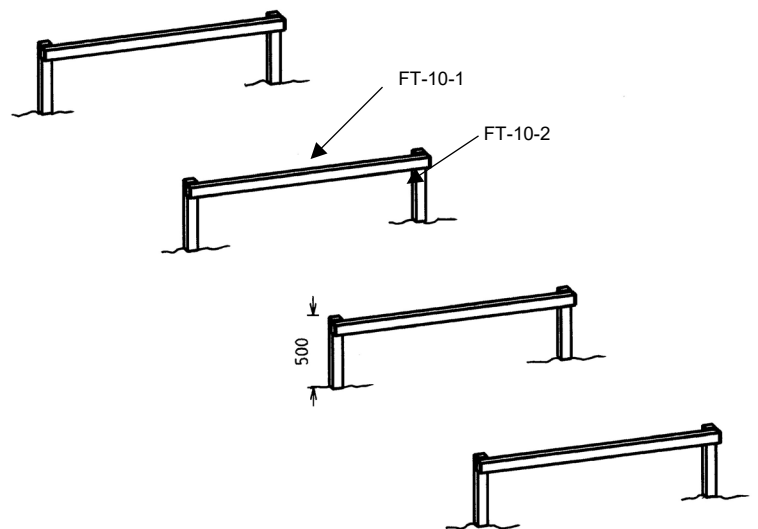

FT11a – Balance Walkers 'A'

Lay the top beams (FT-11A-1, 2 & 3) on the ground with each beam running at 90 degrees from the end of the last. Determine the position of the uprights by locating the holes in the top beams and dig the holes in the ground.

After placing the uprights in the holes and ensuring that their depth is correct (so that the height of the upright which extends above the finished ground level is as indicated in the drawing), fasten the top beams to the uprights using a 10x130 ST Stud and 2x ST 10x28 Cap Nuts. After ensuring that the legs are vertical, the top beams horizontal and the bolts are tightened, concrete the uprights into the ground. Fill the top of the holes with soil, packing firmly.

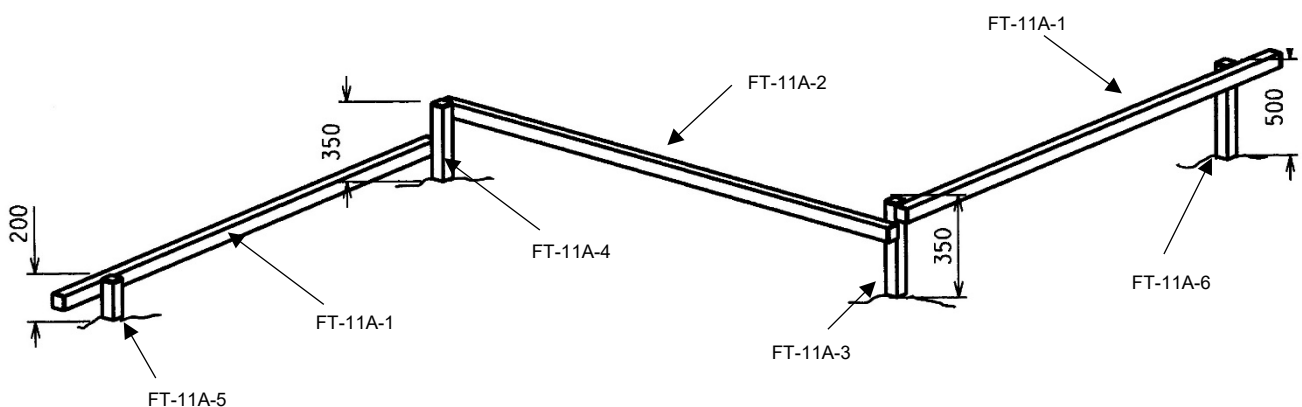

FT11b – Balance Walkers 'B'

Install these items in the same way as 'Hurdles' (above) except that each beam is free standing. Two of the balance beams should be set at 300mm above finished ground level, two at 500mm, and the last will incline from 300mm to 500mm.

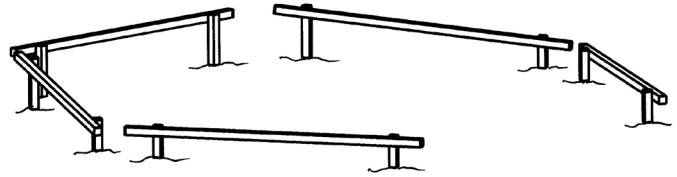

FT12 – Swinging Balance Beam

Using the handrails (5254) and the 'end frame joiners' (5599) as a guide to determine the distance between uprights, dig holes for the uprights. After placing the uprights in the holes and ensuring that their depth is correct (so that the height of the upright extends 1400mm above the finished ground level as indicated in the drawing), attach the flanges to the rails and fasten the rails to the uprights. Fasten the 'end frame joiners' to the uprights using 17mm tri-lobe bolts. After ensuring that the uprights are vertical, the rails horizontal and the bolts are tightened, concrete the uprights into the ground. Fill the top of the holes with soil, packing firmly.

Connect the balance beam to the chains and the end brackets using 8mm 'S' hooks. Ensure the 'S' hooks are fully closed using vice-grips. Attach the brackets to the end frame joiner using stainless steel cap nuts and 30mm cup head bolts.

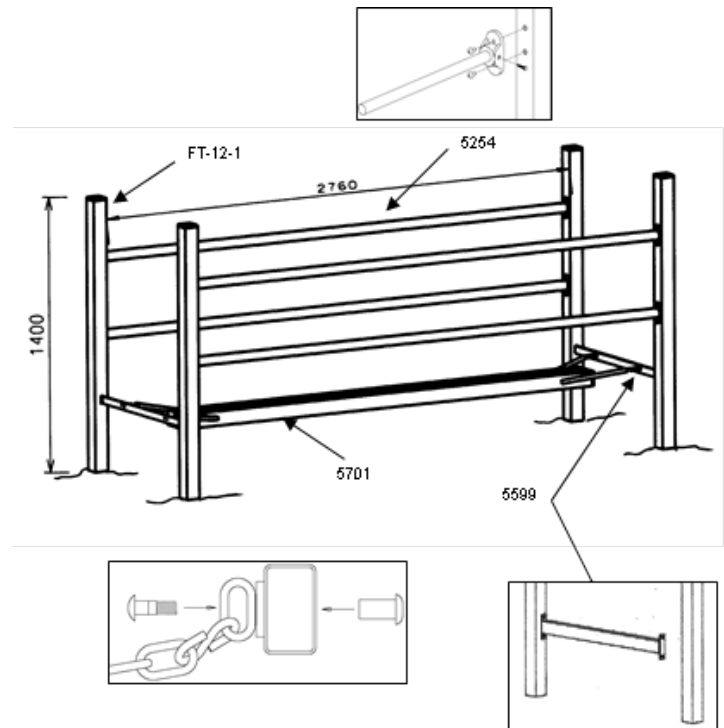

FT13 – Step Up

Assemble the Step Up on the ground (before digging any holes), connecting the top beam (FT-13-2) to the uprights (FT-13-1) using 140mm cup head bolts and cap nuts.

Use the legs to mark the correct position then dig the holes in the ground, ensuring that their depth is correct (so that the height of the top beam is 300mm above the finished ground level as indicated in the drawing.) After ensuring that the legs are vertical, the top beam horizontal and the bolts are tightened, concrete the uprights into the ground. Fill the top of the holes with soil, packing firmly.

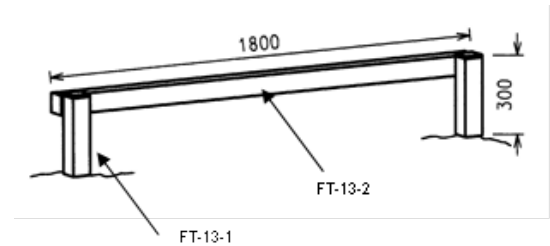

FT14 – Roman Triangles

Using the Roman Triangles (5073) as a guide to determine the distance between uprights, dig holes for the 4 uprights. Place the uprights in the holes and ensuring that their depth is correct (so that the height of the upright which extends above the finished ground level is as indicated in the drawing).

Attach the flanges to the Roman Triangles, lift them into place and fasten to the uprights. Attach flanges to the rungs (5078) and fasten to the uprights. After ensuring that the uprights are vertical, the top bar horizontal and the bolts are tightened, concrete the uprights into the ground. Fill the top of the holes with soil, packing firmly.

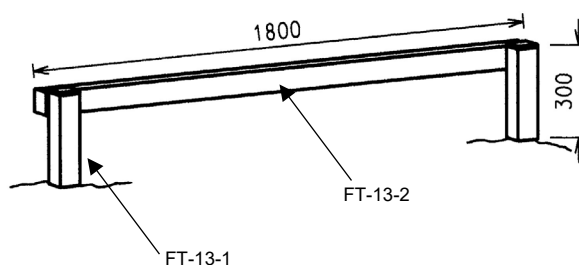
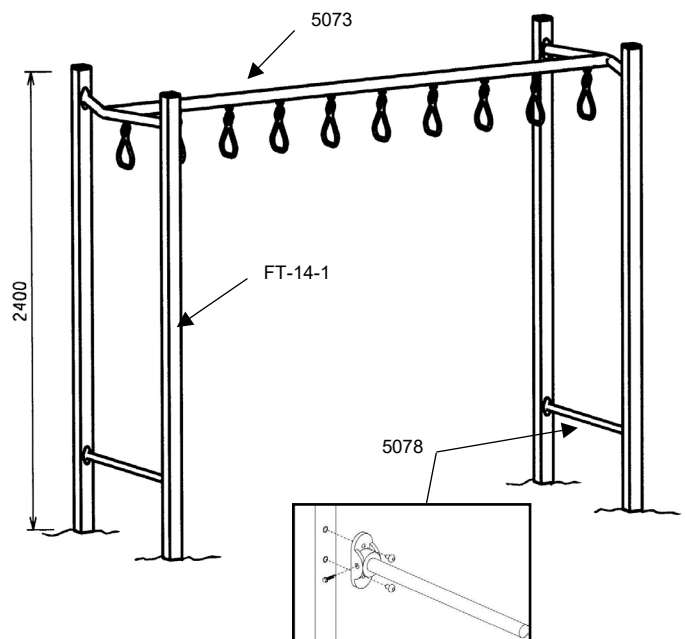

FT15 – Fireman’s Pole

The frame is best assembled before installation. Assemble the frame while laying on the ground then roll into the upright position. The uprights (6112) are fastened to the top bar (FT-15-1) using 25mm tri-lobe bolts. The tie bars (5896) are fastened to the uprights using a 130mm threaded stud with stainless steel cap nuts on both ends. Use the frame in its upright position to determine the correct hole position and dig the holes. Lower the frame into the holes, ensuring that the top bar is level and at the correct height (2.8m above the finished surface level). After ensuring that all bolts are tightened, concrete the uprights into the ground. Fill the top of the holes with soil, packing firmly.

Dig another hole for each fireman’s pole to a depth that allows them to hang straight down. Attach the top of the fireman’s poles to the top beam using 8mm ‘S’ hooks. Ensure the ‘S’ hooks are fully closed using vice-grips.

Concrete the chains at the base of the poles into the ground so that they hang virtually straight

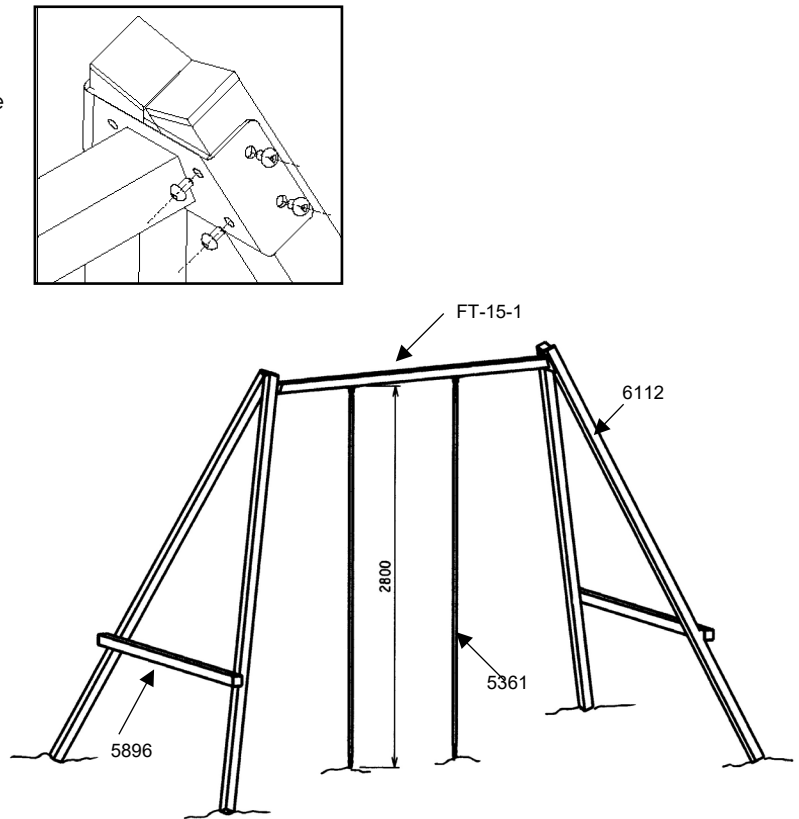

FT16 – Roll Over Bar

Assemble the Roll Over Bar on the ground (before digging any holes), inserting the legs (6016) into the top bar (FT-16-1) and fastening with ‘tap tight’ tri-lobe bolts.

Use the legs to mark the correct position then dig the holes in the ground, ensuring that their depth is correct (so that the height of the top of the Roll Over Bar is 900mm above the finished ground level as indicated in the drawing.) After ensuring that the legs are vertical, the top rail horizontal and the bolts are tightened, concrete the legs into the ground. Fill the top of the holes with soil, packing firmly.

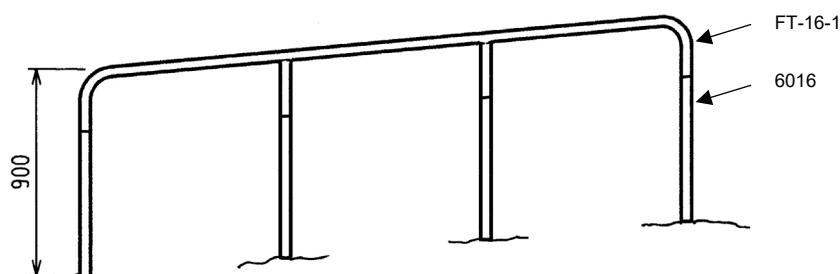

FT17 – Achilles Stretch

Dig a hole in the ground, ensuring that the depth is correct (so that the height of the top of the post is 1800mm above the finished ground level as indicated in the drawing.) After ensuring that the post is vertical concrete the legs into the ground. Fill the top of the holes with soil, packing firmly.

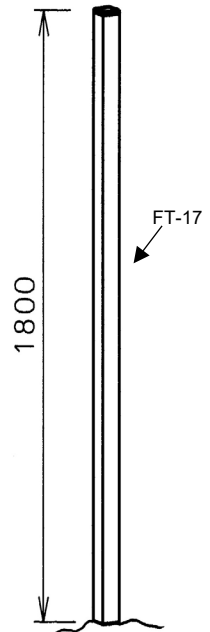

FT18 – Push Up Bars

Using the 1200mm length push up rails (5274) as a guide to determine the distance between uprights, dig holes for the uprights. After placing the uprights in the holes and ensuring that their depth is correct (so that the height of the upright which extends above the finished ground level is as indicated in the drawing), attach the flanges to the rails and fasten the rails to the uprights. After ensuring that the uprights are vertical, the rails horizontal and the bolts are tightened, concrete the uprights into the ground. Fill the top of the holes with soil, packing firmly.

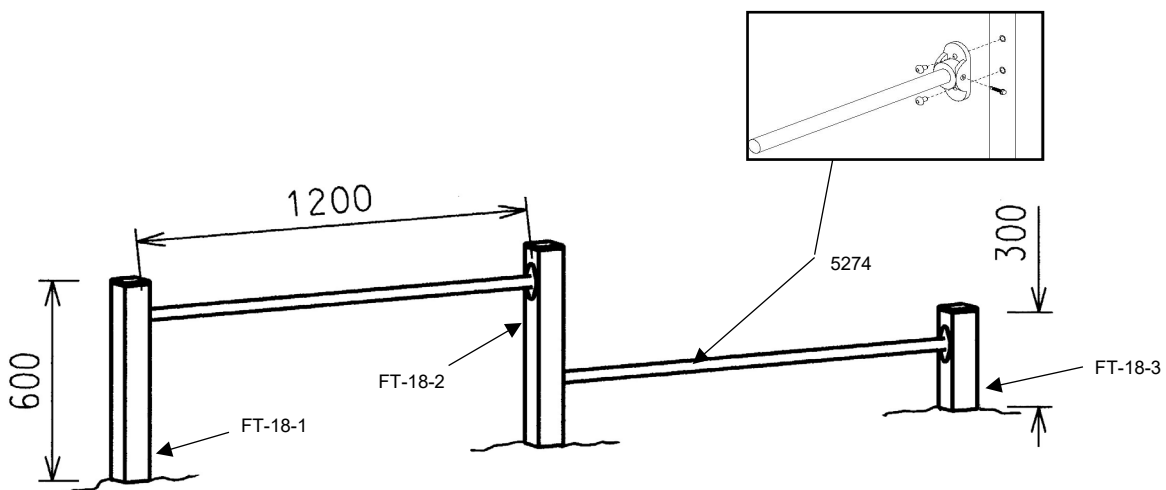

FT19 – Vault Bar

Assemble the Vault Bar on the ground (before digging any holes), inserting the leg (FT-09-2) into the top bar (FT-19-1) and fastening with a ‘tap tight’ tri-lobe.

Use the legs to mark the correct position then dig the holes in the ground, ensuring that their depth is correct (so that the height of the top of the Vault

Bars is 1200mm above the finished ground level as indicated in the drawing.)

After ensuring that the legs are vertical and the bolt is tightened, concrete the legs into the ground. Fill the top of the holes with soil, packing firmly.

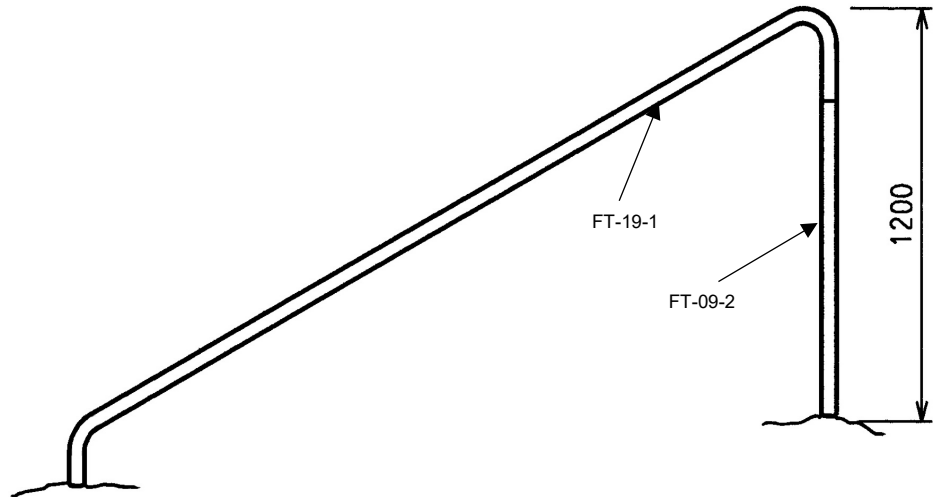

FT20 – Leg Lift Bar

Dig a hole in the ground, ensuring that the depth is correct (so that the height of the top of the post is 2200mm above the finished ground level as indicated in the drawing.) After ensuring that the post is vertical concrete the legs into the ground. Fill the top of the holes with soil, packing firmly.

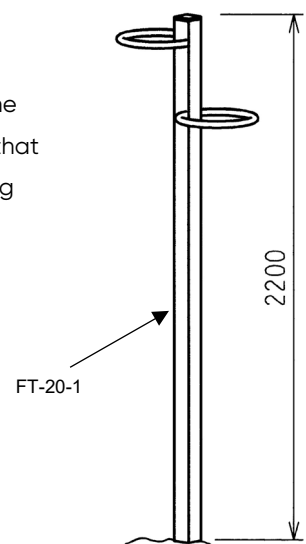

FT23 – Burmese Bridge

Using the handrails (5011) and the 'end frame joiners' (5599) as a guide to determine the distance between uprights, dig holes for the uprights. After placing the uprights in the holes and ensuring that their depth is correct (so that the height of the upright extends 1400mm above the finished ground level as indicated in the drawing), attach the flanges to the rails and fasten the rails to the uprights. Fasten the 'end frame joiners' using 17mm tri-lobe bolts. After ensuring that the uprights are vertical, the rails horizontal and the bolts are tightened, concrete the uprights into the ground. Fill the top of the holes with soil, packing firmly.

Attach each bracket (S5191) to the end frame joiners using stainless steel cap nuts and 30mm cup head bolts. Attach the chains (5883) to the brackets and the handrails using 8mm 'S' hooks. Ensure the 'S' hooks are fully closed using vice-grips.

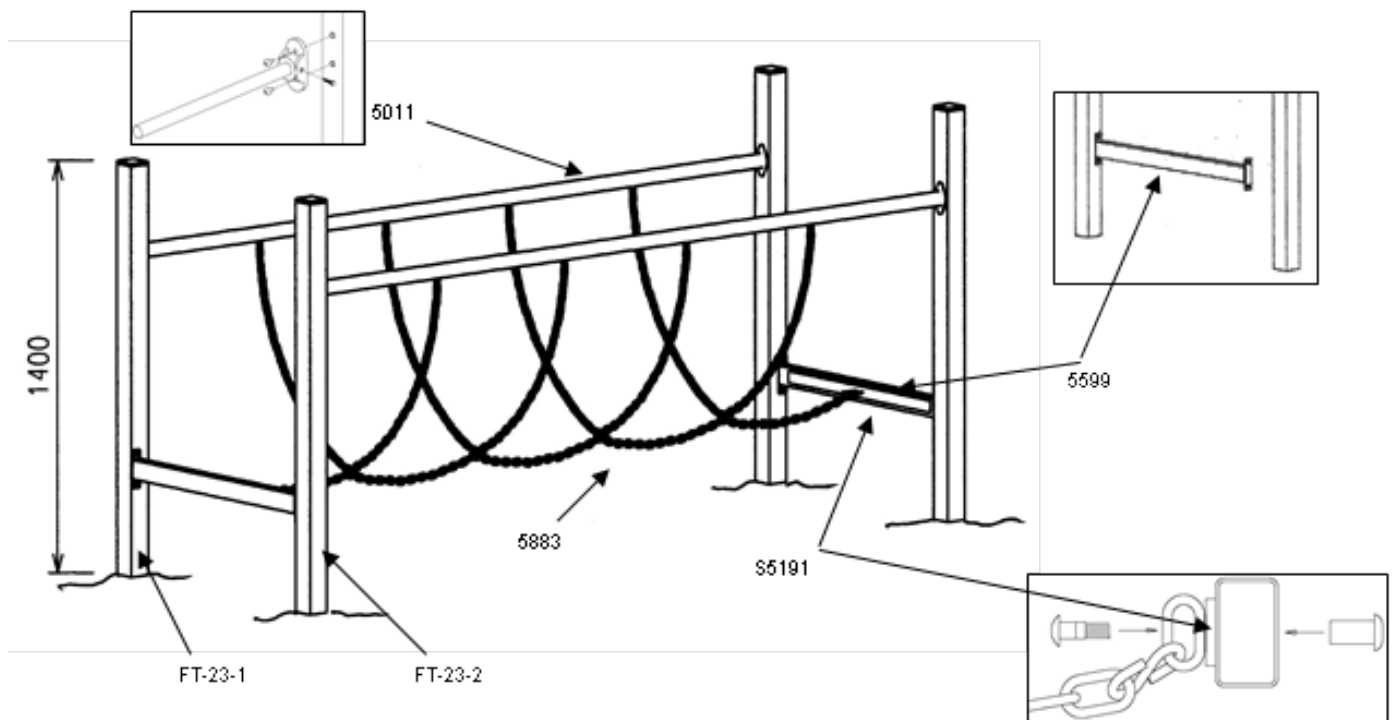

FT24 – Challenge Rail

Using the Challenge Rail (6190) as a guide to determine the distance between uprights, dig holes for the 4 uprights. Place the uprights in the holes and ensuring that their depth is correct (so that the height of the upright which extends above the finished ground level is as indicated in the drawing).

Attach the flanges to the Challenge Rail, lift them into place and fasten to the uprights. Attach flanges to the rungs (5078) and fasten to the uprights. After ensuring that the uprights are vertical, the top bar horizontal and the bolts are tightened, concrete the uprights into the ground. Fill the top of the holes with soil, packing firmly.

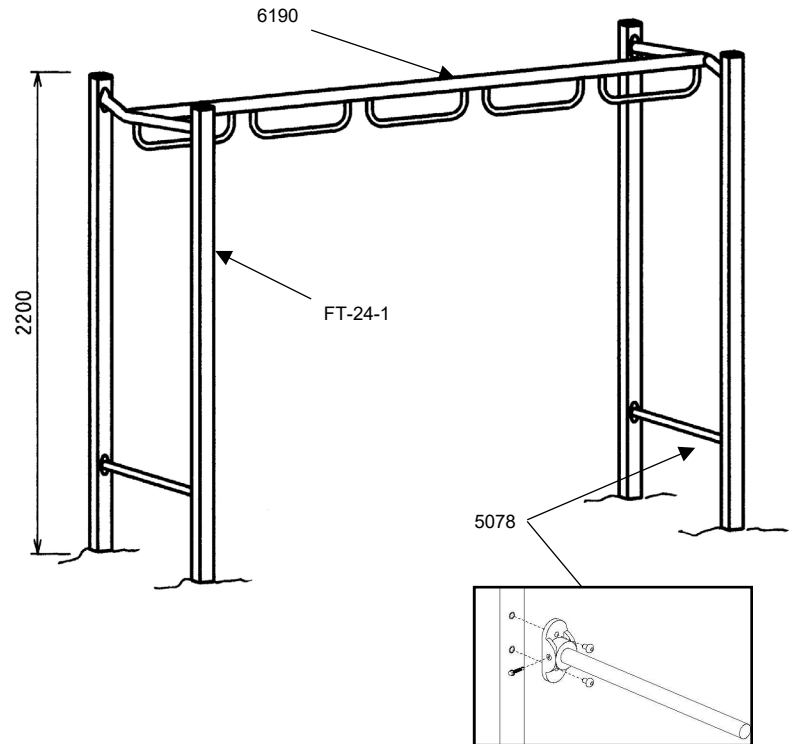

FT25 – Arched Roman Triangles

Using the Arched Roman Triangles (5231) as a guide to determine the distance between uprights, dig holes for the 4 uprights. Place the uprights in the holes and ensuring that their depth is correct (so that the height of the upright which extends above the finished ground level is as indicated in the drawing).

Attach the flanges to the Arched Roman Triangles, lift them into place and fasten to the uprights.

After ensuring that the uprights are vertical, the top bar horizontal and the bolts are tightened, concrete the uprights into the ground. Fill the top of the holes with soil, packing firmly.

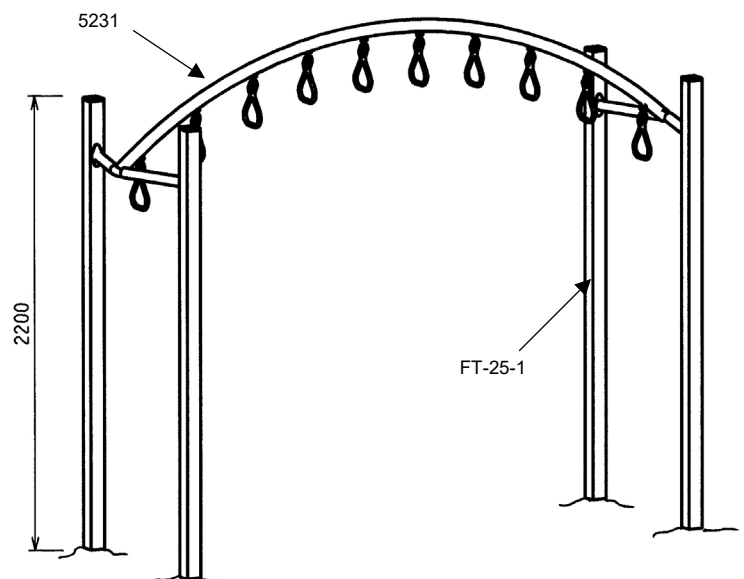

FT26 – Hang ‘n’ Glide

Using the Hang ‘n’ Glide top bar (5045) as a guide to determine the distance between uprights, dig holes for the 4 long uprights. Place the uprights in the holes and ensuring that their depth is correct (so that the height of the upright which extends above the finished ground level is as indicated in the drawing).

Attach the flanges to the Hang ‘n’ Glide, lift into place and fasten to the uprights. Using the platforms (S6525) as a guide to determine the hole position, dig holes for the short uprights. Place the uprights in the holes and ensuring that their depth is correct (so that the height of the upright which extends above the finished ground level is 400mm as indicated in the drawing).

Fasten each corner of the platform to the uprights using 17mm tri-lobe bolts, bolting from the underside of the platform into the upright. (While holes are drilled for 2 tri-lobes on each corner the angle may make fastening the second difficult. One tri-lobe in each corner will be sufficient.)

After ensuring that the platforms are level, the uprights are vertical, the top

bar horizontal and the bolts are tightened, concrete the uprights into the ground. Fill the top of the holes with soil, packing firmly.

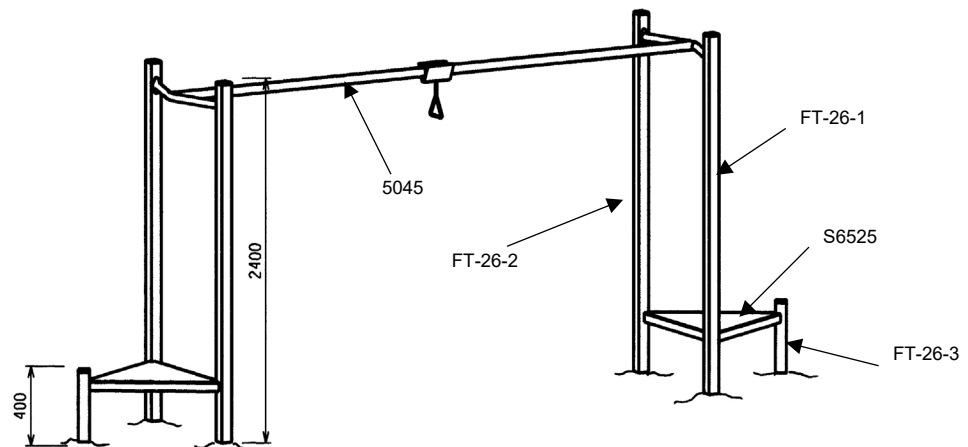

FT28 – Vertical Rung Climber

Using the top bar (6660) as a guide to determine the distance between uprights, dig holes for the uprights. Attach the bracket at the top of the rung climber (6630) to the top bar using stainless steel 70mm cup head bolts and cap nuts. Lift the top bar into place and connect to the uprights using 17mm tri-lobe bolts. Place the uprights in the holes, ensuring that their depth is correct (so that the height of the upright which extends above the finished ground level is as indicated in the drawing). Dig a trench between the two uprights for the chain. Place the lower end of the rung climber into the trench, making sure the chains are taut. After ensuring that the bolts are tightened and the uprights vertical concrete the uprights and the lower end of the rung climber into the ground. Fill the top of the holes with soil, packing firmly.

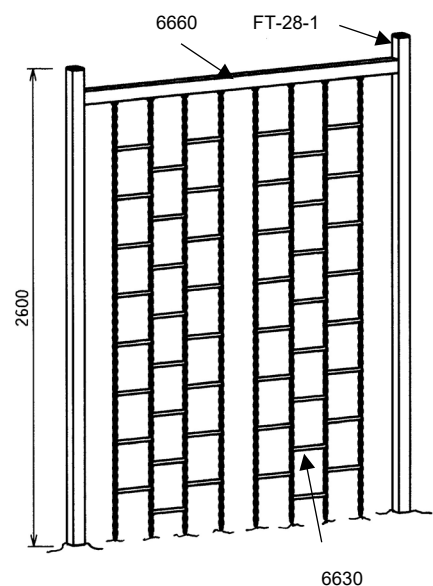

FT29 – TreadMill

Using the 870mm length rung (5078) as a guide to determine the distance between uprights, dig holes for the uprights. Dig the holes with a trench between them to allow for the rung.

Assemble the treadmill before inserting it into the hole.

Attach the flanges to the rung and fasten to the uprights (below-finished ground level).

Attach the treadmill (6010) to the uprights using 17mm tri-lobe bolts. Attach the handgrips (7095) above the treadmill using 20mm tri-lobes.

Insert the uprights into the hole into the ground, ensuring that their depth is correct. (The height of the upright which extends above the finished ground level is 1400mm as indicated in the drawing and the top of the treadmill should be approximately 400mm above the finished ground surface.)

After ensuring that the bolts are tightened and the uprights vertical, concrete the uprights into the ground. Fill the top of the holes with soil, packing firmly.

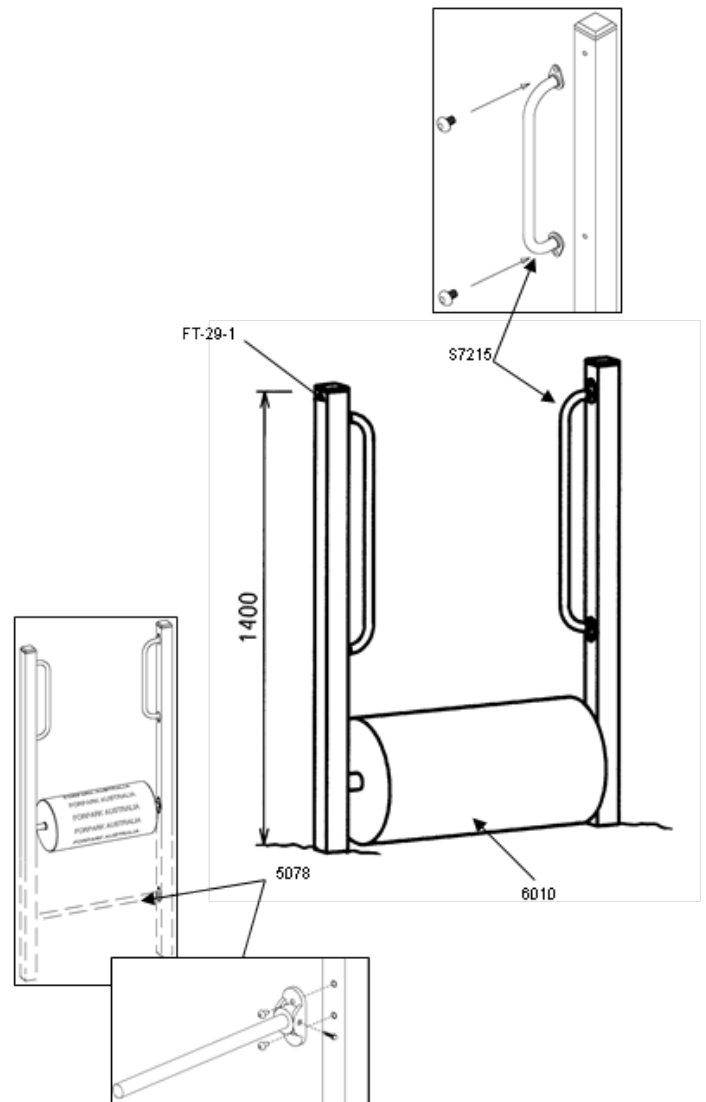

FT30 – Combat & Rung Climber

Using the 870mm length, 'end frame joiner' (5599), as a guide to determine the distance between uprights and dig holes for the uprights. Attach the 'end frame joiner' to the uprights using 17mm tri-lobe bolts. Attach the flanges to the top rail (5848) and fasten to the uprights and the handgrips (7095) using 20mm tri-lobe bolts.

Insert the uprights into the holes, ensuring that their depth is correct (so that the height of the upright which extends above the finished ground level is as indicated in the drawing).

Dig a trench on either side of the uprights, wide enough for the base of the combat climber and the rung climber. Use the combat legs (6210) to determine the distance out on one side and allow approximately 1.0 -1.2m to the other side for the rung climber.

Attach the top bracket of the rung climber (6600) and the combat legs to opposing sides of the end frame joiner using 17mm tri-lobe bolts. The base of the rung climber should be approximately 500mm below the finished ground surface and fixed so that the chain is fairly taught when pulled out.

Attach the boards (7163) and the 'combat tie bar' (6212) to the frame using a cap nut through the top of the board and a 40mm tri-lobe through the underside of the frame. Before the bolts are inserted you should apply a small amount of 'Loctite' to the thread. Using 8mm 'S' hooks, attach one end of the chain to the base of the frame and the other end to the handrail. Ensure the 'S' hooks are closed fully using vice-grips.

After ensuring that the bolts are tightened and the uprights vertical, concrete the uprights, combat joiner and rung climber into the ground. Fill the top of the holes with soil, packing firmly. Attach the handgrips (7095) above the treadmill using 'tap tight' tri-lobes.

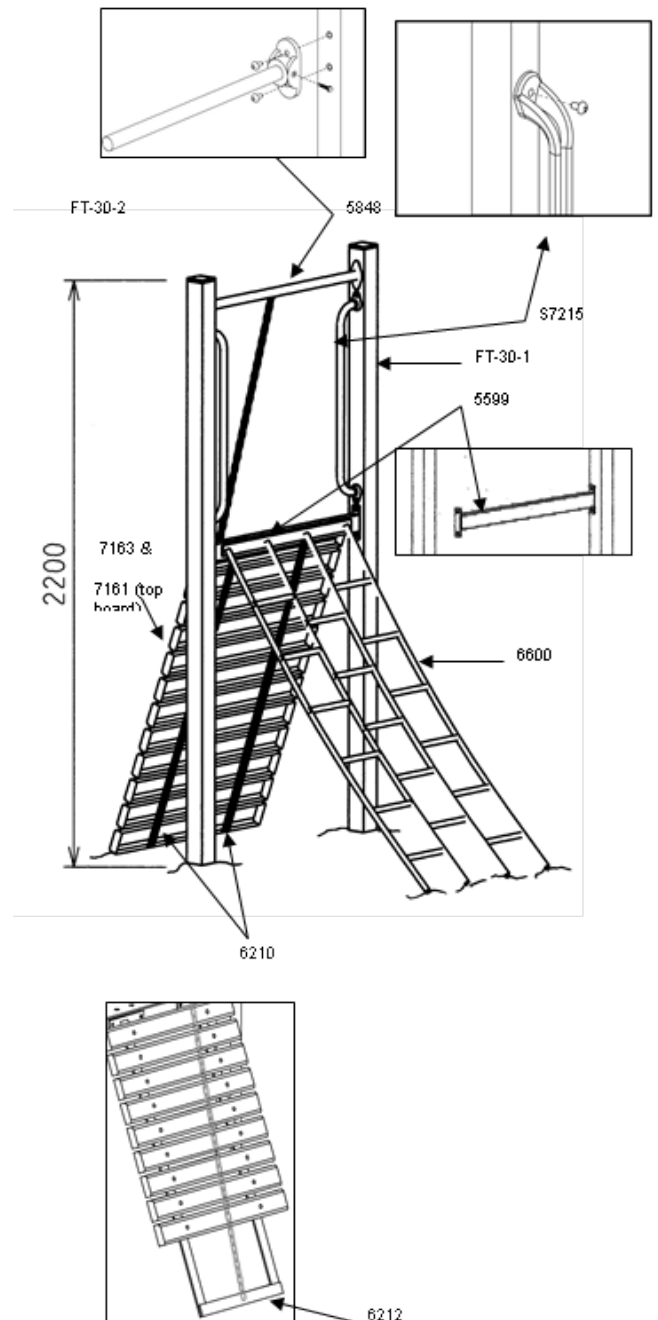

FT31 – Commando Climber

Using the 870mm length, 'end frame joiner' (5599), as a guide to determine the distance between uprights and dig holes for the uprights. Attach the 'end frame joiner' to the uprights using 17mm tri-lobe bolts. Attach the flanges to the top rail (5848) and fasten to the uprights and the handgrips (7095) using 20mm tri-lobe bolts.

Insert the uprights into the holes, ensuring that their depth is correct (so that the height of the upright which extends above the finished ground level is as indicated in the drawing).

Dig a trench on one side of the uprights, wide enough for the base of the combat climber. Use the combat legs (6211) to determine the distance out.

Attach the combat legs to one side of the end frame joiner using 40mm tri-lobes and 'T' nuts with the 'T' nut being on the same side as the combat climber.

Attach the boards (7163) and the 'combat tie bar' (6212) to the frame using a cap nut through the top of the board and a 40mm tri-lobe through the underside of the frame. Before the bolts are inserted you should apply a small amount of 'Loctite' to the thread. Using 8mm 'S' hooks, attach one end of the chain to the base of the frame and the other end to the handrail. Ensure the 'S' hooks are closed fully using vice-grips.

Position the rock-climbing wall (S6963) in place between the two uprights with the top just below the bottom of the 'end frame joiner'. Using tri-lobes attach the sides of the wall to the uprights entering from underneath the platform. Start at the top and work down.

After ensuring that the bolts are tightened and the uprights vertical, concrete the uprights and the combat joiner into the ground. Fill the top of the holes with soil, packing firmly.

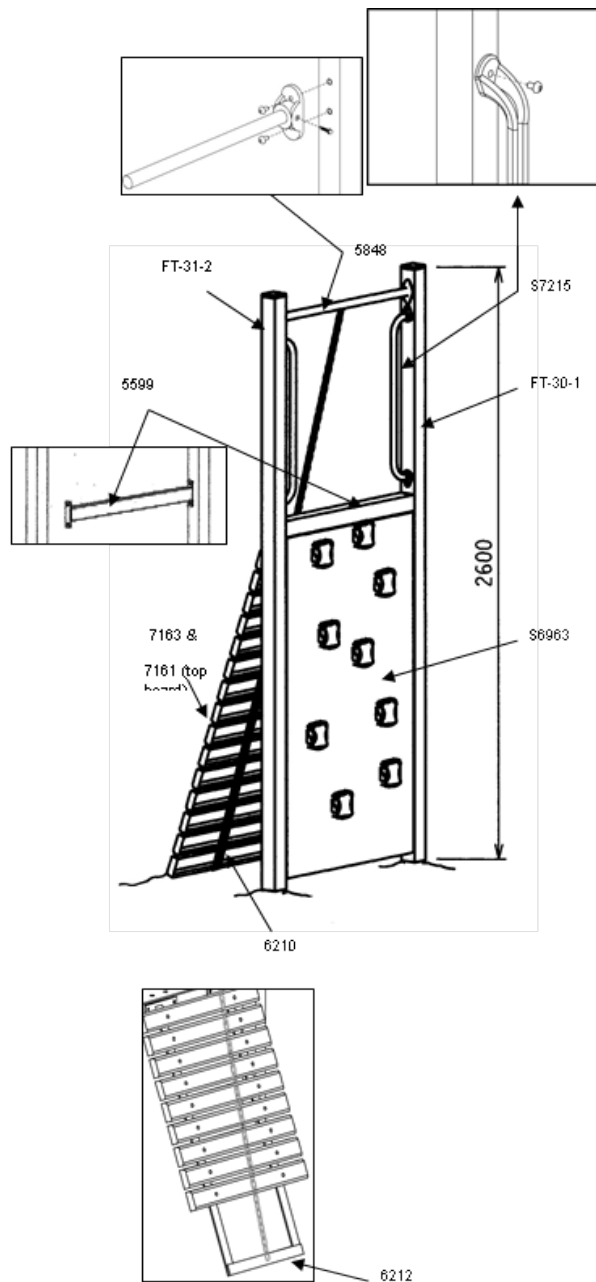

FT32 – Pommel Walker

Using the top bar (6606) as a guide to determine the distance between uprights, dig holes for the 4 uprights. Place the uprights in the holes and ensuring that their depth is correct (so that the height of the upright which extends above the finished ground level is as indicated in the drawing).

Attach the suspended chains (6885) to the top bar using 8mm 'S' hooks (ensure that the 'S' hooks are fully closed using vice-grips). Attach the flanges to the Pommel Walker, lift into place and fasten to the uprights. Dig a hole directly below each suspended chain and pommel. Place the lower ends of each chain into the holes making sure they are taut.

To join the steps (6451), attach two 'L' brackets to each upright using 17mm tri-lobe bolts. Rest the step on top of the 'L' brackets and fasten from underneath using standard tri-lobes.

After ensuring that the uprights are vertical, the top bar horizontal and the bolts are tightened, concrete the uprights and the lower end of the chains into the ground. Fill the top of the holes with soil, packing firmly.

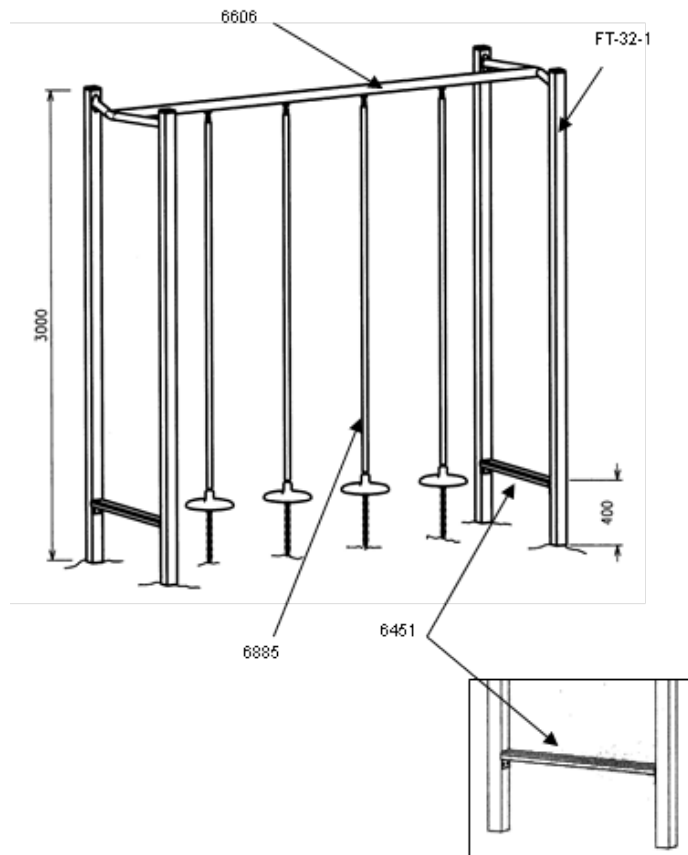

FT33 – Rock Wall & Pole

Using the platform (S5625) as a guide to determine the distance between uprights, dig holes for the 3 uprights. Place the uprights in the holes and ensuring that their depth is correct (so that the height of each upright that extends above the finished ground level is as indicated in the drawing).

Note: Two of the uprights will be square to each other while the third is on an angle. It is important to ensure that the two which sit squarely are on the side of the platform which will contain the rock climbing wall (S6962).

Fasten each corner of the platform to the uprights using 17mm tri-lobe bolts, bolting from the underside of the platform into the upright. (While holes are drilled for 2 tri-lobes on each corner the angle may make fastening the second difficult. One tri-lobe in each corner will be sufficient.)

Attach the rock climbing wall first to provide some stability to the structure. Position the rock climbing wall in place between the two uprights with the top just below the bottom of the platform. Using 17mm tri-lobe bolts attach the sides of the wall to the uprights entering from underneath the platform. Start at the top and work down.

Next, attach the safety panel (5542) to the structure. The top of the panel is connected to the uprights using 17mm tri-lobes. The bottom of the panel is fastened to the side of the platform using the same bolts as above.

Attach the flanges to the fire top (5763) and the fire top to the fire pole (5188) using a tap-tight (self-tapping) tri-lobe bolt. Lift the pole into its approximate place to determine the position of the hole in the ground. Dig the hole (approximately 600mm deep) and place the pole into position, attaching the fire top to the uprights using flanges. It is advisable to place a brick or a block of wood below the pole to provide additional stability. Attach the handgrips (7095) above the platform adjacent to the rock climbing wall and the fire pole using 25mm tri-lobe bolts.

After ensuring that all bolts are tightened, the uprights and fire pole vertical, and the platform level concrete the uprights and the fire pole into the ground. Fill the top of the holes with soil, packing firmly.

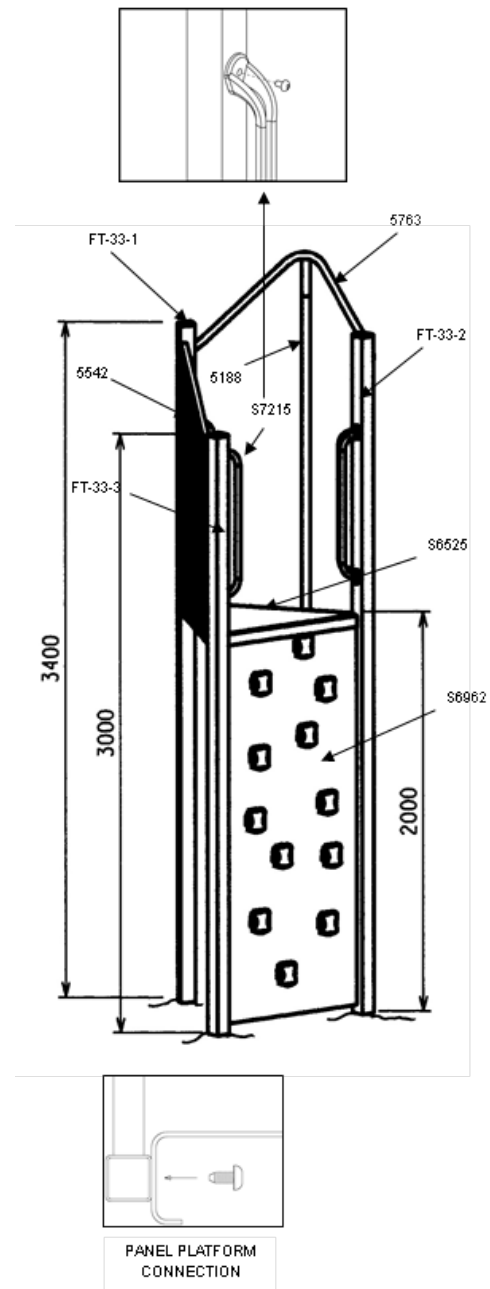

FT34 – Arched Monkey Bar

Using the Arched Monkey Bar (6261) as a guide to determine the distance between uprights, dig holes for the 4 uprights. Place the uprights in the holes and ensuring that their depth is correct (so that the height of the upright which extends above the finished ground level is as indicated in the drawing).

Attach the flanges to the Arched Monkey Bar, lift them into place and fasten to the uprights. Attach flanges to the rungs (5078) and fasten to the uprights.

After ensuring that the uprights are vertical, the top bar horizontal and the bolts are tightened, concrete the uprights into the ground. Fill the top of the holes with soil, packing firmly.

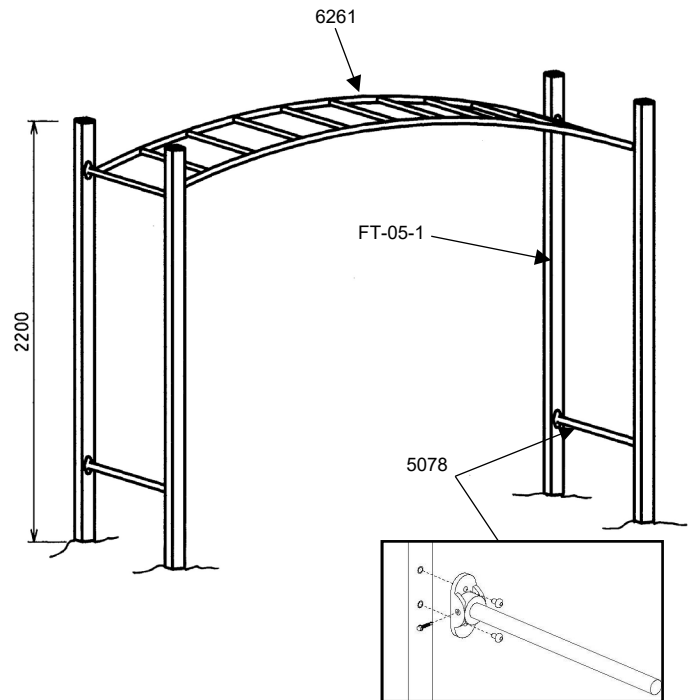

FT35 – Roman Monkey Bar

Using the Roman Monkey Bar (6261) as a guide to determine the distance between uprights, dig holes for the 4 uprights. Place the uprights in the holes and ensuring that their depth is correct (so that the height of the upright which extends above the finished ground level is as indicated in the drawing).

Attach the flanges to the Roman Monkey Bar, lift them into place and fasten to the uprights. Attach flanges to the rungs (5078) and fasten to the uprights.

After ensuring that the uprights are vertical, the top bar horizontal and the bolts are tightened, concrete the uprights into the ground. Fill the top of the holes with soil, packing firmly.

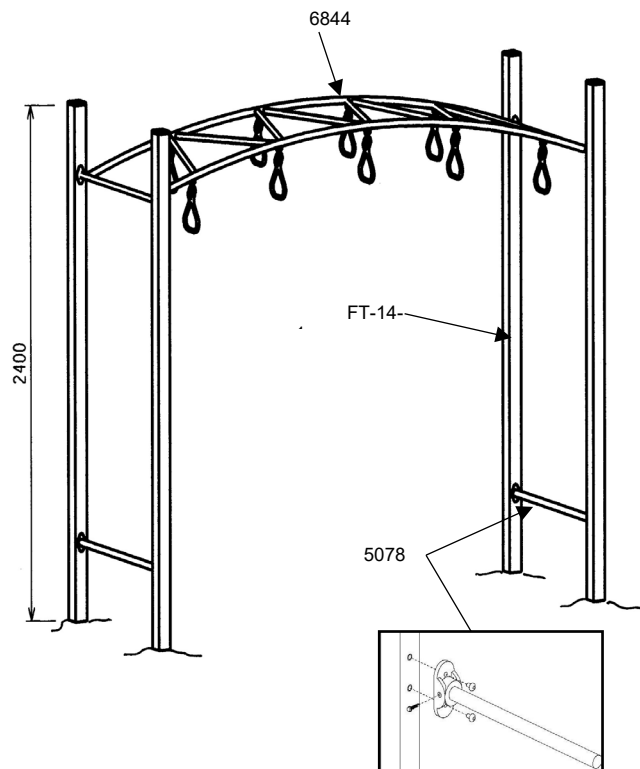

FT39 – Double Sided Rock Wall

The Rock Wall can either be completely assembled on the ground and lifted into place or it can be connected to the uprights once they are in the ground. Use the rock wall (7869) to determine the position of both upright holes. Dig the holes and insert the uprights (so that the height of the upright which extends above the finished ground level is as indicated in the drawing).

Attach the brackets (5228) to the rock wall using a 17mm tri-lobe bolt and a 10mm washer through the bracket and a T-nut and nylon washer through the reverse side of the wall.

Position the rock wall in place between the uprights and fasten using 17mm tri-lobe bolts. Attach the flanges to the top rail (5274) and fasten them to the uprights above the rock wall.

After ensuring that the bolts are tightened and the uprights vertical, concrete the uprights into the ground.

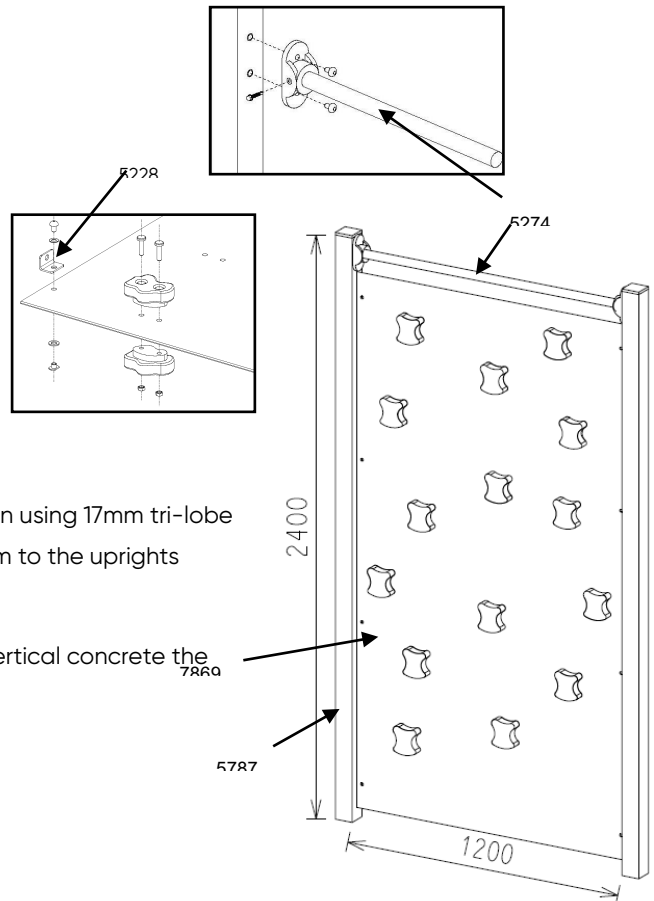

FT40 – Aerobic Stepper

Using the 870mm length steps (6451) as a guide to determine the distance between uprights and distance between steps, dig holes for the uprights. After placing the uprights in the holes and ensuring that their depth is correct as indicated in the drawing, fasten the steps to the uprights using 17mm tri-lobes and brackets (S528), 2 each side. After ensuring that the uprights are vertical, the steps horizontal and the bolts are tightened, concrete the uprights into the ground. Fill the top of the holes with soil, packing firmly.

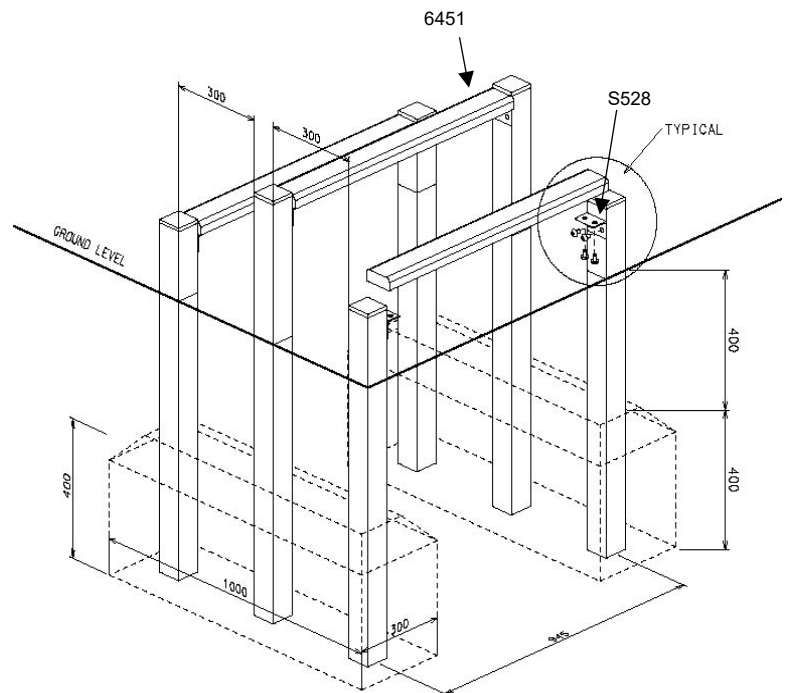

FT42 – Stretch Station

Using dimensions as a guide to determine the distance between uprights, dig holes for the 3 uprights. Insert the uprights (so that the height of the upright which extends above the finished ground level is as indicated in the drawing). To join the step, attach two 'L' brackets to each upright using 17mm tri-lobe bolts. Rest the step on top of the 'L' brackets and fasten from underneath using 17mm tri-lobes. Attach the handgrips to the uprights using 25mm tri-lobe bolts. Attach the flanges to the rails and fasten to the uprights. (Some of the flanges are angled to match the orientation of the uprights.)

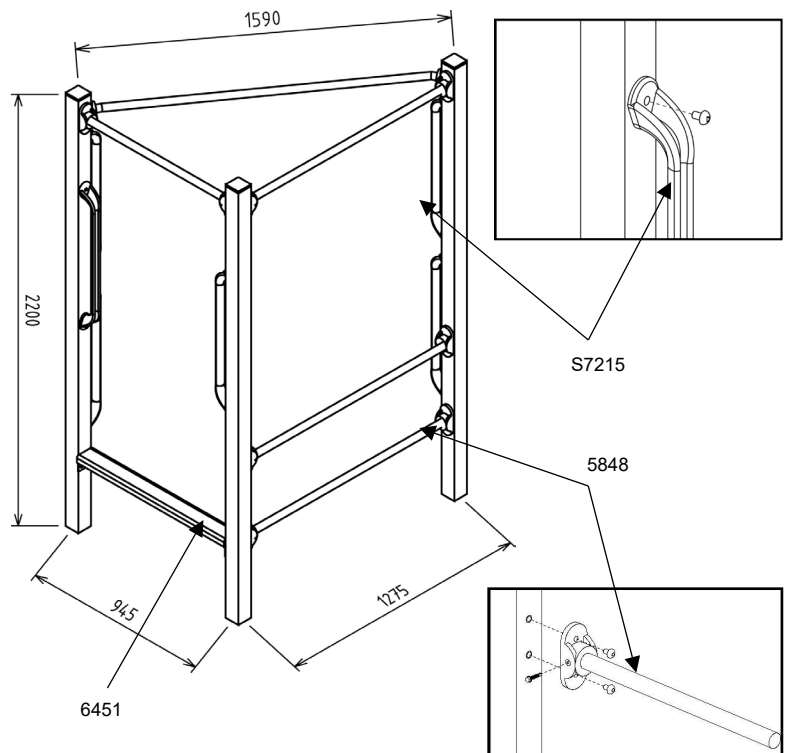

FT43 – FT Sign

Dig a hole in the ground, ensuring that the depth is correct (so that the height of the top of the post is 1000mm above the finished ground level as indicated in the drawing.) After ensuring that the post is vertical concrete the legs into the ground. Fill the top of the holes with soil, packing firmly.

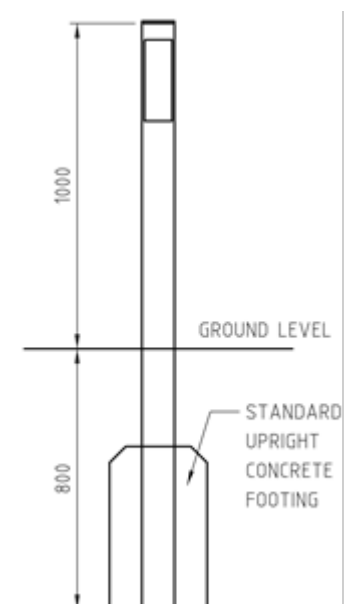

FT44 – Steppers

Fasten steppers to the uprights using 17mm tri-lobes. Dig holes for each upright. The Steppers can be arranged in varying configurations but the distance between each should be approximately 500mm from centre to centre. The heights from finished ground level to the top of each stepper should be 200mm, 300mm, 400mm, 500mm, 400mm, 300mm and 200mm respectively. After placing the uprights in the holes and ensuring that their depth is correct and that the uprights are vertical, concrete them into the ground. Fill the top of the holes with soil, packing firmly.

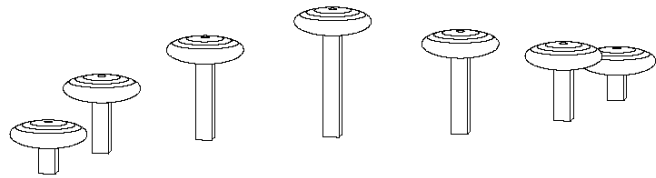

FT50 – Parallel Bars (Heavy)

Dig holes for the 4 uprights. Place the uprights in the holes and ensuring that their depth is correct (so that the height of the upright which extends above the finished ground level is as indicated in the drawing).

Attach bars into place and fasten to the uprights with 17mm tri-lobe bolts.

After ensuring that the uprights are vertical, the top bar horizontal and the bolts are tightened, concrete the uprights into the ground.

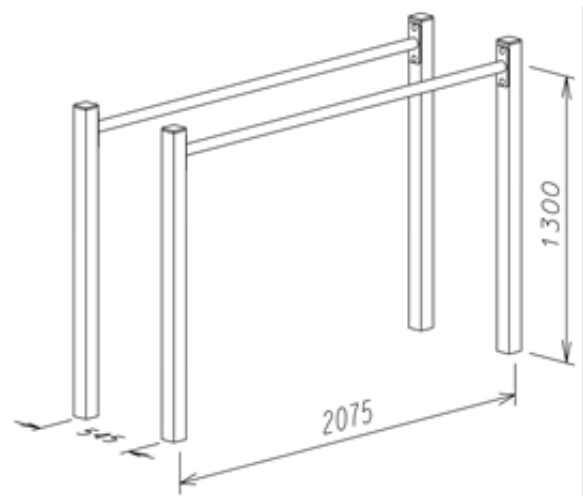

FT51 – Dip Bars

Dig 900x400 hole in ground 800 deep.

Join both bars to two frames with bolts Post Torx 10x20. Attach panels to bars using Cap Nuts with Studs in the middle.

Rise frame into the hole, keep vertical and concrete as shown.

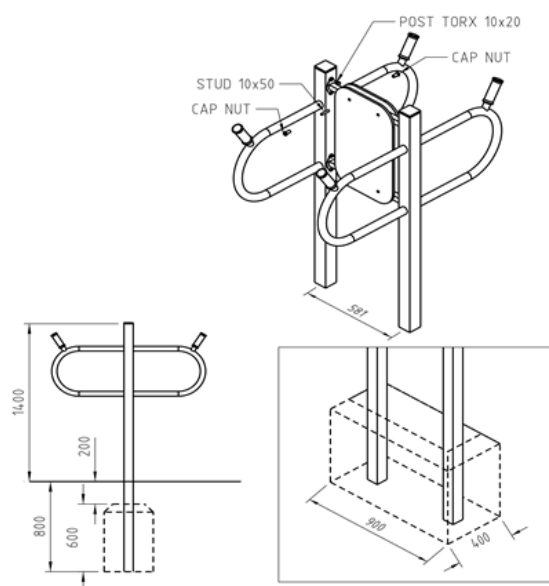

FT52 - Unders & Overs

Assemble the hurdles on the ground (before digging any holes), connecting the top beams to the uprights using 140mm cup head bolts and cap nuts.

Use the legs to mark the correct position then dig the holes in the ground, ensuring that their depth is correct (so that the height of the top beams are 875mm and 1075mm above the finished ground level as indicated in the drawing.) Each hurdle should be set at a uniform distance of at least 3 metres apart.

After ensuring that the legs are vertical, the top beams horizontal and the bolts are tightened, concrete the uprights into the ground. Fill the top of the holes with soil, packing firmly.

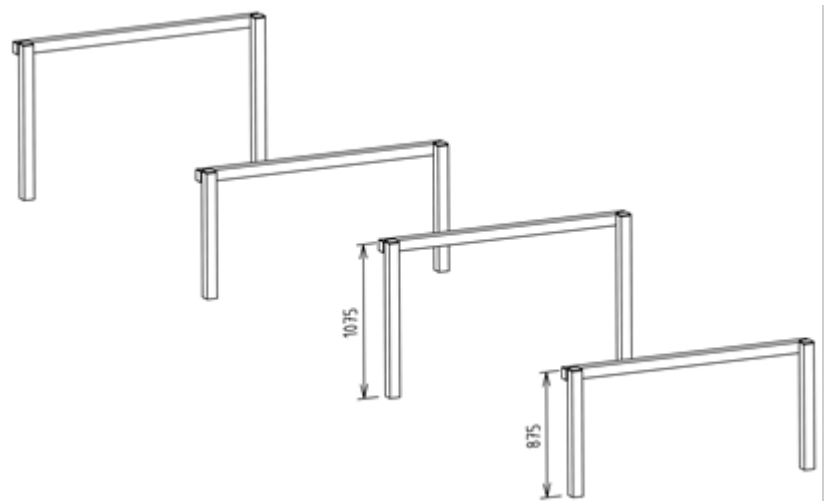

FT55 – Ninja Step

Fasten 3 legs to panel and rubber pad as shown with middle 2 holes leg. Arrange the number of steps and the distance as per customer plan and mark the ground holes. Dig 600x600 hole in ground, 600mm deep. After placing the legs in the holes and ensuring that are vertical and their depth is correct, concrete them into the ground.

