



Installation Manual - Elevate



Congratulations on selecting PlayCo equipment for your playground.

This manual provides you with easy-to-follow instructions that will enable you to install the equipment correctly. Installing your playground can be a simple and rewarding task and it is satisfying to be able to stand back when the job is finished and say “We did that!”

As a quality-assured company, our equipment complies with the following standards for play equipment as a minimum, to ensure the safety of your children.

- AS 4685:2021, Parts 1 – 6, Playground equipment (Safety requirements and test methods)
- AS 4422:2016 Playground surfacing – Specifications, requirements and test method
- AS 4685.0.2017 Playgrounds and playground equipment – Part 1: Development, slide installation, inspection, maintenance, and operation

You may be interested to know that PlayCo an Australian-owned company and that we are the largest in-house manufacturer of playground equipment in Australia.

We have been manufacturing playground equipment since 1979 and provide you with the benefit of the knowledge and experience that we have developed over these years.

This installation manual should be kept for future reference and to help you with your maintenance program. A recommended maintenance schedule is provided at the rear of this manual.

Good luck with your installation.

Contents

Prepare the site.....	1	Entrance Double Slide Panel	31
Equipment required for installation.....	1	Vertical Panel	31
Check the contents of the crate.....	2	Mesh Panel.....	31
Securing the site while work is in progress	2	Rock Face 1200 / 1600 / 2000 / 240.....	32
Reading the plans.....	3	Rock Panel and Safety Panel (Under and Over)	32
Uprights, Platforms and Fasteners.....	4	Clock, Kaleidoscope, Port Hole, Observation and Xylophone Panels.....	33
Flanges5		Panels (Under platform).....	33
Clamp Assembly	5	Toddler Panels.....	33
Chain Housing Connections.....	5	Slat Panel.....	38
Determining Spacing between Uprights	6	Mesh Panel.....	38
Concrete Footings	6	Counting Panel	38
Ropes or Chains in ground	7	Squeeze Panel	39
Loctite 7		Clock, Kaleidoscope, Port Hole, Observation and Xylophone Panels.....	39
Fasteners.....	8	Slat Counter.....	40
Access, Entrance Panels and Handgrips	10	Spiral Abacus	40
Abseil 1600 / 2000	11	Platform Buffers	40
Arch Webs / Half Arch Webs.....	11	Pod Crossing.....	40
Cargo Rope Nets.....	11	Poles	41
Cliff Climber.....	12	Pommel Joiners / Pommel Walkers.....	41
Congo Net	12	Rock Joiners.....	42
Combat Climber Aly 1200/1600.....	13	Roller Bed 2p	42
Crest Climber.....	13	Rope Climber.....	43
Cube 3P	14	Rope / Scatter / Plank Walk / Plank Walk (Over 2M) / Ravine Bridge joiners	44
Cube 3P & Slide	15	Rope Seat	45
Cube 3P & 2 Slides.....	17	Rope Twist.....	45
Cube 4P	19	Roofs	46
Cube 4P & Slide	21	Curved Roof.....	46
Cube 3P and 4P 2 Ladders.....	22	Pitch Roof.....	46
Cube 3P and 4P 2 Pommels.....	23	Tilt Roof.....	46
Cube 3P and 4P Balance Beam.....	23	Pergola Roof Timber (double and quadruple).....	47
Cube 3P and 4P Rung Net	23	Slat Roof Aly / Timber (single, double and quadruple)	47
Cube 3P and 4P Side Stairs.....	23	“S” Climber	48
Cube 3P and 4P Top Joiners	24	Rung / Roll Over Bar.....	48
End Frame Joiner.....	24	Rubber Seat.....	48
Grid Joiners	24	Slide – Straight, Wave, Curved, Double.....	49
Horizontal Web and Horizontal Web to Platform	25	Spider Net	50
Inclined Webs.....	25	Spiral Tunnel Slides Under 2400.....	50
Ladder Rung	26	Spiral Tunnel Slides Over 2400.....	51
Ladder Wave	26	Spiral Tunnel Slide Barrier for Slides 2400 and Over .	53
Overhead Items.....	27	Slide Tunnel Plastic Curved 2000	53
Panels (Over platform)	29	Slide Tunnel Plastic Curved 3400	54
Binocular / Telescope Panel	29	Slide – Tunnel Curved 2400.....	54
Slat Panel.....	29	Stairs	55
Slat Filler.....	29	Step	56
Slat Infill (800, 1200, 1600 and 2000).....	30		
Offset Panel.....	30		
Entrance Tunnel Panel	30		

Steppers 200/400/600	56
Step Crossing.....	56
Step Ladder 800	57
Step Traverse	57
Stepping Stones - 2P, 2P Inc. 800, 3P and 3P Inc. 800	57
Tube Net	58
Tunnel 1P/2P (Aly)	58
Tunnel 1P/2P (plastic panels).....	59
Tunnel Slides	59
Tunnel Slide – Supports.....	60
Voice Pipe.....	60
Walkways	60
Web Tunnels	61

Web Walls	62
Wobble Walker 3P	62
Z Balance Beam – 2P and 3P	62
Before Leaving the Site	63
Safety and Maintenance Inspections	63
Routine Visual Inspection.....	63
Operational Inspection.....	63
Comprehensive Inspection.....	64

Prepare the site

Before any installation you should be familiar with the requirements of AS 4685 (Parts 1-6) – 2021 “Playground equipment – safety requirements and test methods” (particularly relating to fall zone requirements), AS 4422:2016 “Playground surfacing – specifications, requirements and test method” (relating to the type and depth of your soft-fall surfacing), and AS 4685.0:2017 “Playgrounds and playground equipment – development, installation, maintenance and operation” (dealing with your site requirements and ongoing maintenance).

If you require advice, talk to one of our consultants. Some important things to remember are as follows:

1. Playground equipment is normally designed for installation on a flat level surface so you should ensure that your play area is prepared correctly.
2. Check that the site is clear of underground power and services before you commence digging.
3. Measure the site to ensure that it is large enough to allow for the correct fall zones between the equipment and the outside of the soft-fall surface and the correct distances between various items of equipment. If you are unsure of these requirements you should check with your Forpark representative.
4. Where possible, prepare the site to allow for any slides to face south. While not essential, this will minimise the heat build-up on the slide face during the hottest parts of the day.
5. For ease of installation, do not put the soft-fall surfacing in until after the equipment has been installed. Ensure that you allow for the required soft-fall depth when excavating the site. Any excavation should take place before commencing the installation of the equipment.

Equipment required for installation

1. Ratchet (or socket set) with ½” driver
2. Ratchet (or socket set) with 3/8” driver
3. 13mm drill bit for drilling platforms
4. Cordless drill
5. Shovel for digging holes (preferably long-handled)
6. If digging in hard ground, you may need a 300mm auger and a crowbar
7. Spirit level
8. ‘G’ clamps (for holding items in place before bolting)
9. String line
10. Wheelbarrow
11. ‘Vice-grip’ pliers (for closing ‘S’ hooks)
12. An axe (for cutting tree roots if they are in the way)
13. Concrete for footings
14. Bricks/pavers (to provide stability below ground where required)
15. Scaffolding/platform ladder/s where necessary
16. A basic first aid kit for emergencies
17. ‘Occupational Health and Safety’ plan and procedures if applicable

Check the contents of the crate

In addition to the equipment itself, you should have the following:

1. Plans of the play structure
2. Materials or packing list
3. Tri-lobe driver (driver with a rounded triangular head that fits onto your ½" driver)
4. Hex head Allen keys (where required)
5. Torx Driver (driver with a star-shaped head that fits onto your 3/8" driver)
6. Tech Screw Driver
7. Nuts and bolts, etc.
8. Touch up paint
9. Loctite

Securing the site while work is in progress

You should ensure that the worksite is clearly defined by some sort of barrier or a temporary fence to ensure that children or onlookers are not in danger of injury while you work. The concrete footings will need at least 24 hours to set so a barrier or fence will keep people off the equipment until it is ready to be used and until adequate soft-fall surfacing has been installed.

1. Preparation for installation
2. Before you commence installation, you should familiarise yourself with the general instructions found on pages 3 to 8 of this manual. The various individual items of your equipment will be covered later in the manual.
3. Once ready to commence installation you should lay out the equipment and ensure that you have all items detailed on the materials or packing list.
4. Group the numbered uprights, in order of their installation so that they are readily available as required (see "Reading Plans").
5. Lay the equipment out roughly on the ground to ensure that it fits within the prepared area and that all required fall zones are met.
6. Determine the proposed finished surface level and use a string line to set this level. This will help in ensuring that the platforms and other items are set at their correct height above ground level.

Reading the plans

You have been supplied with two types of plans, one showing the actual layout of the equipment and the other showing the position of the uprights. (See below for examples of both plans.)

The upright plan contains several squares representing each upright and their locations corresponding with the uprights in the equipment layout plan. The figures inside each square represent the upright number and the height of that upright, e.g. upright 1 (below) is 3.0m in length. The letters on the outside of each square provide the orientation of each upright in relation to the items to be attached. The corresponding upright number is marked on the bottom of each upright supplied (along with some other details as shown below). The upright number is always marked on side 'B'. When standing at the base of the upright and holding it in a horizontal position with side 'B' facing up, you will rotate the upright counter-clockwise to bring side 'C' to the face-up position and so forth.

Equipment Layout Plan
(As though looking down from above)

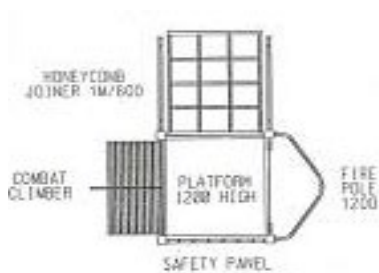

Upright Plan
(as though looking down on the uprights from above)

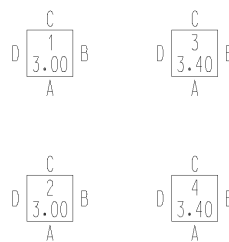

Upright Markings
(Base of each upright, always on side 'B')

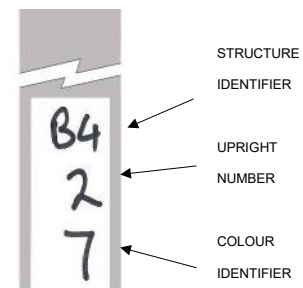

Installation

Uprights, Platforms and Fasteners

Uprights are pre-drilled with holes corresponding to the components to be attached. Aluminium uprights have a threaded insert fitted to each hole.

Each upright has a black plastic 75mm x 75mm cap inserted in the top and the base. If the base caps have not been inserted already, they will be supplied loose and should be inserted into the bottom of each upright before installing.

Each platform is installed at the height shown on the equipment layout plan (when measured from the top of the platform to the finished surface level below) and attached using 20mm tri-lobe bolts on each corner. Most platform styles allow for two bolts per upright.

Uprights should normally be installed to a depth of 800mm below the finished surface level. (If rubber surfacing has been specified the uprights may have been cut to allow 600mm below the finished surface level.) Make sure that you allow for the safety soft-fall surfacing when digging your holes, i.e., if the upright needs to be buried 800mm below finished surface level, and you have already excavated 300mm for soft-fall, the holes only needs to be 500mm deep. (Note: If the ground is soft or likely to be subject to settling it is best to dig the holes an additional 100mm deep and lay a 100mm thick footing using rapid-set concrete before inserting the uprights.)

Choose a platform as a starting point on the structure and prepare to install that platform. This could be in the centre of the structure to enable teams to work outwards in both directions at the same time. Before commencing the installation ensure that you have allowed for the correct fall zone between the equipment and the edge of the soft-fall surface.

To install the platform, place the uprights into the holes, ensuring that the identification numbers on the base of the uprights match the identification numbers on the upright plan. It may help to place a platform on the ground as a guide to enable you to work out the correct positioning of the upright holes. This initial platform will set the height for many of the other components to be subsequently attached, so its height in relation to the finished ground surface must be correct.

Once the uprights are in the holes at the correct height, lift the platform into place and fasten each corner to the upright by bolting from the underside of the platform into the upright using 20mm tri-lobes. Refer to the 'upright plan' to determine the correct orientation of each upright. It is important to make sure that the platform is level and at the correct height, and that the uprights are vertical.

Platforms require drilling for all items attached to them. Use the item's plan and the centre punches on the platform to find what holes need drilling and drill using a 13mm drill.

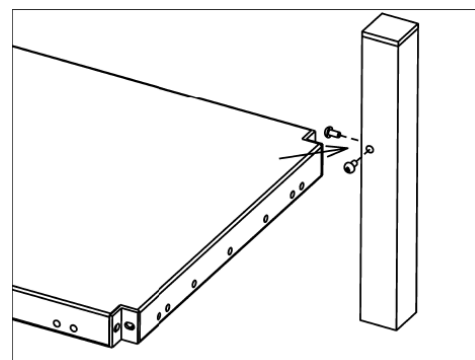

Attach any panels (both over and under the platform) as described in the section of this manual titled "panels". This will provide additional stability before the concrete is poured and sets.

Once satisfied that the platform is level and the uprights vertical, concrete the uprights and fill the holes, packing the soil firmly.

Note: Occasionally, due to human error, some holes in the uprights may be missed. Should this happen, you can drill the holes on-site. (You may need to check with your Forpark office first if unsure of the exact hole location.) For aluminium uprights a 13.5mm hole should be drilled and a threaded insert fitted.

Flanges

Many items connect to the uprights using moulded plastic flanges. These flanges will be included in the bolt packs. Square flanges are used on uprights that are square to the face of the platform.

In many cases, it may be easier to loosely fit the flanges in place on the component and then fasten the flanges to the upright. Each flange attaches to the upright using two 20mm tri-lobes (in some instances 25mm tri-lobes will be supplied and can be used).

Once satisfied that the uprights are correctly positioned and square, each flange can be secured to the component using a tech screw. A security cap should be used with each tech screw as shown, fitting the base to the screw before fastening. The tech screw is inserted through the dimpled hole in the side of the flange and into the steel pipe using a power drill and the tech screw driver supplied. Once secure, the top of the security cap should be securely fastened.

Before securing each item ensure that the spacing between uprights and platforms is correct as detailed below.

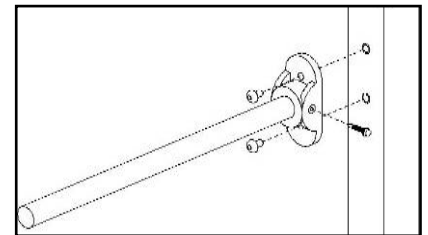
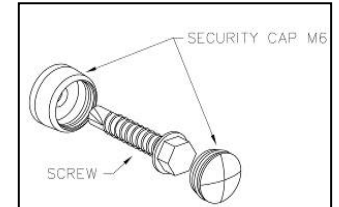
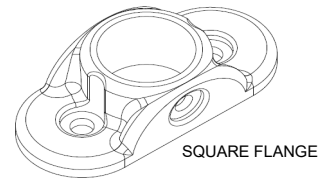

Clamp Assembly

Several items require the use of round clamps.

To attach the clamp place both halves on either side of the pipe. Join both halves together by using cap nuts and tri lobes 10 x 17 as shown. Slide the rope plug into the central hole and fasten using cap nuts and cup head bolts 10 x 60 as shown. When the clamp is in its final position tech screw into place ensuring security caps are fitted.

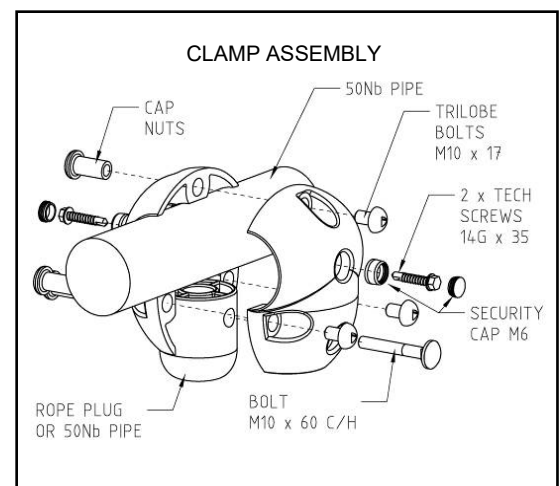

Chain Housing Connections

Several items have chains that attach to a top bar or rail. In these cases, the top bar or rail has chain housings connected. The chain should be inserted into the housing as far as it will go. An 8mm Torx bolt is then inserted into the hole in the housing, through the end link of the chain, securing the chain in place. Make sure a small amount of 'Loctite' is applied to the thread before tightening.

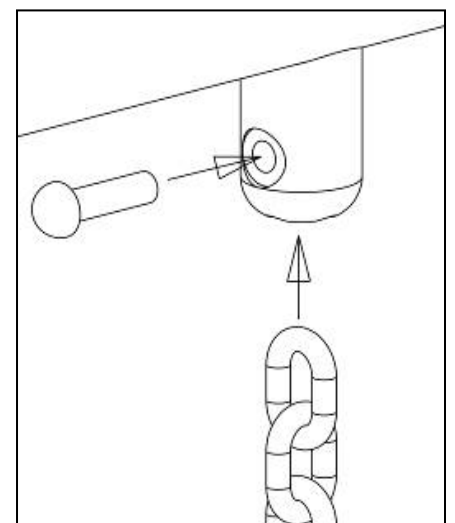

Determining Spacing between Uprights

Where handrails are used to determine the distance between platforms, a tape measure should also be used to check distances, allowing for movement in the flanges if they are not yet secured. Alternatively, a platform (or platforms) laid on the ground could be used as spacers. The distances between most components will be multiple of a single platform width.

The horizontal distances between opposing upright faces and platforms are as follows: -

Item length	Distance between upright faces	Distance between platform faces
1P	700mm	775mm
2P	1475mm	1550mm
3P	2250mm	2325mm
4P	3025mm	3100mm

Concrete Footings

We recommend that concrete be used on all uprights and items in the ground as per the diagram. The footings on uprights should be approximately 300mm x 300mm x 400mm (deep). Attachment components will generally only go 600mm below finished surface level and a smaller footing will be sufficient (approx. 300mm x 300mm x 300mm). All footings should have a tapered top so that water won't pool around the upright. Where loose fill surfacing is used ensure that the concrete is at least 300mm below the finished surface level or that the footing is effectively covered by items of equipment in such a way that they do not present a hazard. (Note: If the ground is soft or likely to be subject to settling it is best to use an additional 100mm of concrete on the footing below the upright. This may need to set before placing the upright in place.)

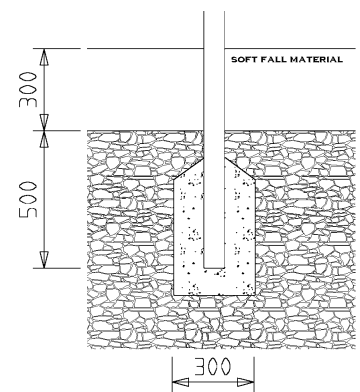

We recommend General Purpose Concrete. This is concrete with a compressive strength of 20MPa (at 28 days) or higher.

The concrete used in playground footings should only be mixed and/or worked by a suitably experienced person following the supplier/manufacturer's instructions.

Freestanding items may require a larger footing as detailed individually.

We trim 200mm off the square 75 uprights, in structures only, when a job is to be installed in rubber, this is done to make the installation easier as the post and footing do not need to be 800mm below FGL (600mm is sufficient).

The footing sizes are to remain the same as standard but will now be 200mm higher up the post. There will be no negative effects on the structural integrity of the structure when the post are installed in this manner.

Ropes or Chains in ground

Hang the rope or chain, mark and dig a hole in the ground approx. 700mm below finished ground level and 300mm x 300mm wide. Attach anchor with S hook, lower in the hole and concrete (footing approx. 300mm x 300mm x 400mm).

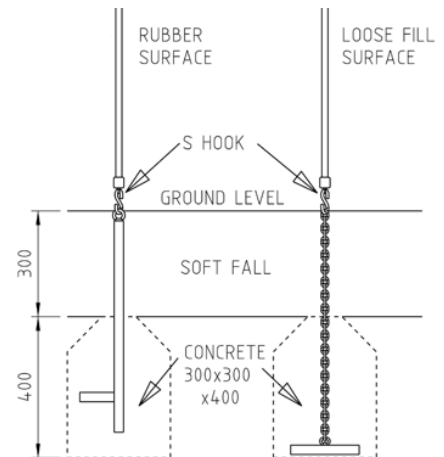

Loctite

'Loctite' is provided in each bolt pack. This should be used on any bolt used on items subject to movement or vibration. Where an item requires the use of 'Loctite' it is specified in this manual. (Examples of items typically requiring this are the boards on bridges and rope connectors.)

Where 'Loctite' is required only one to two drops need to be applied to the thread of the bolt, immediately before inserting into the nut and tightening.

Fasteners

All holes in aluminium uprights require nutserts (threaded inserts fitted in the holes). Regular tri-lobes are used when connecting to 'T' Nuts, Cap Nuts and nutserts.

In some instances, tri-lobe bolts will be replaced with Torx bolts. Both will do the same job. This will be particularly common where stainless steel fasteners are used.

The commonly used fasteners are shown below.

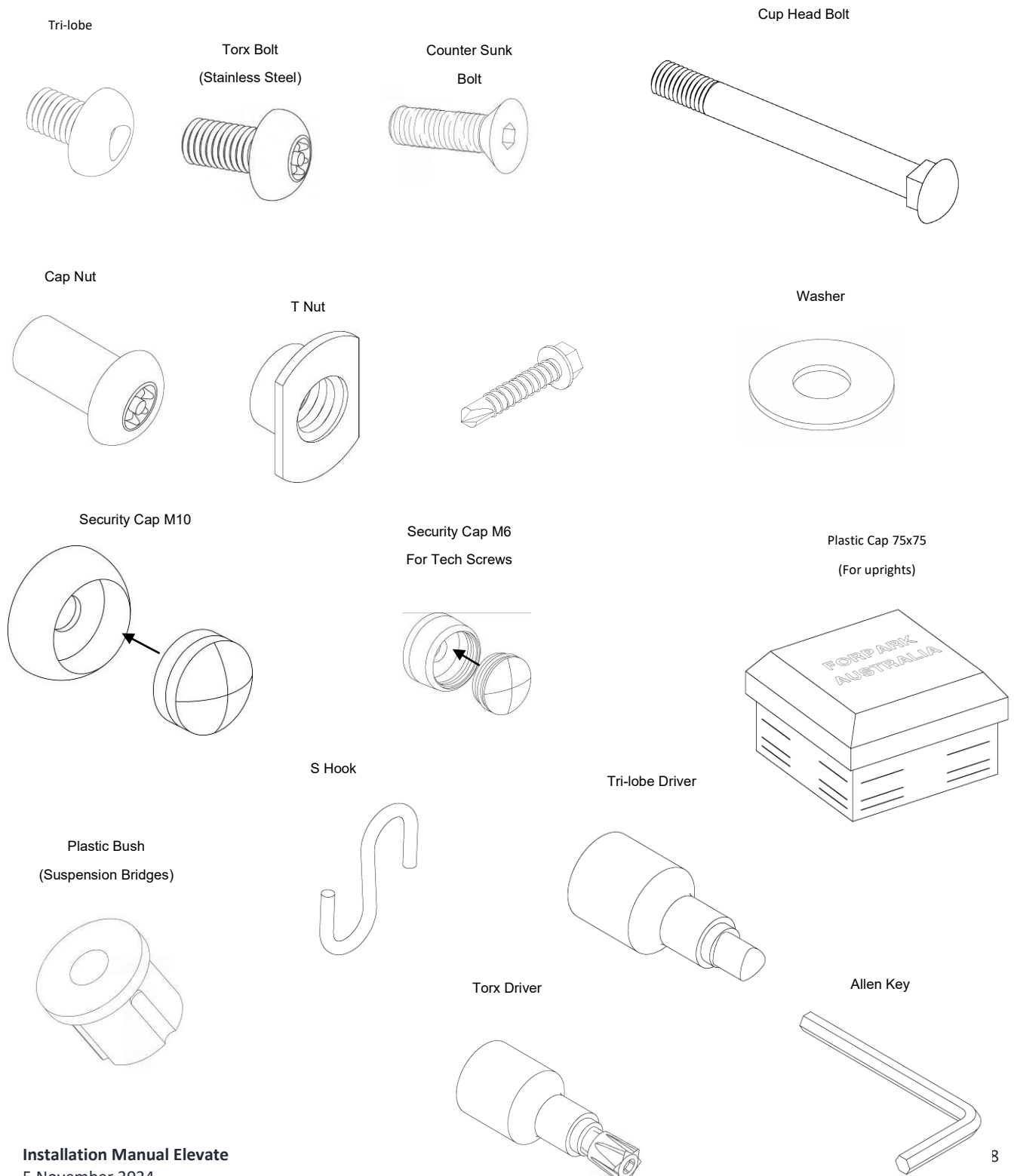

Please note that all S-Hooks should be fitted with the small loop attaching to the chain, and the large loop attaching to the connecting item (i.e., swing seat).

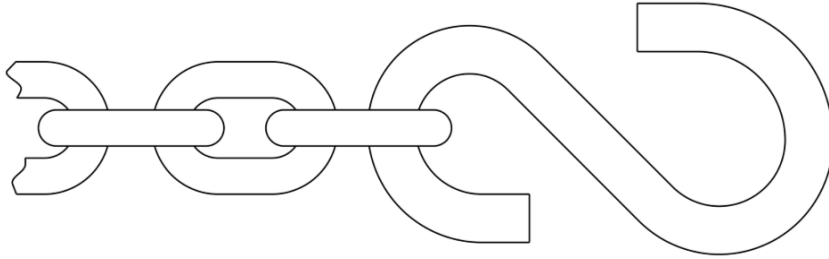

Installation – Playground Components

Access, Entrance Panels and Handgrips

IMPORTANT

When fitting a curved slide, spacers must be fitted between the handgrips and the metal section before assembly.

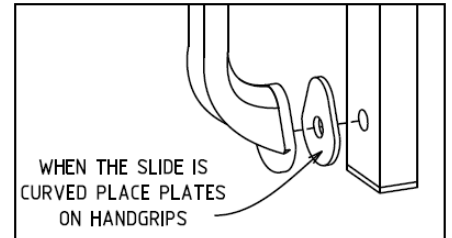

1. For the “Access Panel” use 10 tri-lobes 17mm (5 on each side).

2. For the “Entrance Panel Frame” use S/S bolts 10x60 Post Torx with S/S Washer M10 attaching handgrips and frame at the same time.

3. For the “Entrance Panel” use the same fittings as “Entrance Panel Frame” and bolt the aluminium panel to bars using tri-lobes 17mm.

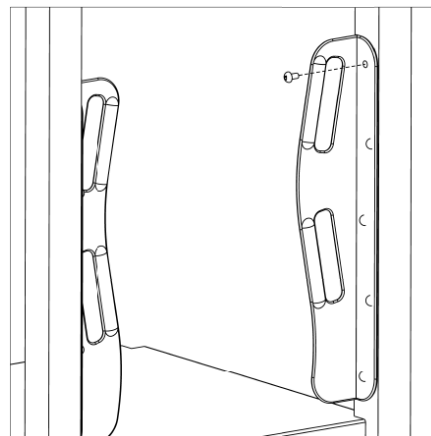

1. Access Panel

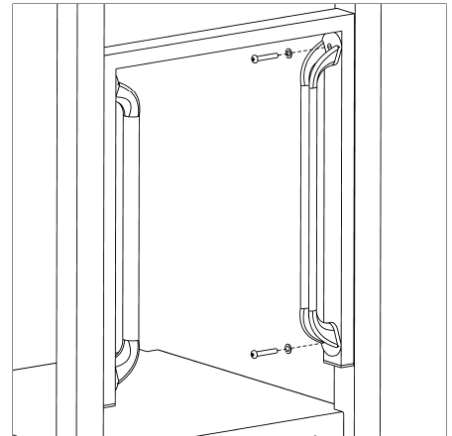

2. Entrance Panel Frame

4. For “Handgrips” use the same fittings as “Entrance Panel Frame”.

5. For “Access Panel – Plastic” attach the angle plates to uprights with Trilobes 17. Then plastic panels to angle plates with Trilobes 40 with washers M12x37 on one side and Security Caps + Nuts on the other side.

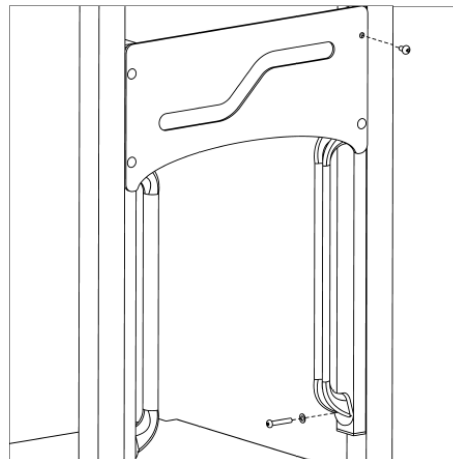

3. Entrance Panel

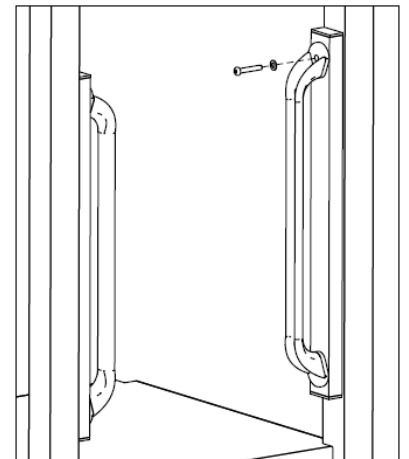

4. Handgrips

6. For “Entrance Panel Offset” attach the 3 supports to uprights with Trilobes 17. Join L shape plastic stripe to panel with bolts 35 Post Torx and Security Caps + Nuts. Handgrip to uprights with Trilobes 25.

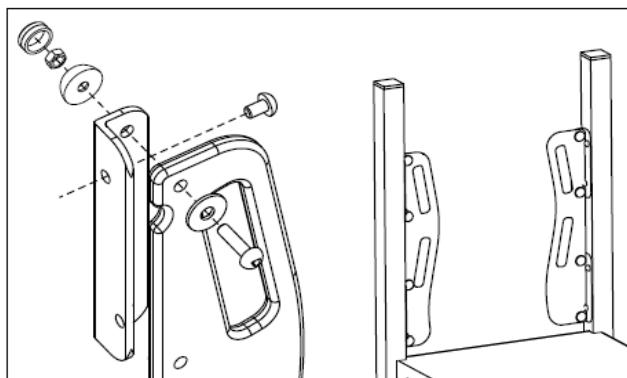

5. Access Panel - Plastic

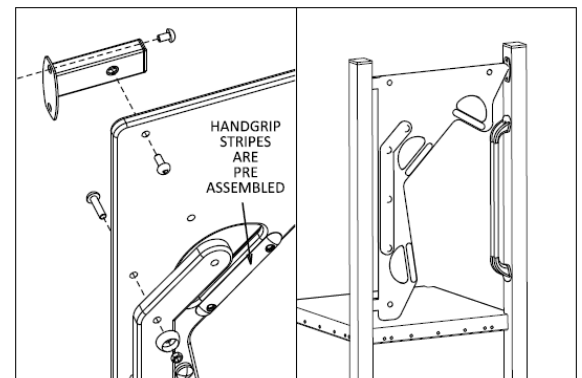

6. Entrance Panel Offset

Abseil 1600 / 2000

Use the leg to locate the correct position to dig the hole and attach it to the platform using Trilobes 17 and T-nuts.

Bolt the panels to the leg using Trilobe 20.

The rest of the assembly is the same as “Combat Climber Aly” from this manual.

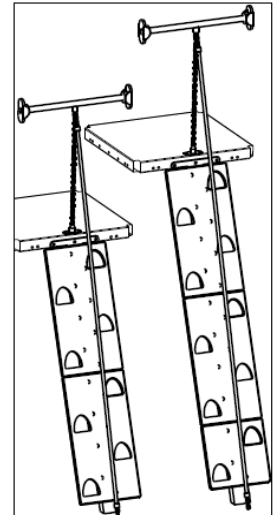
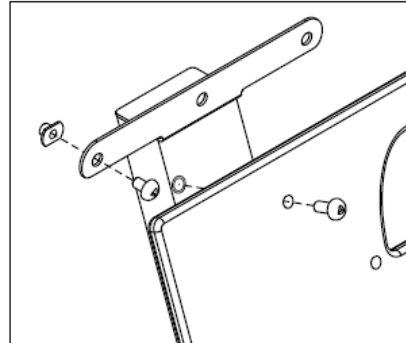

Arch Webs / Half Arch Webs

Dig the hole for the rail 800mm (below finished level), insert and attach rails with tri-lobes 20mm to uprights and clamp for rail to rail. Once all rails are in place, connect the rope net to the clamps and rails with standard Orbit clamp connections.

The Half Arch Webs have 2 arched rails concreted in the ground.

The difference to the 2900 webs is one more horizontal rope at the bottom.

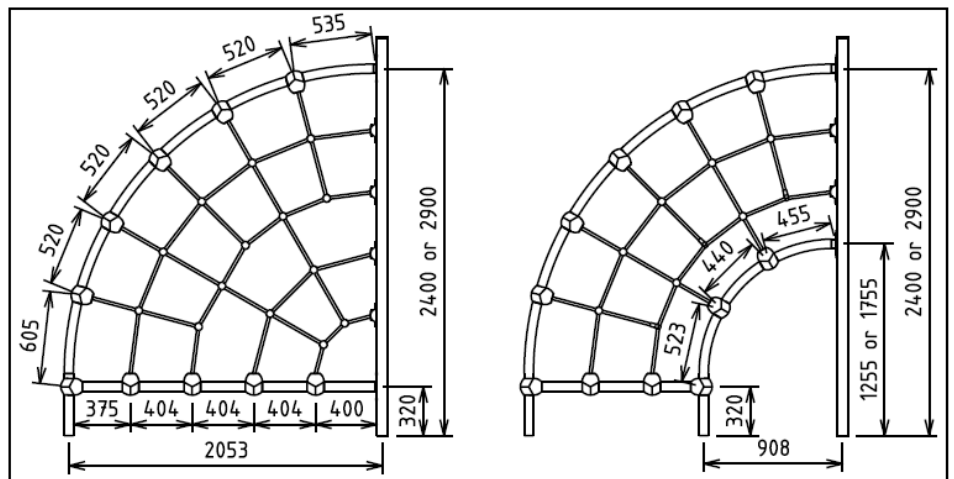

Cargo Rope Nets

Using platforms as a guide, determine the distance from one platform to the next, and dig holes for the uprights at the end of the handrails. (For exact distances see “Determining Distances between Uprights” at the front of this manual.) Place the uprights in the holes and ensure that their depth is correct. Attach handrails with 17mm tri-lobes to uprights. Dig holes for the uprights on the connecting platform and attach the platform.

Attach rope ends to housings with M8x28 post Torx and housings to platforms with square washer and 17mm tri-lobes. After ensuring that all bolts are tightened and that the platform and uprights are level and at the correct height concrete the footings in place.

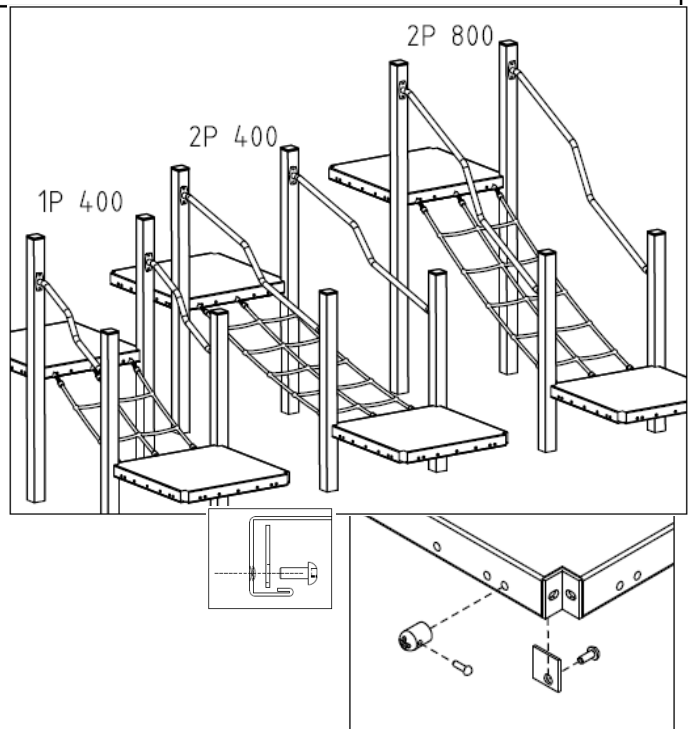

Cliff Climber

Use legs to locate the correct position to dig holes and attach the frame to the platform using 17mm tri-lobes and T-nuts. Attach the boards to the legs using 17mm tri-lobes and 25mm tri-lobes through rock grips. Once all bolts have been tightened concrete the legs into the ground.

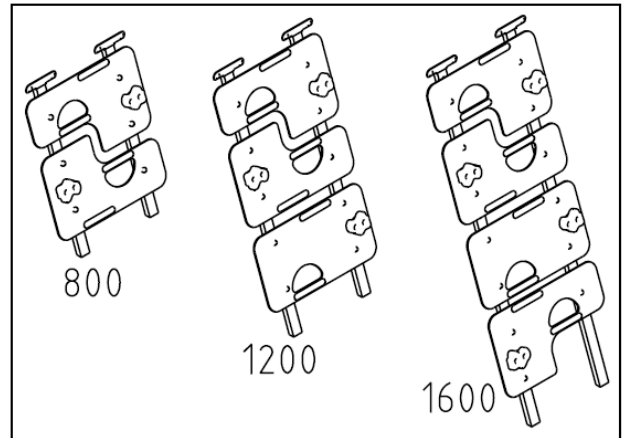
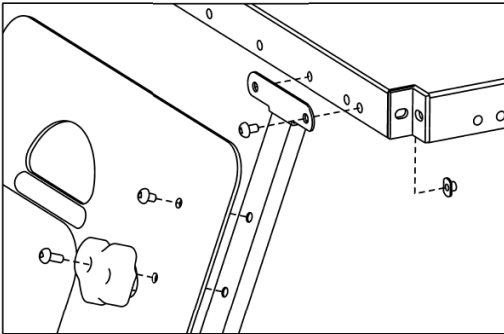

Congo Net

Attach rails according to plan with 17mm tri-lobes to uprights. The rope ends with a chain to rails with 8x28 post Torx. Standard connection of flanges to uprights. The bottom 2 ropes with eye nuts go to platforms with a square washer and 17mm tri-lobes from inside of platforms.

Use Loctite on all bolts. (Note: The net should be fitted so that the vertical ropes are on the inside of the net.)

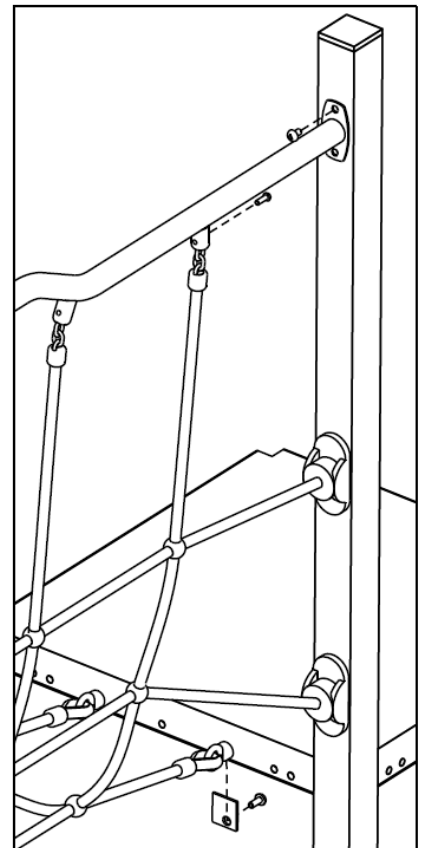
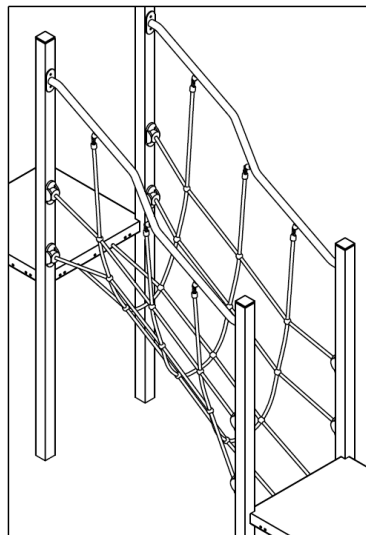
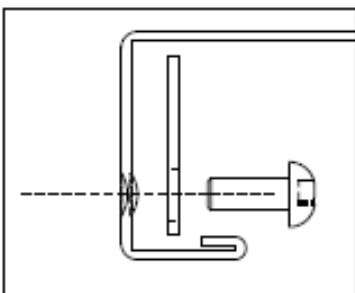

Combat Climber Aly 1200/1600

Place the flange on the platform as shown, mark and drill 10mm holes, then attach with 17mm trilobes and T-nuts. Remove chain links to have the chain tight.

Use the frame to locate the correct position to dig holes and attach the frame to the platform using 17mm tri-lobes and T-nuts. Attach the boards to the frame. Aluminium boards are fastened by a 40mm tri-lobe from the underside of the support beam.

Before the bolts are inserted you should apply a small amount of 'Loctite' to the thread. Connect the short chain to the top rail rails (as detailed under "chain housing connections" on page 5 of this manual). Join the long chain with a 6mm D shackle at the top of the short chain and to the bottom rail with an 'S' hook. Ensure the 'S' hook is closed fully using vice-grips.

Attach the flanges to the top rail (as detailed in "flanges" on page 5 of this manual) and attach to the uprights using 20mm tri-lobes. Once all bolts have been tightened concrete the legs into the ground.

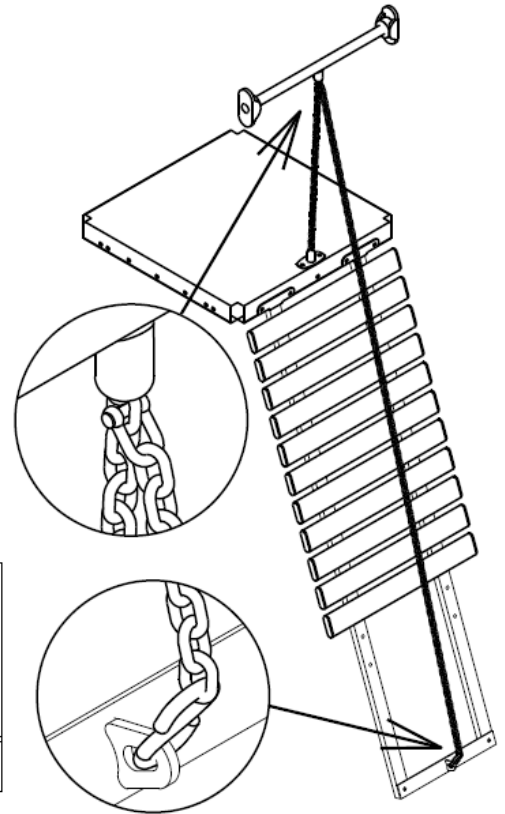
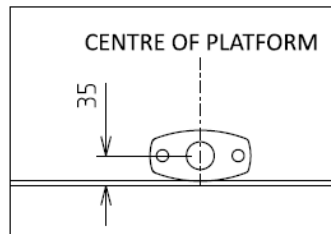

Crest Climber

Raise the item and attach the frame to the uprights with 20mm Trilobes. Bolt the separate rope to flanges with bolts M8 X 28 and flanges to uprights with 20mm Trilobes. Attach handgrips the same as the "Entrance Panel Frame" from page 10.

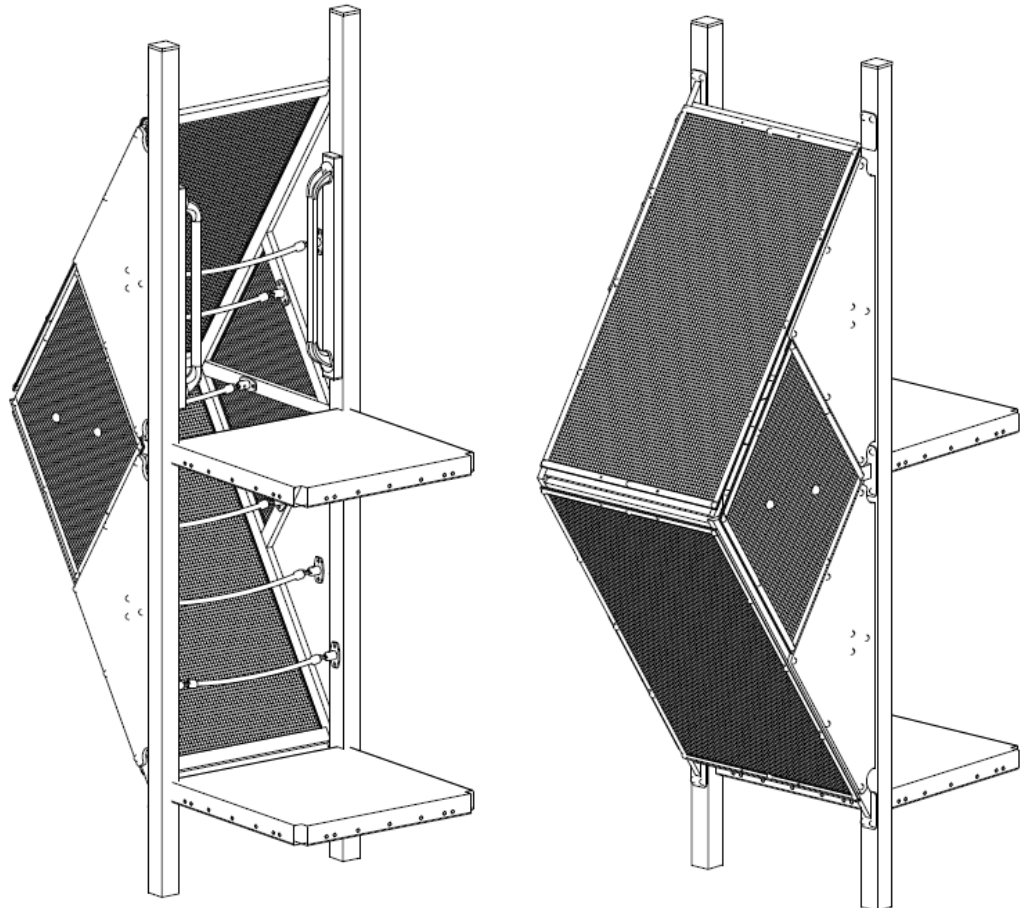

Cube 3P

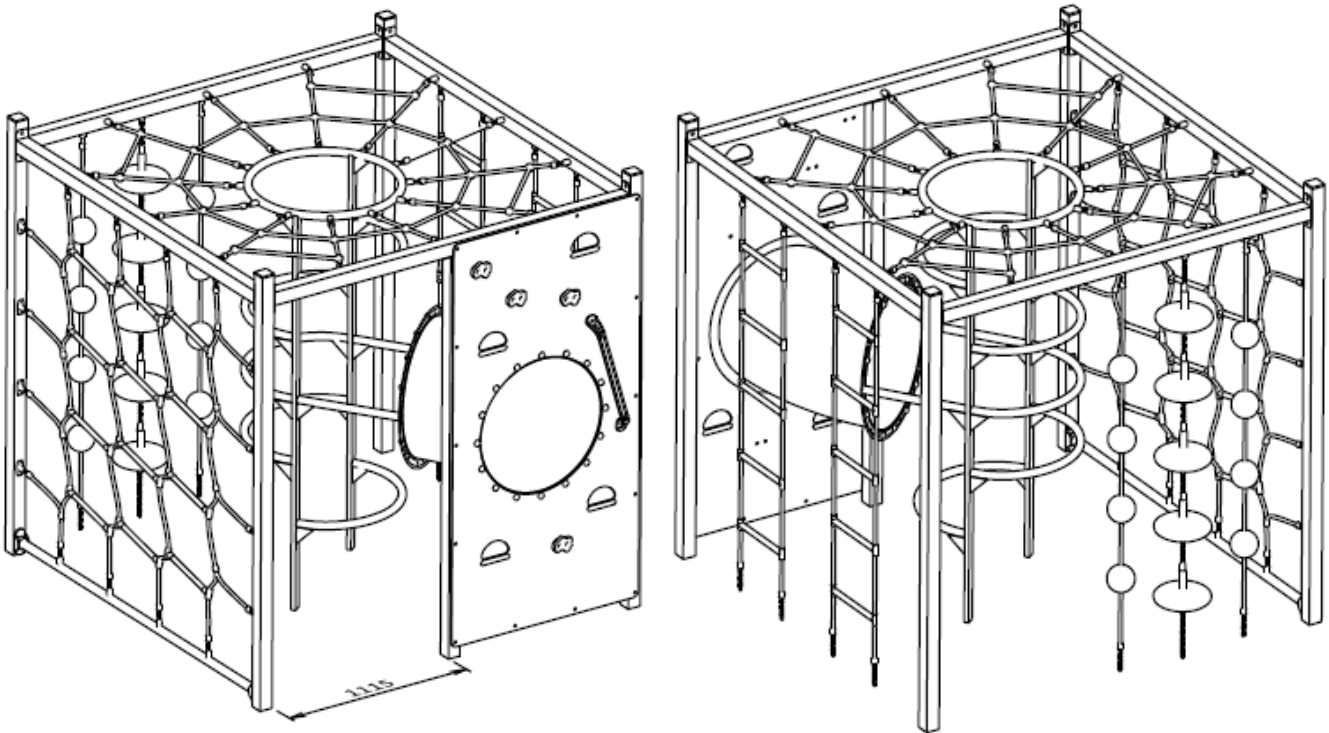

Connect uprights to horizontal upper and lower bars using Tri-lobes 10x20mm.

Mark and dig five (5) holes for the uprights 300mm x 300mm wide and 800mm below the finished ground level.

Position the frame in the holes ensuring the top of the upper horizontal bars is 2400mm above the finished ground level. The distance between the inside of each upright should be 2250mm (refer below).

Mark the position of the 2 legs of the steel frame and dig 2 holes 300mm x 300mm wide and 800mm below the finished ground level.

Attach the top net and the steel frame to it. Attach the aluminium panel to the structure with Tri-lobes 10x20mm and the tunnel section to the panel and the steel frame, as shown.

Attach all ropes with chain ends to the frames with bolts M8x25mm.

Hang the pommel chain, ball and ladder ropes, mark and dig holes in the ground approx. 600mm below finished ground level and 300mm x 300mm wide. Attach anchors to chains, lower in the holes and concrete footings (approx. 300mm x 300mm x 300mm).

Keeping the frame square with corner uprights and steel frame vertical, concrete footings 300mm x300mm x400mm (deep). Back fill holes with soil.

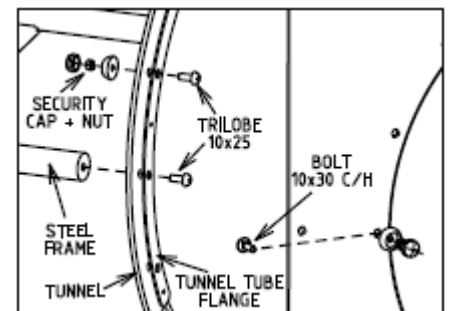
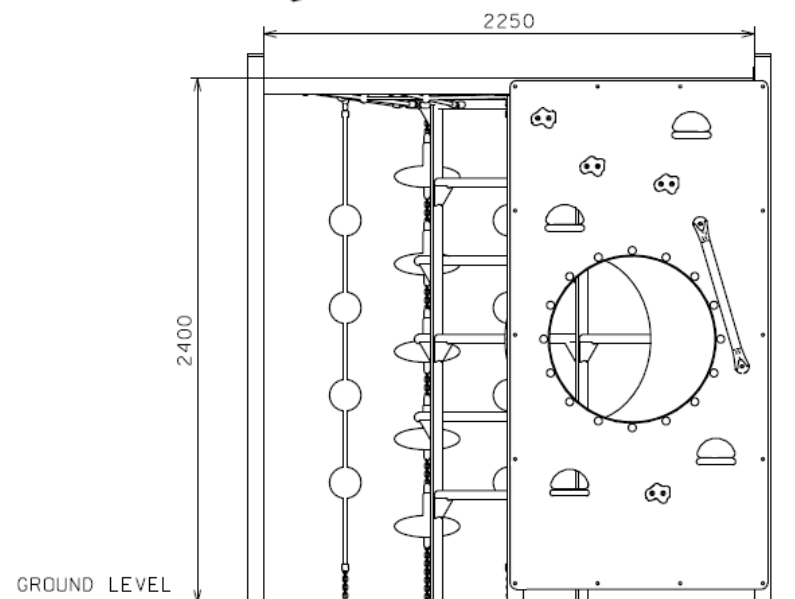

Cube 3P & Slide

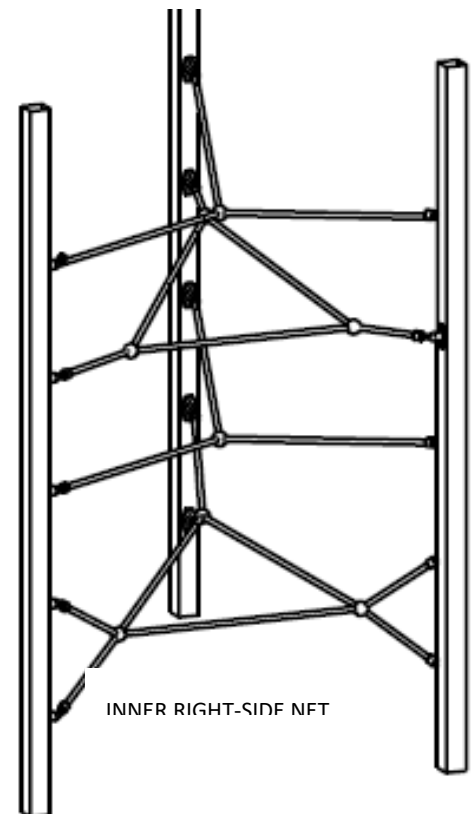
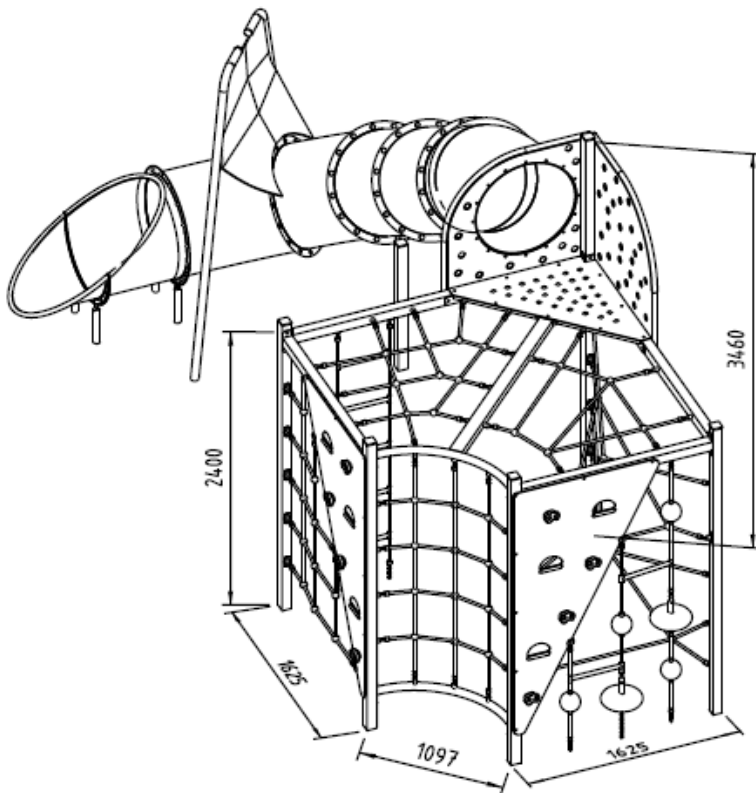

Connect uprights to horizontal upper and lower bars using Tri-lobes 10x20mm.

Mark and dig five (5) holes for the uprights 300mm x 300mm wide and 800mm below the finished ground level.

Position the frame in the holes ensuring the top of the upper horizontal bars is 2400mm above the finished ground level. Check the distance between the outside of the uprights as shown.

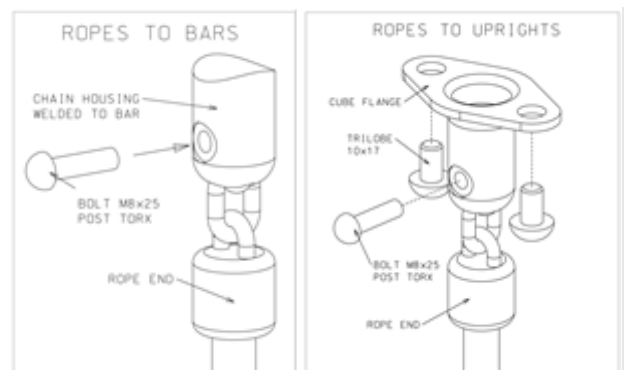

Attach the top net and the steel frame to it. Attach the aluminium panels to the structure with Tri-lobes 10x20mm.

Attach all ropes with chain ends to the frames with bolts M8x25mm.

Attach rope ends to all panels with washers, trilobes and cap nuts, as shown.

Hang the pommel chain, ball and ladder ropes, mark and dig holes in the ground approx. 600mm below finished ground level and 300mm x 300mm wide. Attach anchors to chains, lower in the holes and concrete footings (approx. 300mm x 300mm x 300mm).

Keeping the frame square with corner uprights and steel frame vertical, concrete footings 300mm x300mm x400mm (deep). Back fill holes with soil.

Connect the sections of the tunnel slide using 10x25 C/H bolts (except where the slide leg cradle attaches - 10x30 C/H bolts), nuts and security caps as shown. Connect the top section to the entry panel and keep going down, section after section.

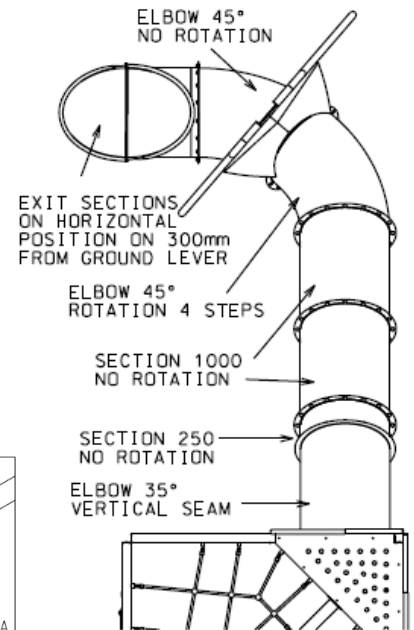
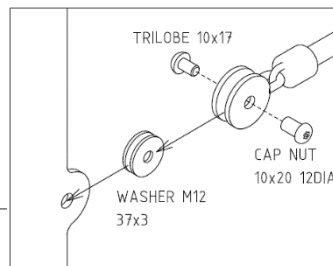

Check the plan for the type of slide and the number and type of

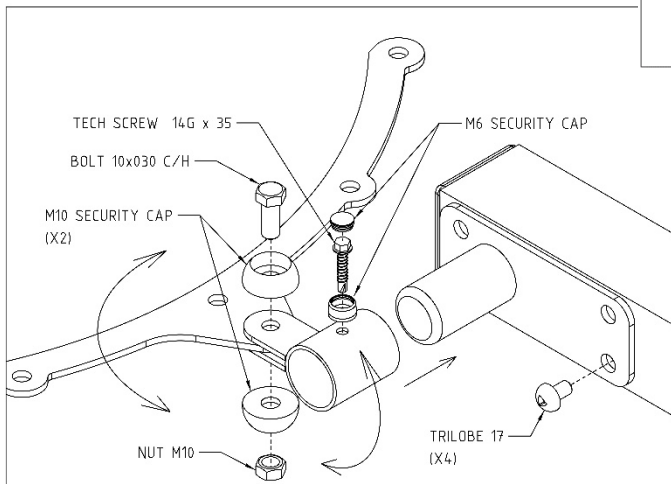

sections. Attach the slide legs to the support cradle using 'tap tight' tri-lobes. Each leg should be installed with the base 600mm below the finished ground level.

Use the slide as a guide to determine the position of the holes for the exit support legs and dig holes. It is advisable to place a brick or a block of wood below each leg to provide additional stability. Concrete the legs into the ground.

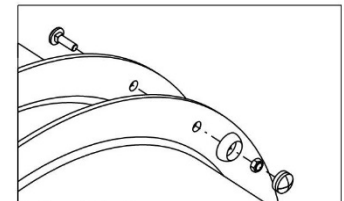

For the slide support, attach the joining plate to the upright with tri-lobes 10 x 17.—

Position the upright under the flange and attach the cradle in a suitable position. Join the plug to the cradle with the loose bolt. Insert the plug on the plate's pipe and secure it with the Tec Screw. Tighten the bolt and place the cover on the caps.

Attach rubber membrane to both supports with cup head bolts and security caps. Rise and position the frame above the tunnel flange you will attach the rubber. The flexible rubber will allow for both legs to keep a minimum distance of 250mm to the tunnel tube (no part of the tunnel should come closer than 250mm to the barrier support legs). The rubber should be tilted slightly forward of the exit as shown (check the dimensions). Mark the position for the holes in the ground. Dig the holes, insert the frame and bolt the rubber to the flange. If the last holes on the flange of the rubber don't match the holes on the tube's flange, drill the needed hole on the tube's flange.

Concrete, keeping the frame vertical.

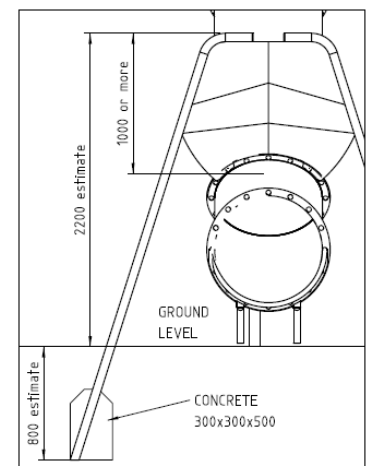

Cube 3P & 2 Slides

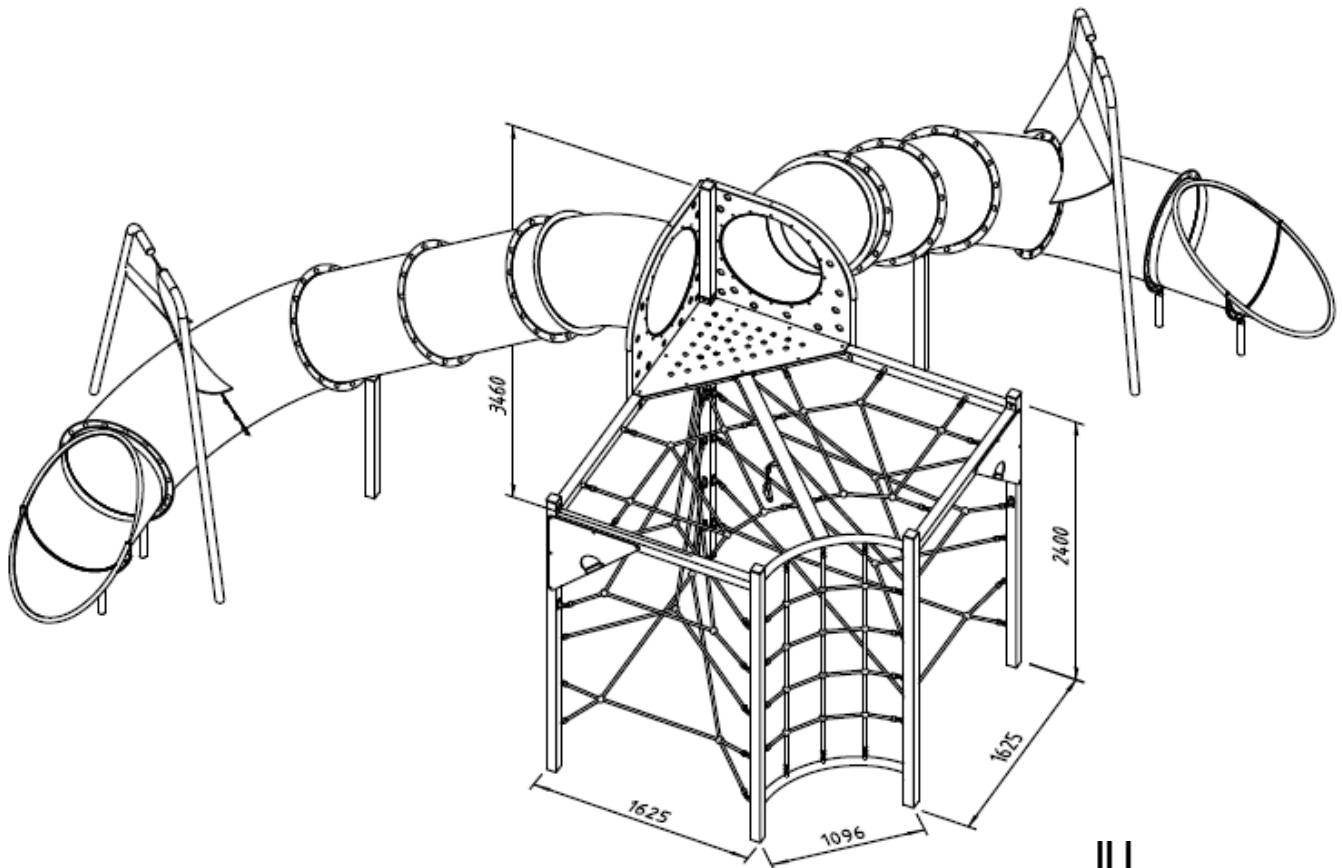

Connect uprights to horizontal upper bars using Tri-lobes 10x20mm.

Mark and dig five (5) holes for the uprights 300mm x 300mm wide and 800mm below finished ground level.

Position the frame in the holes ensuring the top of the upper horizontal bars is 2400mm above the finished ground level. Check the distance between the outside of the uprights as shown.

Attach the top net and the steel frame to it. Attach the aluminium panels to the structure with Tri-lobes 10x20mm.

Attach all ropes with chain ends to the frames with bolts M8x25mm.

Hang the pommel chain, ball and ladder ropes, mark and dig holes in the ground approx. 600mm below finished ground level and 300mm x 300mm wide. Attach anchors to chains, lower in the holes and concrete footings (approx. 300mm x 300mm x 300mm).

Keeping the frame square with corner uprights and steel frame vertical, concrete footings 300mm

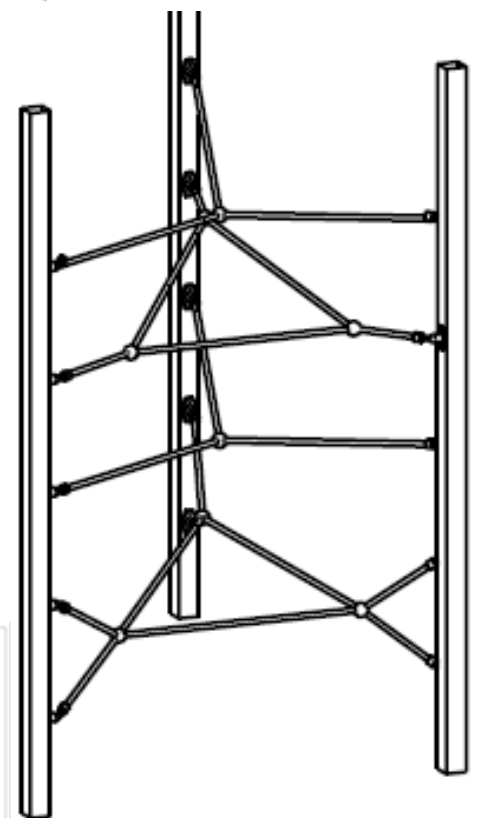
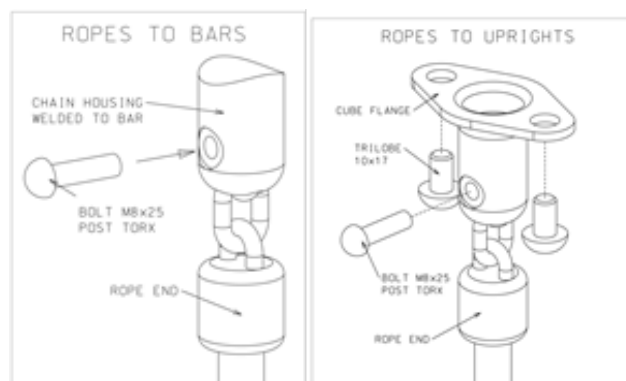

INNER RIGHT-SIDE NET
(LEFT ONE IS MIRRORED)

x300mm x400mm (deep). Back fill holes with soil.

Connect the sections of the tunnel slide using 10x25 C/H bolts (except where the slide leg cradle attaches - 10x30 C/H bolts), nuts and security caps as shown. Connect the top section to the entry panel and keep going down, section after section. Check the plan for the type of slide and the number and type of sections. For the

position of tunnel sections, the right slide is a mirror of the left one. Attach the slide legs to the support cradle using 'tap tight' tri-lobes. Each leg should be installed with the base 600mm below the finished ground level.

Use the slide as a guide to determine the position of the holes for the exit support legs

and dig holes. It is advisable to place a brick or a block of wood below each leg to provide additional stability. Concrete the legs into the ground.

For the slide support, attach the joining plate to the upright with tri-lobes 10 x 17.

Position the upright under the flange and attach the cradle in a suitable position. Join the plug to the cradle with the loose bolt. Insert the plug on the plate's pipe and secure it with the Tec Screw. Tighten the bolt and place the cover on the caps.

Attach rubber membrane to both supports with cup head bolts and security caps. Rise and position the frame above the tunnel flange you will attach the rubber. The flexible rubber will allow for both legs to keep a minimum distance of 250mm to the tunnel tube (no part of the tunnel should come closer than 250mm to the barrier support legs). The rubber should be tilted slightly forward of the exit as shown (check the dimensions). Mark the position for the holes in the ground. Dig the holes, insert the frame and bolt the rubber to the flange. If the last holes on the flange of the rubber don't match the holes on the tube's flange, drill the needed hole on the tube's flange.

Concrete, keeping the frame vertical.

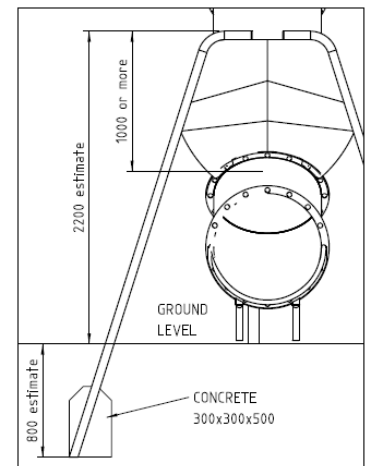
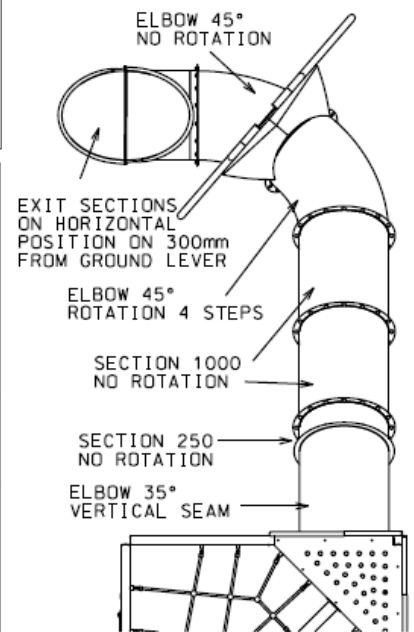
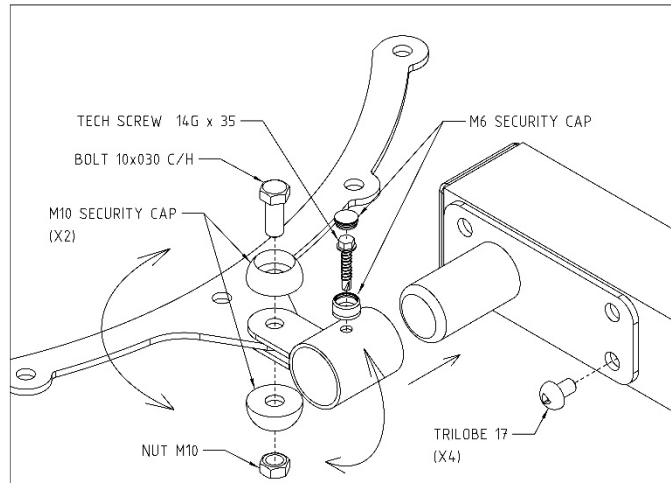
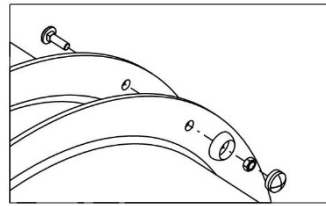

Cube 4P

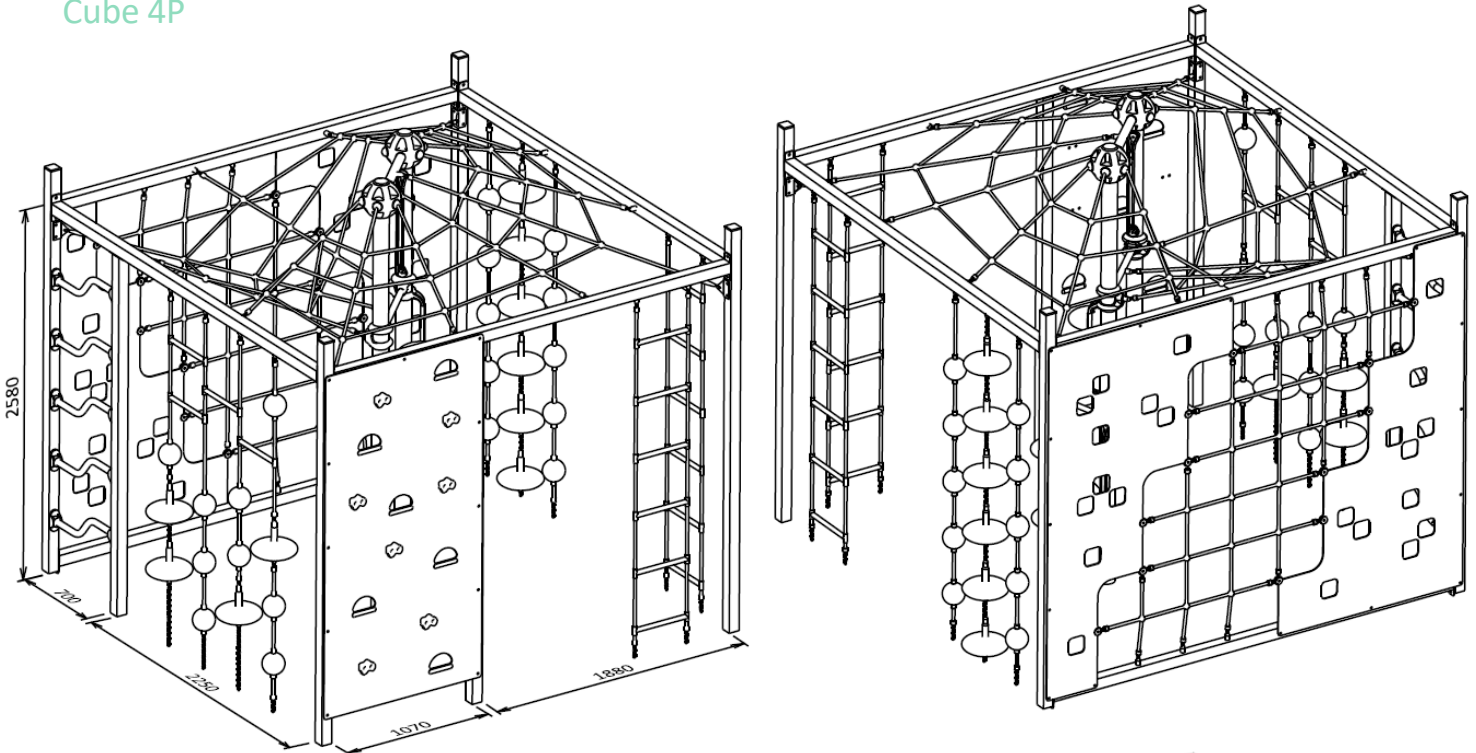

Connect uprights to horizontal upper and lower bars using Tri-lobes 10x20mm.

Mark and dig four (4) holes for the uprights 300mm x 300mm wide and 800mm below the finished ground level.

Position the frame in the holes ensuring the top of the upper horizontal bars is 2580mm above finished ground level. The distance between the inside of each corner upright should be 3025mm. Mark and dig 2 of the same holes for the steel ladder and rock wall panel uprights. Attach the steel ladder and rock panel with the 2 middle uprights.

The concrete for all 8 uprights is 300x300mm, deep 500mm.

Mark the position of the 2 posts in the centre and dig 2 holes 300mm x 300mm wide and 800mm below finished ground level.

Attach all ropes with chain ends to the frames with bolts M8x25mm.

Hang the pommel chain, ball and ladder ropes, mark and dig holes in the ground approx. 600mm below finished ground level and 300mm x 300mm wide. Attach anchors to chains, lower in the holes and concrete footings (approx. 300mm x 300mm x 300mm).

Attach the panel/rope wall to the structure with Tri-lobes 10x20mm.

Attach rope ends to all panels with washers, trilobes and cap nuts, as shown.

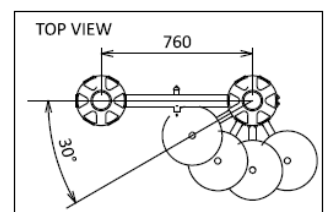
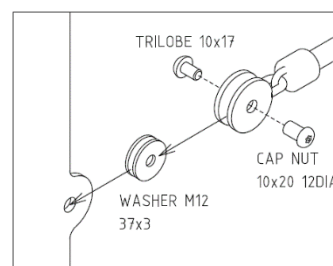
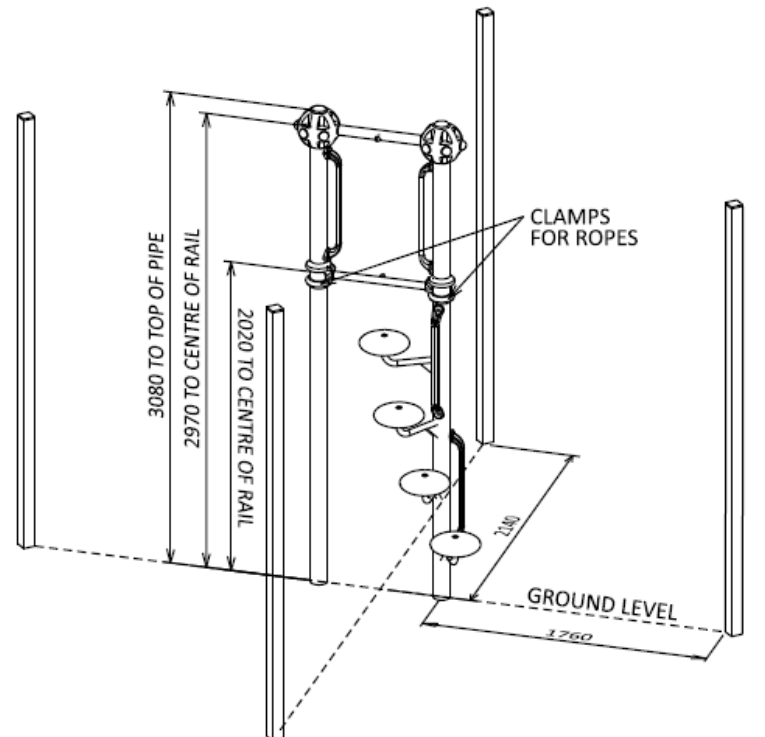

Attach the top net to the posts and tighten turnbuckles to the corner uprights. "Clamp to rope plugs" are 2 from the gym clams and 8 from the star clamps. Tighten the turnbuckles.

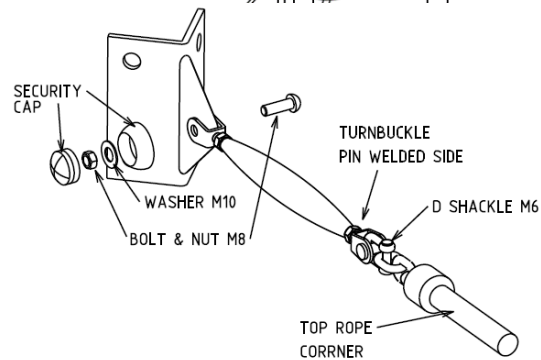
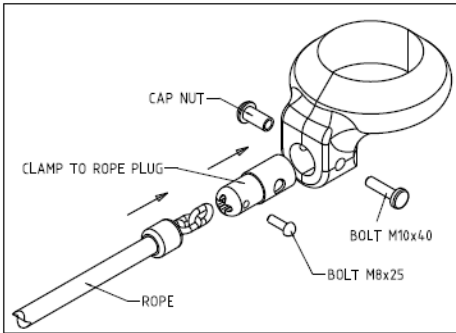
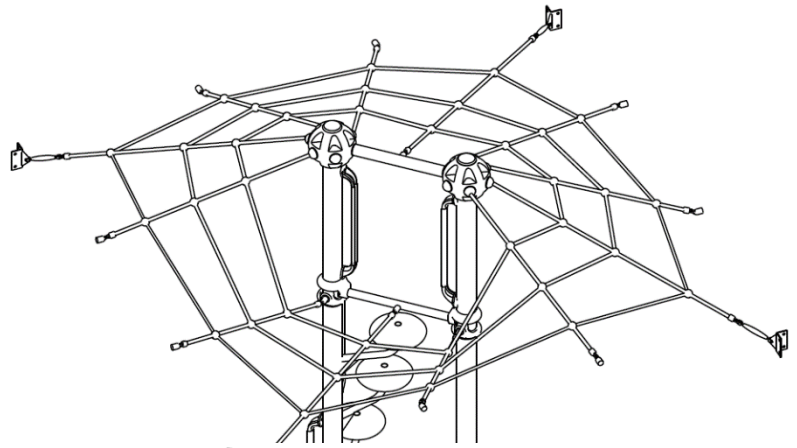

STAR JOINT

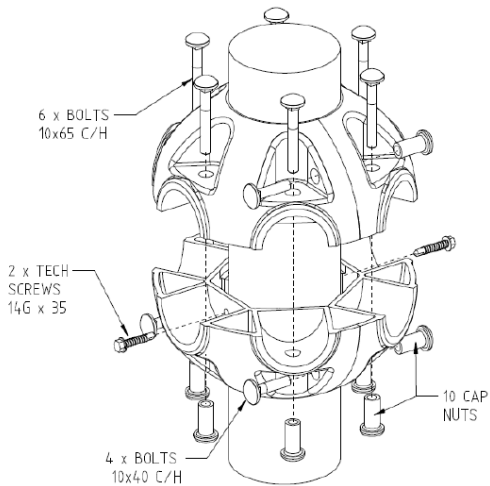

Keeping the frame square with corner uprights and 2 posts vertical, concrete footings 300mm x300mm x400mm (deep). Back fill holes with soil.

Cube 4P & Slide

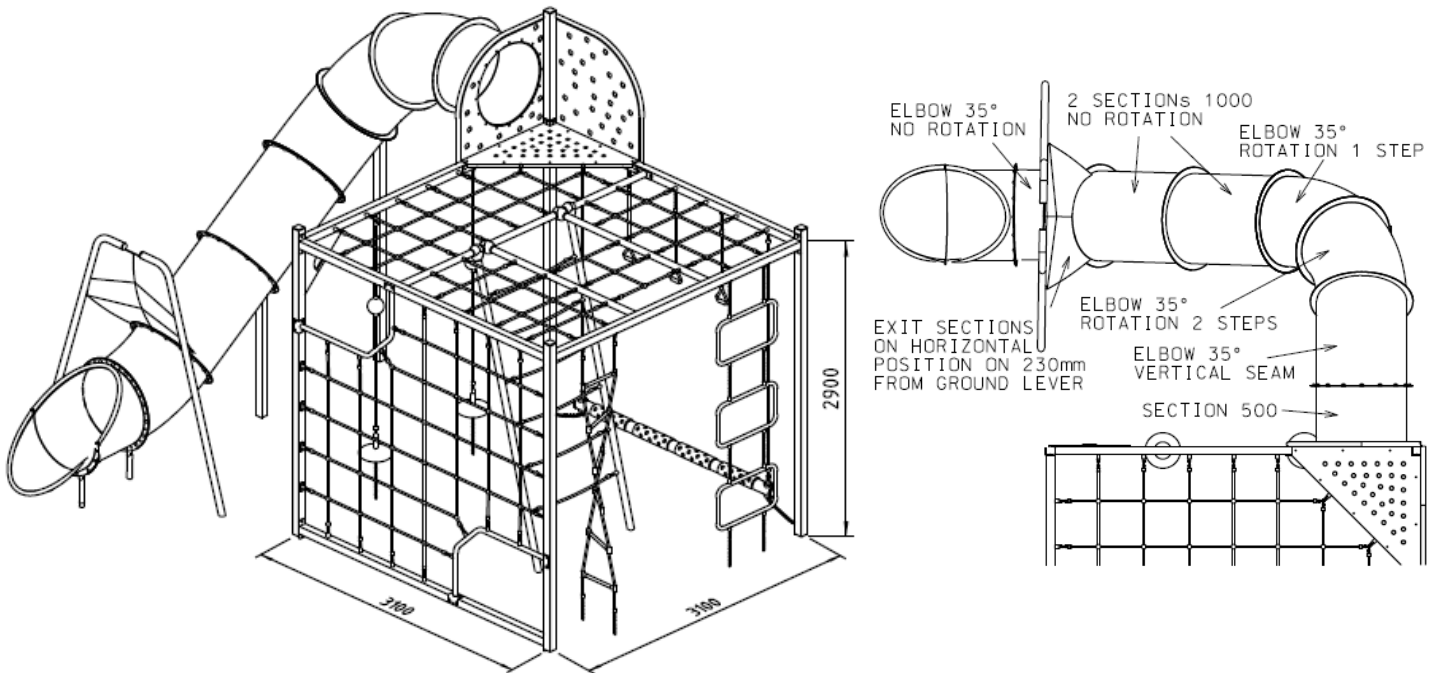

Connect uprights to horizontal upper and lower bars using Tri-lobes 10x20mm.

Mark and dig five (5) holes for the uprights 300mm x 300mm wide and 800mm below the finished ground level.

Position the frame in the holes ensuring the top of the upper horizontal bars is 2900mm above finished ground level. Check the distance between the centre of the uprights as shown.

Attach the pipe frame at the top. Attach the 6 ropes to the supporting bars. Attach the 2 supporting bars using clams to the top pipe frame, place them at 15 degree angle and stretch them until the ropes are tight. Mark and dig the holes 300x300x600 deep.

Attach the triangle aluminium panels to the structure with Tri-lobes 10x20mm.

Attach all ropes with chain ends to the frames with bolts M8x25mm.

Hang the pommel chain, ball and ladder ropes, mark and dig holes in the ground approx. 600mm below finished ground level and 300mm x 300mm wide. Attach anchors to chains, lower in the holes and concrete footings (approx. 300mm x 300mm x 300mm).

Keeping the frame square with corner uprights and steel frame vertical, concrete footings 300mm x300mm x400mm (deep) and 300x300x300 to the inner supports. Back fill holes with soil.

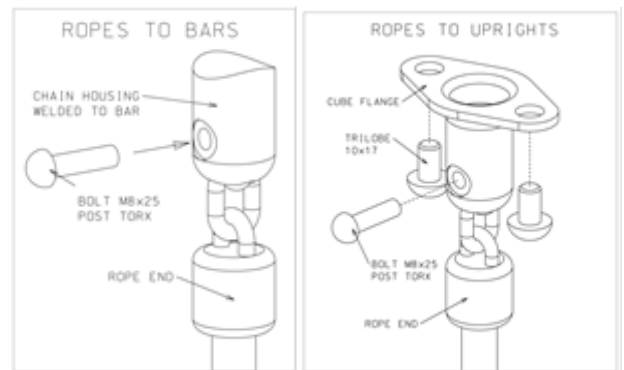

Connect the sections of the tunnel slide using 10x25 C/H bolts (except where the slide leg cradle attaches - 10x30 C/H bolts), nuts and security caps as shown. Connect the top section to the entry panel and keep going down, section after section. Check the plan for the type of slide and the number and type of sections. Attach the slide legs to the support cradle using 'tap tight' tri-lobes. Each leg

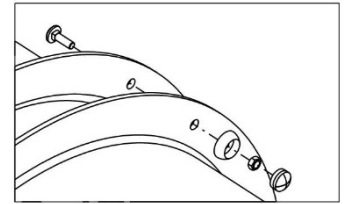

should be installed with the base 600mm below the finished ground level.

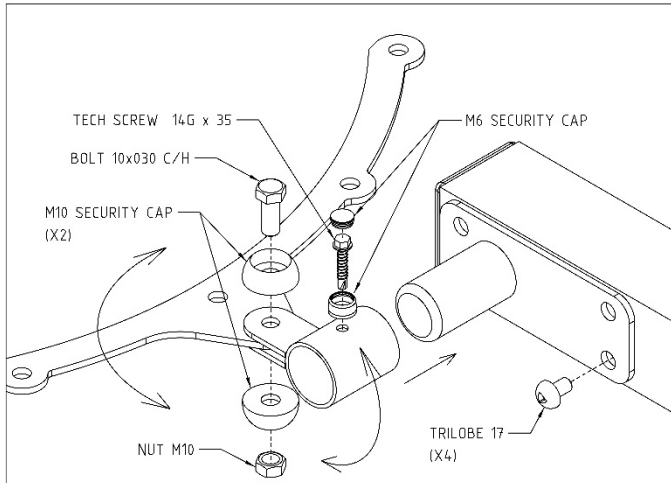

Use the slide as a guide to determine the position of the holes for the exit support legs and dig holes. It is advisable to place a brick or a block of wood below each leg to provide additional stability. Concrete the legs into the ground.

For the slide support, attach the joining plate to the upright with tri-lobes 10 x 17.

Position the 2 uprights under the flanges and attach cradles in a suitable

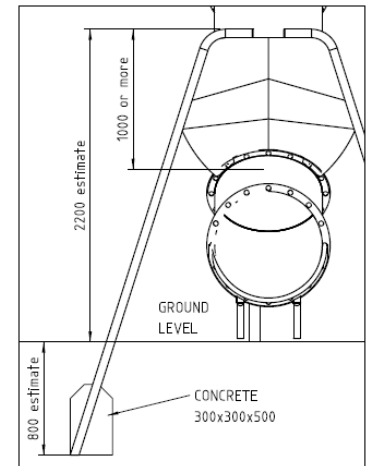

position. Join the plug to cradles with loose bolts. Insert the plug on the plate's pipe and secure it with the Tec Screw. Tighten the bolts and place the cover on the caps.

Attach rubber membrane to both supports with cup head bolts and security caps. Rise and position the frame above the tunnel flange you will attach the rubber. The flexible rubber will allow for both legs to keep a minimum distance of 250mm to the tunnel tube (no part of the tunnel should come closer than 250mm to the barrier support legs). The rubber should be tilted slightly forward of the exit as shown (check the dimensions). Mark the position for the holes in the ground. Dig the holes, insert the frame and bolt the rubber to the flange. If the last holes on the flange of the rubber don't match the holes on the tube's flange, drill the needed hole on the tube's flange.

Concrete, keeping the frame vertical.

Cube 3P and 4P 2 Ladders

These items are attached on the left or right side of the Top Joiners. Position and bolt the clamps at mid-distance to the net squares. Place the 4 ropes vertically, and mark and dig holes for the anchors. Attach and concrete the anchors.

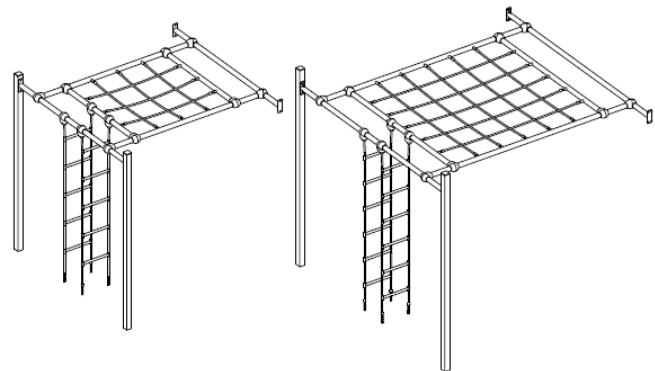

Cube 3P and 4P 2 Pommels

These items are attached on the left or right side of the Top Joiners. Position and bolt the clamps at mid-distance to the net squares. Place the 4 ropes vertically, and mark and dig holes for the anchors. Attach and concrete the anchors.

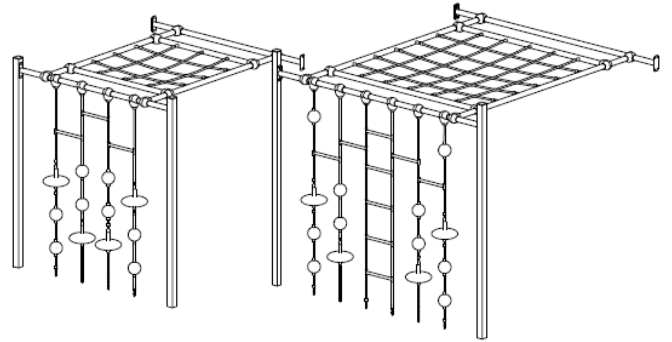

Cube 3P and 4P Balance Beam

These items are attached on the left or right side of the Top Joiners. Bolt flanges to uprights with trilobes 20. Position and bolt clamps at equal distances, with the first and last one just outside the clams of the Top Joiner.

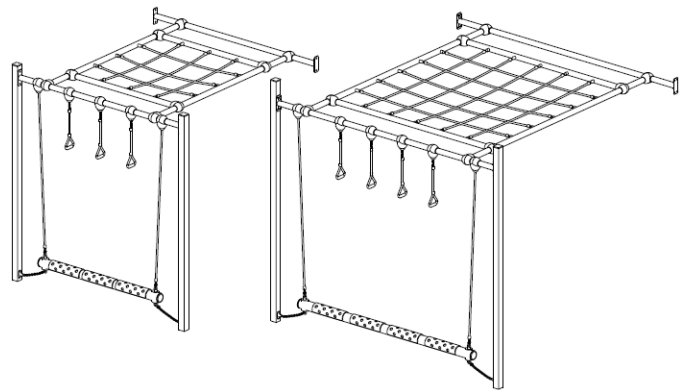

Cube 3P and 4P Rung Net

These items are attached on the left or right side of the Top Joiners. Bolt bottom rail to uprights with trilobes 20. Position and bolt clamps at equal distances, with the first and last one no more than 100mm from uprights.

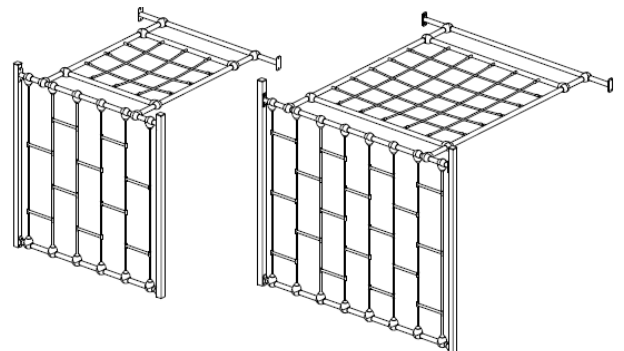

Cube 3P and 4P Side Stairs

These items are attached on the left or right side of the Top Joiners. Position and bolt the clamps at mid-distance to the net squares. Place the 2 ground ropes vertically, and mark and dig holes for the anchors. Attach and concrete the anchors.

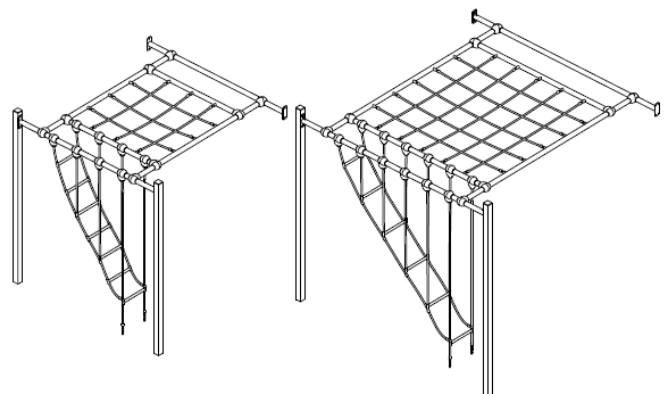

Cube 3P and 4P Top Joiners

These items connect 3P and 4P cubes to other cubes or structures. Assemble all clamps without screws, stretch the net an equal distance from the end of the rungs and screw the clamps. Rise the frame and attach it to the uprights with Trilobes 20.

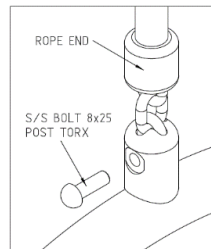
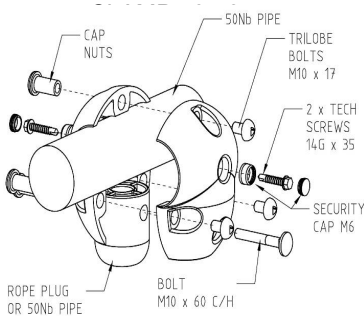
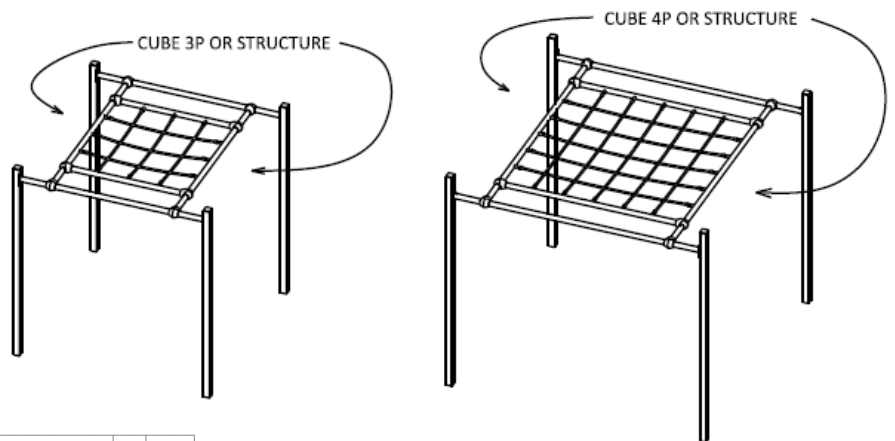

End Frame Joiner

End frame joiners are used as a connector for items that would normally join onto the face of a platform when the platform is not needed. The end frame joiner is bolted between the two end uprights using 25mm tri-lobes. Items are then attached in general to the end frame joiner using stainless steel cap nuts and 30mm cup head bolts.

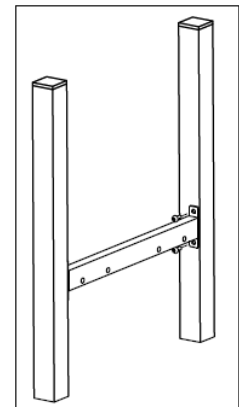

Grid Joiners

Using a platform as a guide to determine the distance from one platform to the next, dig holes for the uprights at the opposite end of the handrails. (For exact distances see "Determining Distances between Uprights" at the front of this manual.) Place the uprights in the holes and ensure that their depth is correct. Attach handrails with 17mm tri-lobes to uprights and grid joiner to platforms with 17mm tri-lobes from the platform side. After ensuring that all bolts are tightened and that the platform and uprights are level, and at the correct height, concrete the footings in place.

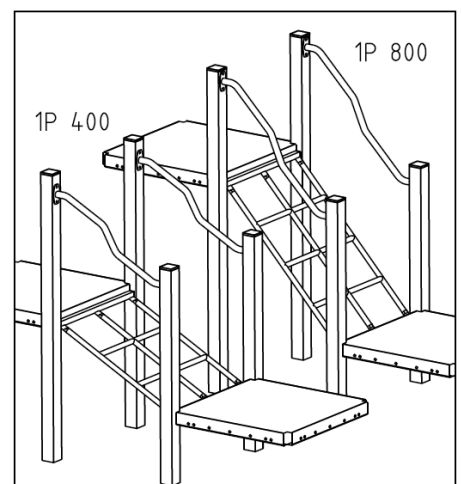

Horizontal Web and Horizontal Web to Platform

Using the side rails as a guide to determine the distance between uprights, dig holes for the uprights at the end of the rails. (For

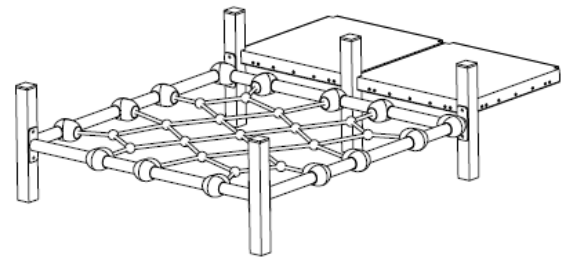
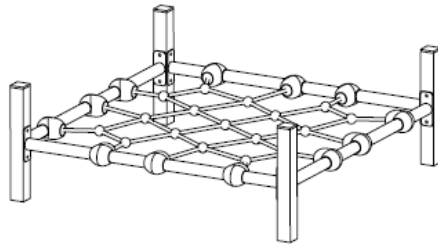

exact distances see “Determining Distances between Uprights” at the front of this manual.) After placing the uprights in the holes and ensuring that their depth is correct, bolt the rails to the uprights using 20mm tri-lobes.

Attach the clamps (that will be used to secure the ropes) to the rails according to the dimensions shown using 17mm tri-lobes and cap nuts. Before the bolts are inserted you should apply a small amount of ‘Loctite’ to the thread.

Fit the net by sliding the plugs on the end of the ropes into the hole at the end of each clamp and securing it in place using a 60mm cup head bolt and a cap nut. Before the bolts are inserted you should apply a small amount of ‘Loctite’ to the thread. Tension the ropes as required by gently sliding the clamps slightly along the rails (the shown dimensions are approximate) and then secure them in place using a tech screw on both sides of each clamp into the rail.

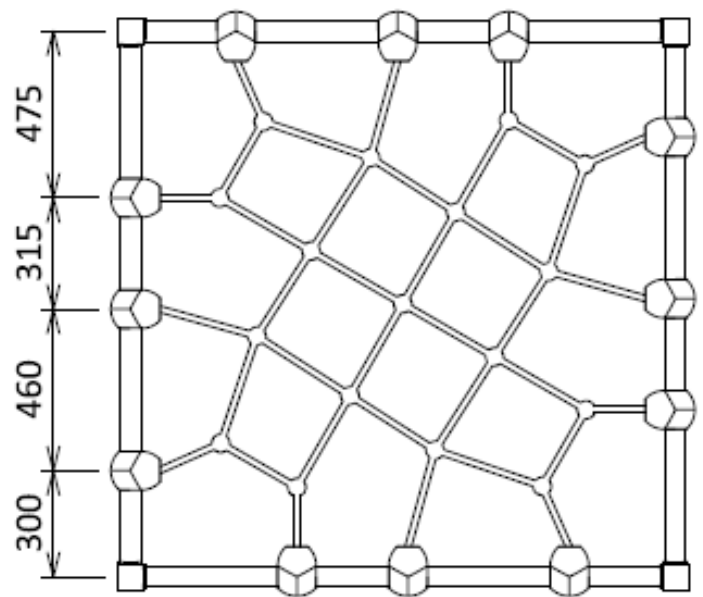

Inclined Webs

Locate the correct position to mark and dig the hole in the ground for the two legs. Attach legs to uprights using 20mm tri-lobes.

Attach the top of the rope ends to housings with M8x28 post Torx and housings to platforms with square washer and 17mm tri-lobes and standard flange connections to the middle upright. Standard orbit clamp connection of the horizontal bar to legs.

Tension the ropes as required by gently sliding the clamps slightly along the legs and then secure them in place using a tech screw on both sides of each clamp into the legs.

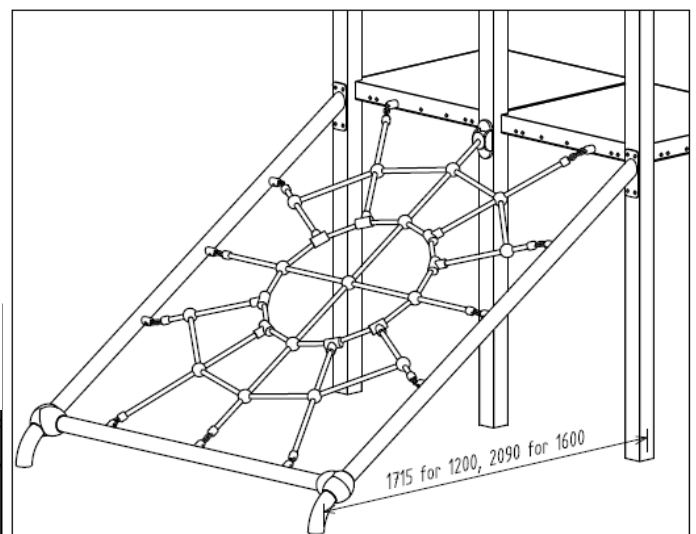
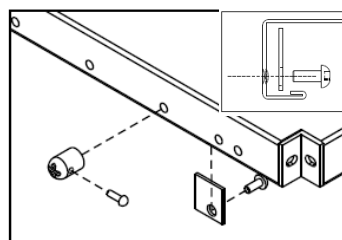

Ladder Rung

Every rung is attached to uprights with a standard flange connection.

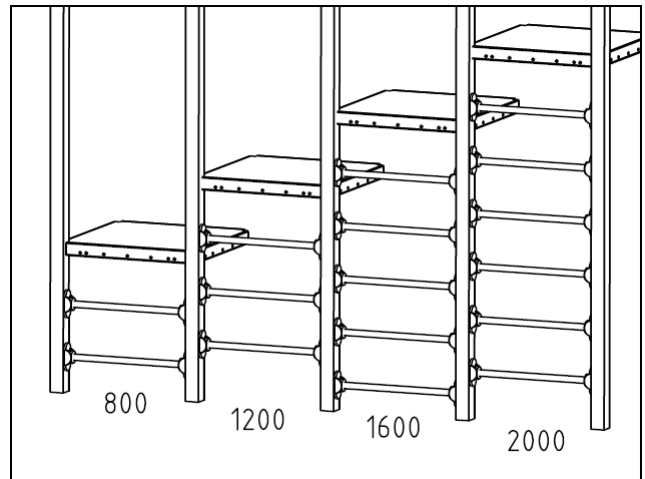

Ladder Wave

Locate the correct position to mark and dig the holes in the ground and attach them to the platform using 17mm tri-lobes and T-nuts.

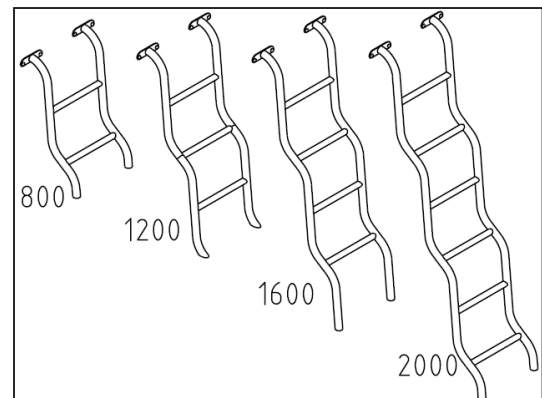
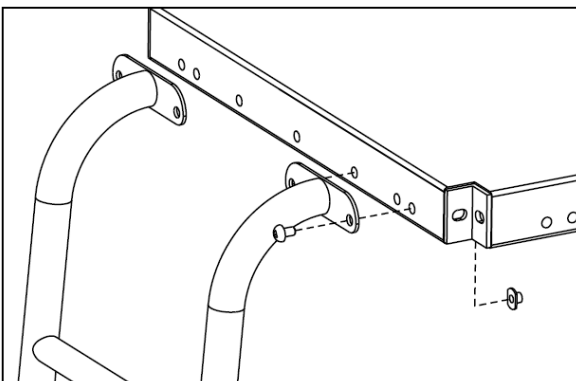

Overhead Items

(Monkey Bars, Wave Bars, Roman Rings, Challenge Rails and Hang 'n' Glides, Monkey Spin 3P, Hang 'n' Glide 7p, Monkey Bar 'S' 2P and 3P, Tarzan Maze 3P, Chin Up Bar)

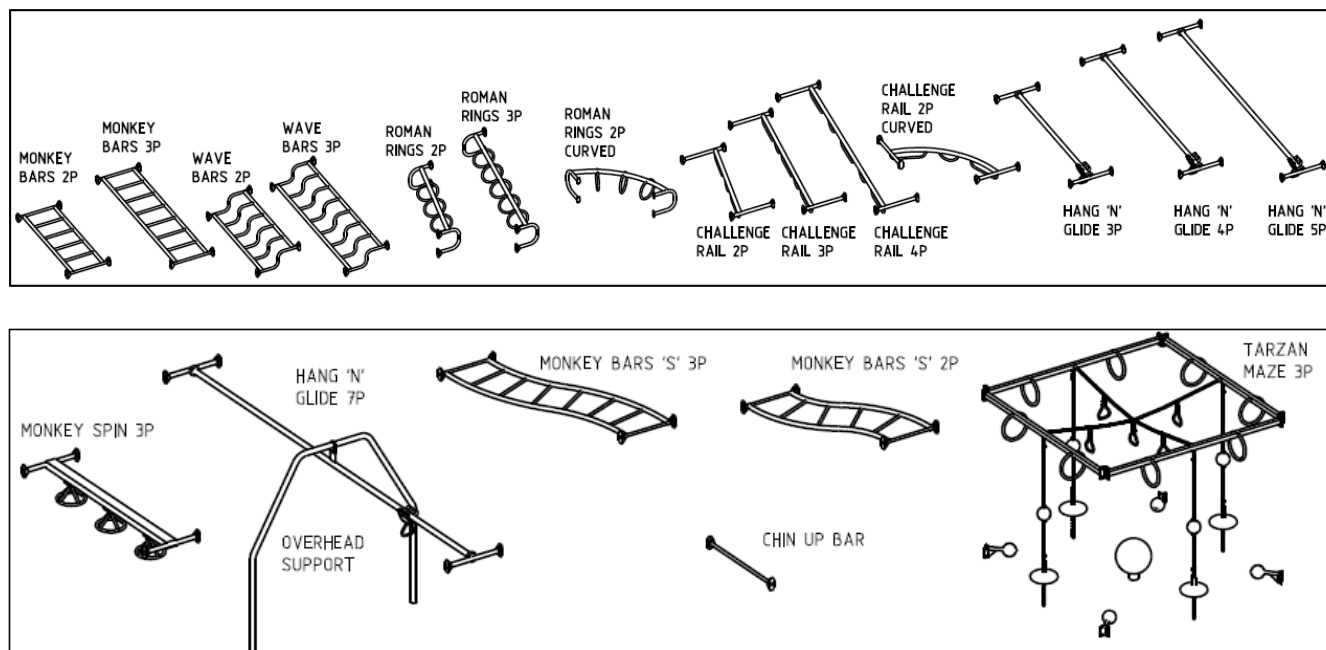

Position the overhead item on the ground with the first end level with the uprights it will connect to. Mark the spot for the next two uprights, dig the holes and insert the uprights to the correct height. Attach the flanges to the top bar (as detailed in “flanges” on page 5 of this manual), then attach to the uprights using 20mm tri-lobes. Ensure that the bolts are tightened, the uprights vertical and the overhead item horizontal (except in the case of inclined and arched items). After attaching any connecting rungs, steps or platforms, concrete the uprights into the ground.

Roman Rings 2, 3P and Curved are attached on 2 uprights only with 2 flanges on each upright. The curved one has steel flanges.

Hang 'n' Glides also require a platform buffer on the leading edge of both opposing platforms (see Platform Buffers on page 18).

Hang 'n' Glide 7P has support attached in the middle with Trilobes 25 and T nuts.

Tarzan Maze 3P has plates to attach to uprights. The ropes and chains are attached to top bars with bolts 8x28 post Torx.

Concrete pommel chains in the ground. Standard Orb concrete in the centre.

Panels (Over platform)

Binocular / Telescope Panel

Attach the binocular or telescope to the plate and Aly boards with Trilobes 17.

Cover the hole on the bracket with Trilobe 17 with Security Cap+Nut.

The rest is assembled the same as Slat Panel.

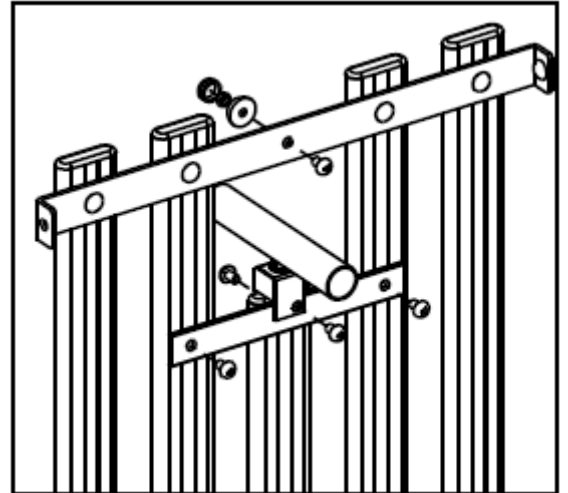

Slat Panel

Attach support bracket to uprights with tri-lobes 20mm, then tri-lobes 17mm for the Aly boards and tri-lobes 17mm with Cap Nuts Di Cast for timber boards.

Use the same fittings for platform connection.

Slat Filler

Position plates as shown and attach to uprights with tri-lobes 20mm.

For Aly boards, use tri-lobes 20mm and for timber, use tri-lobes 17mm with Cap Nuts Di Cast.

Slat Fillers 800 and over have vertical bars and only 2 boards are attached to the uprights.

Boards are attached to vertical bars with Trilobes 50 – Aly boards and Trilobes 40 – timber boards. Aly boards with bolts from vertical bars, and timber from the board side.

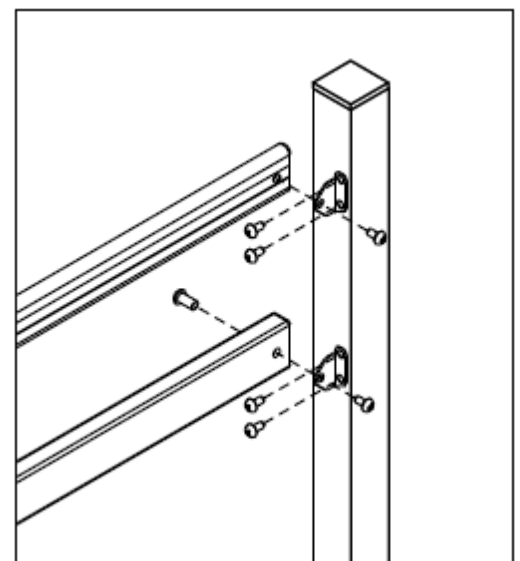
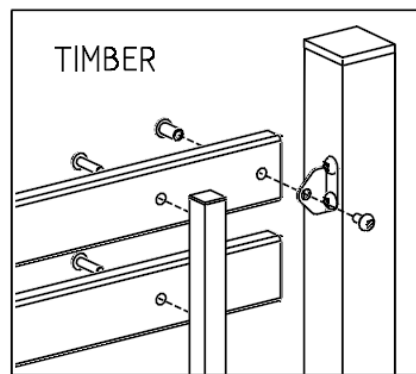
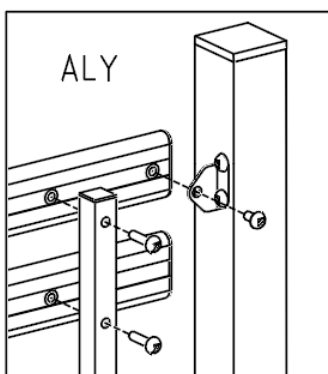
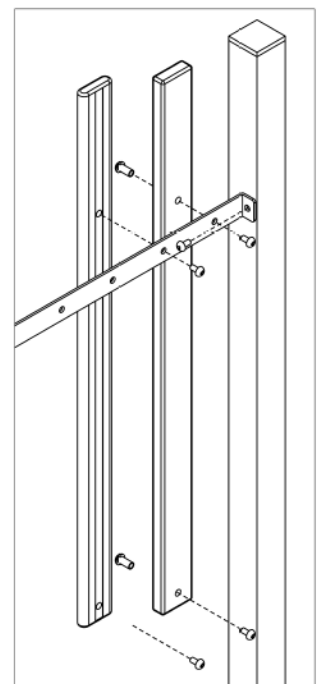

Slat Infill (800, 1200, 1600 and 2000)

Attach support bracket to uprights with tri-lobes 20mm, then tri-lobes 17mm for the Ply boards and tri-lobes 17mm with Cap Nuts Di Cast for timber boards.

The 800 and 1200 infills have 2 support brackets, 1600 and 2000 have 3.

These items are not attached to platforms and can be over and under.

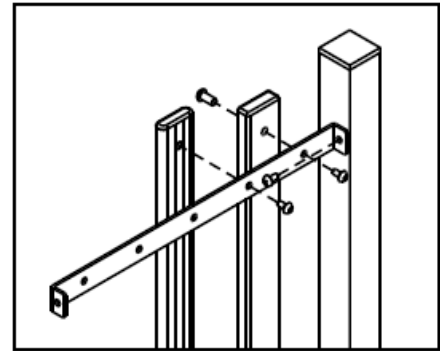

Offset Panel

Attach the lower part to the platform with tri-lobes 20mm and T Nuts and to uprights with bracket and tri-lobes 20mm (upright) and bolts 10x25 C/H, security caps and nuts (panel).

Attach the upper part to support with bolts 10x25 C/H, security caps and nuts. Attach support to uprights with tri-lobes 20mm.

Square holes of the top and low panels should match. Use a joining panel to bolt parts together using bolts 10x30 C/H, security caps and nuts.

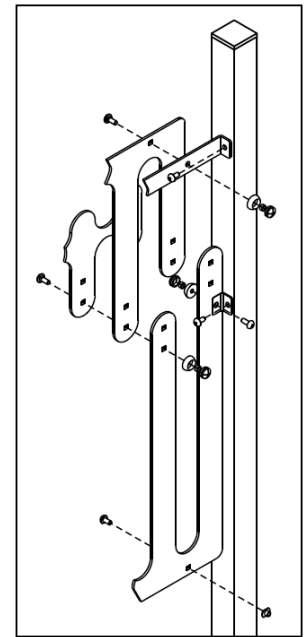

Entrance Tunnel Panel

Attach bar to uprights with tri-lobes 20mm. Flange panel to the platform with tri-lobes 20mm and T nuts.

The top panel and the top of the flange panel are attached to the bar with tri-lobes 20mm.

Both panels are joined with bolts 10x25 C/H, security caps and nuts.

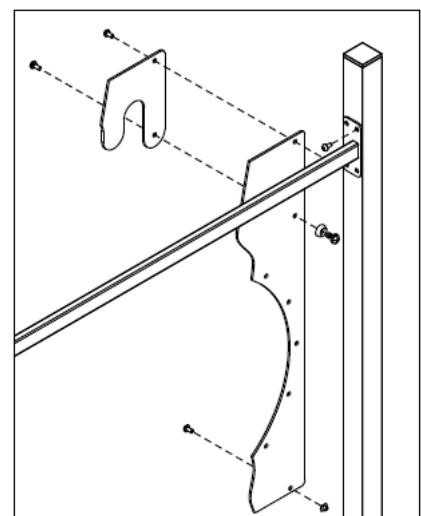

Entrance Double Slide Panel

2 parts of the frame are joined by Trilobe 40. Attach 3 flanges of the frame to uprights with Trilobes 17. The lower part of the frame goes to the platform with Trilobe 17 from the platform side.

The panel is attached to the platform with 2 Trilobes 17 and 2 T nuts. The upper part is attached to the frame with 2 Bolts 25 C/H, 2 Trilobes 50 and 4 Security Caps +Nuts.

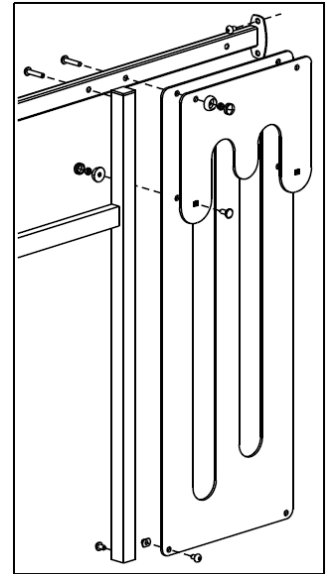

Vertical Panel

Attach the lower part to the platform with tri-lobes 20mm and T Nuts and to uprights with bracket and tri-lobes 20mm (upright) and bolts 10x25 C/H, security caps and nuts (panel).

Attach both supports to uprights with tri-lobes 20mm.

Attach the upper part to support with bolts 10x25 C/H, security caps and nuts

Square holes of the top and low panels should match. Use a joining panel to bolt parts together using bolts 10x30 C/H (support) and 10x25 C/H, security caps and nuts.

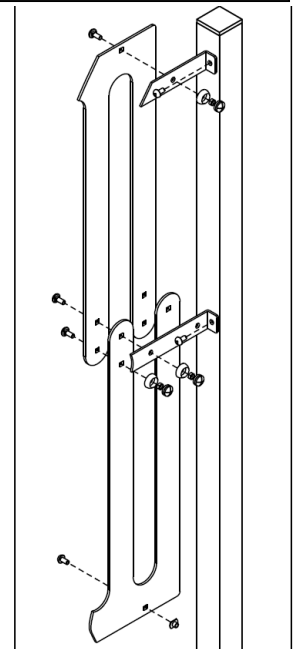

Mesh Panel

Attach the frame to uprights with bolts 10x35 post Torx.

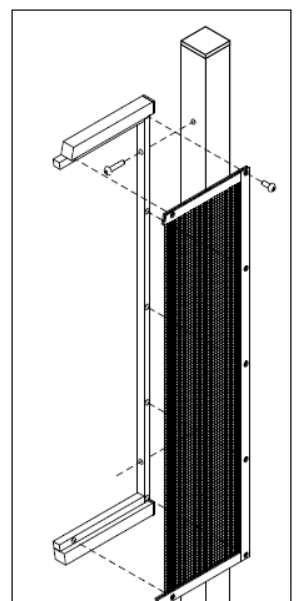

Rock Face 1200 / 1600 / 2000 / 240

Rock Grips, Panel Stripes and Handgrip Stripes are pre-assembled to the main panels.

Attach flanges and brackets to uprights with Trilobes 20.

Attach the top end of the panel to the platform and brackets with Trilobes 25 and T nuts.

Panels to flanges with Trilobes 25.

Rock Face 2400 has 2 panels joined and are attached to the bracket with Trilobes 40 and T nuts.

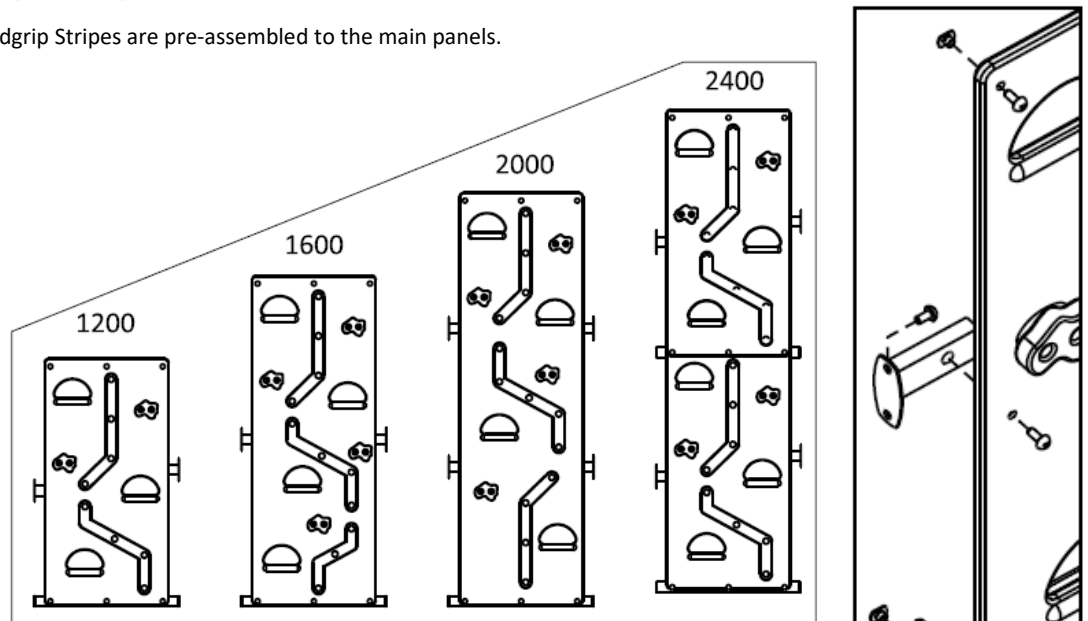

Rock Panel and Safety Panel (Under and Over)

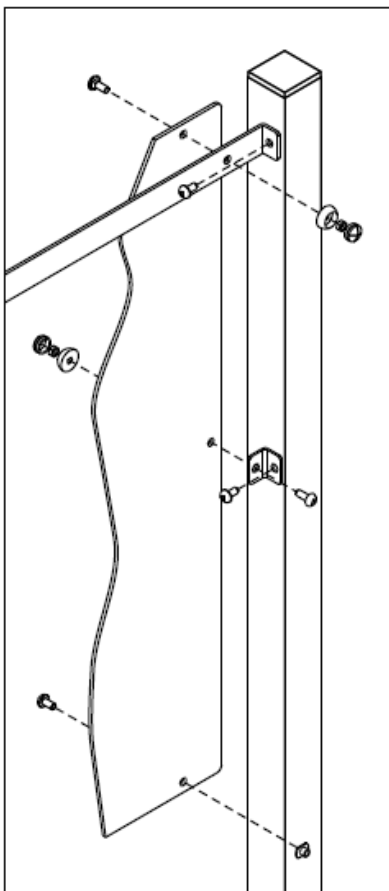

Attach the panel to the platform with tri-lobes 20mm and T Nuts.

Attach brackets (B2) to central panel holes with tri-lobes 25mm (back), security caps and nuts (front).

Attach panel support bracket to the back face of the panel with bolts 10x25 C/H (front) and security caps and nuts (back).

Attach the panel to uprights with tri-lobes 20mm.

When there is another 400 or 1200 panel use bolts 10x30 C/H instead and keep the stripes in line, the upper panel will sit over the lower panel as per the image.

When joining together – support bracket, 2 panels and stripe, use bolt C/H 10x40.

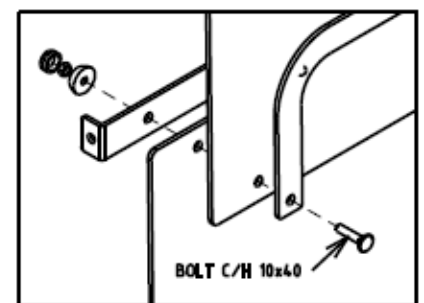
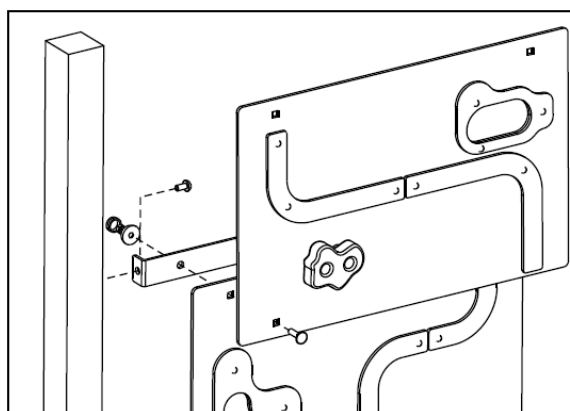

Clock, Kaleidoscope, Port Hole, Observation and Xylophone Panels

Attach to the platform with tri-lobes 17mm and T Nuts and to uprights with bracket and tri-lobes 17mm (upright) and bolts 10x30 C/H, security caps and nuts (panel, using one of the flange holes).

Attach the upper part to support with bolts 10x25 C/H, security caps and nuts. Attach support to uprights with tri-lobes 20mm.

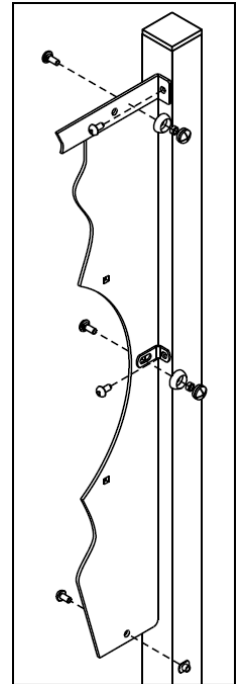

Panels (Under platform)

Toddler Panels

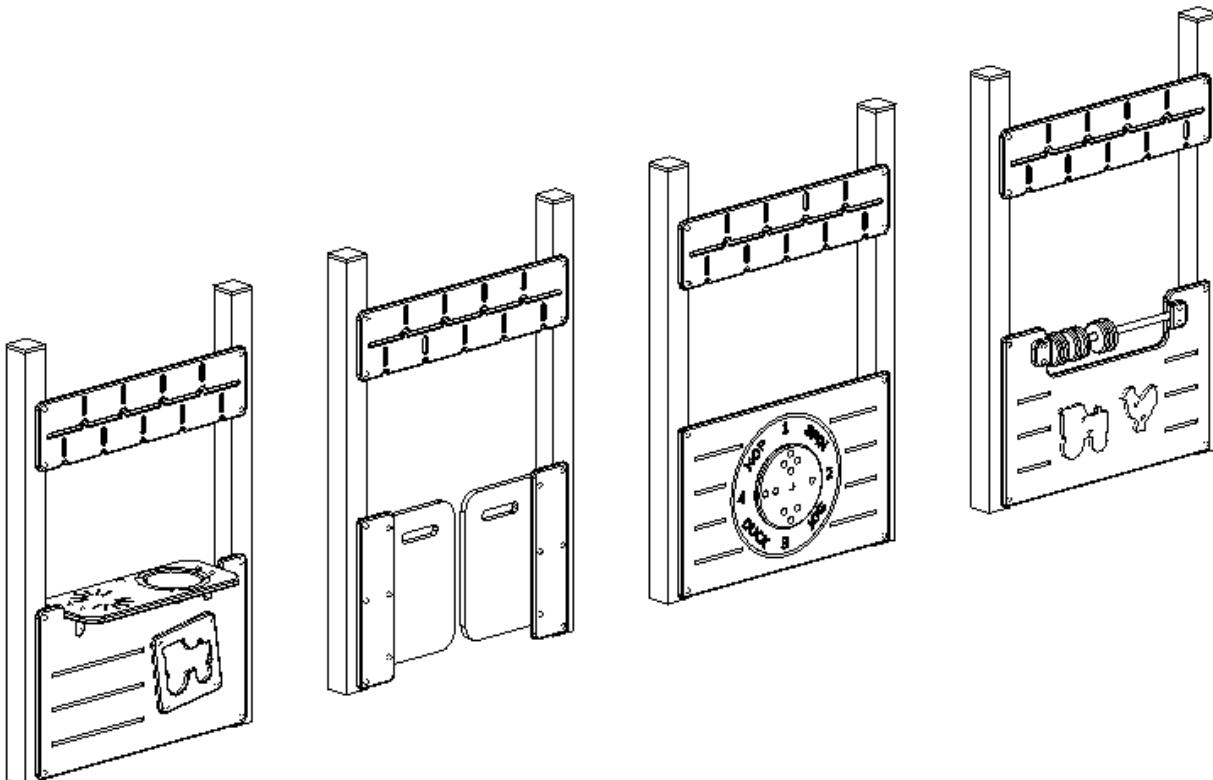

Attach the “Toddler Roof Single Panel” (2616, 2617, 2618, 2619) and the “Toddler Panel Single Counter” (2620-Red, Light Blue, Green, Teal) to the face of the uprights using 10x30 Torx Bolts.

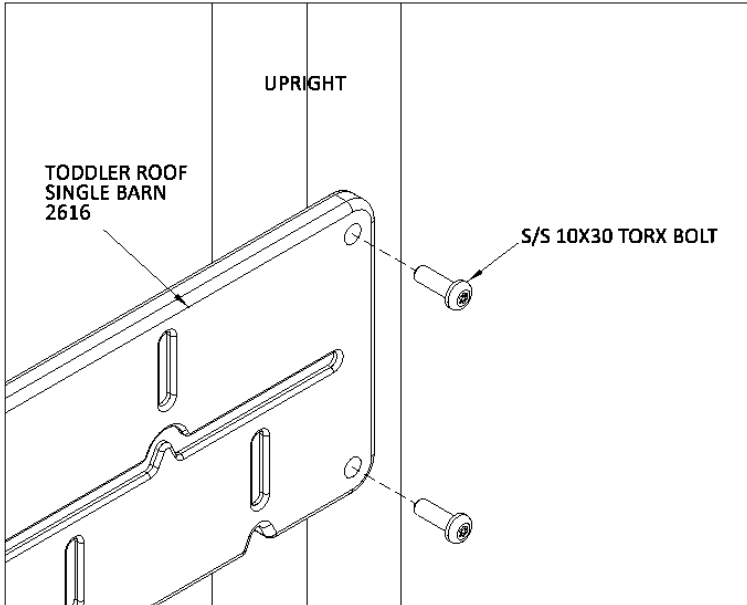

Attach the various “Toddler Tiles” (2627, 2628, 2629, 2630) to the “Toddler Panel Single Counter” (2620) using 10x30 Torx Bolts and 10x20 Cap Nuts.

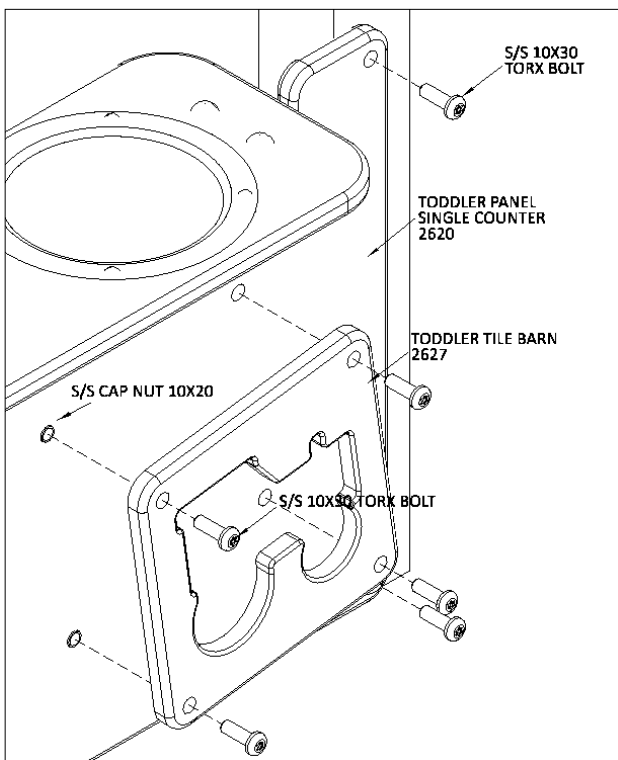

Attach the Acrylic Bowl to the “Toddler Counter” (2606) using an M6 Cap Nut from the top and a 6x20 post torx bolt and M6 Washer.

NOTE 4x 9mmD holes need to be drilled in the Acrylic Bowl, use the countertop as a drilling template.

Attach 4x Xylophone Brackets to the “Toddler Panel Single Counter” (2620) using a 10x20 Cap Nut and a 10x20 Torx Bolt (x4). Place the “Toddler Counter” in the Cut-out on top of the “Toddler Panel Single Counter”, aligning the counter holes with the Xylophone brackets underneath. Attach with 10x20 Torx Bolts from the top and Cap Nuts from the bottom.

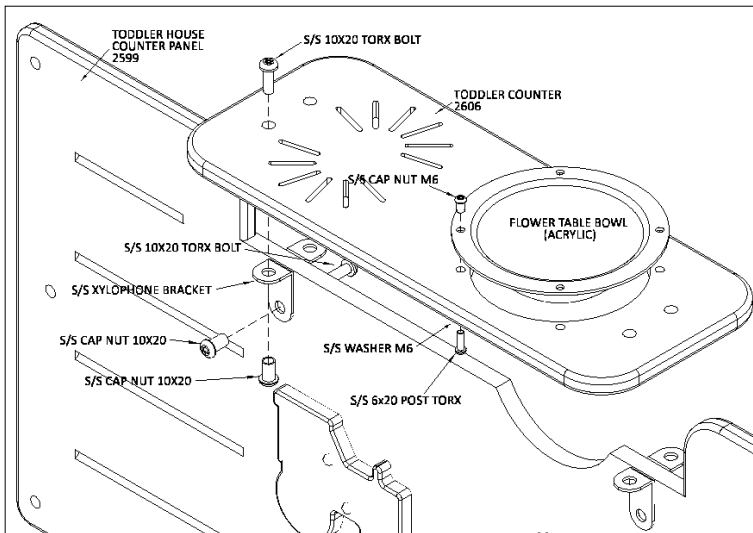

Attach the M10 eye nut to the underside of the “Toddler Counter” using a 10x30 Torx Bolt and security cap topside. The “Water Table Rope/Cable” attaches to the M10 Eye Nut and “Toddler Scoop” (2614) using an 8mm D-Shackle at both ends. Cut the tab off the D-shackle and grind back smooth.

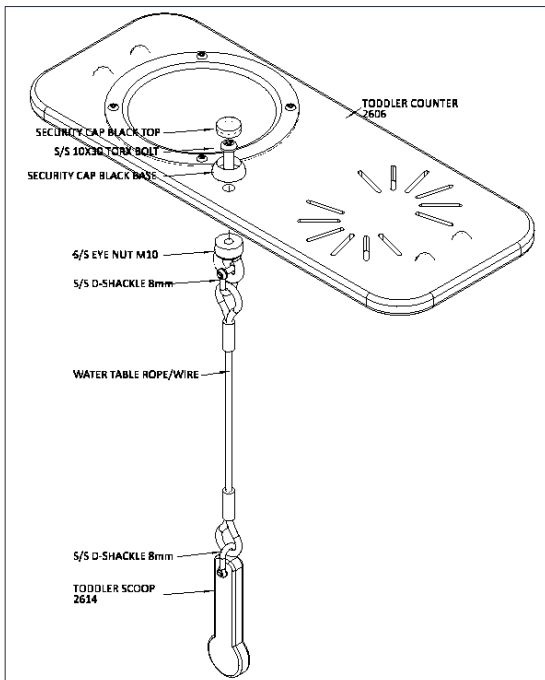

Attach the “Toddler Rubber Single Doors” (2612) to the “Toddler Panel Single Doors” (2621) using a 10x20 Cap Nut through the front of the panel and a 10x20 Torx Bolt and S/S 50mm washer on the back of the rubber door (x3). Apply Loctite.

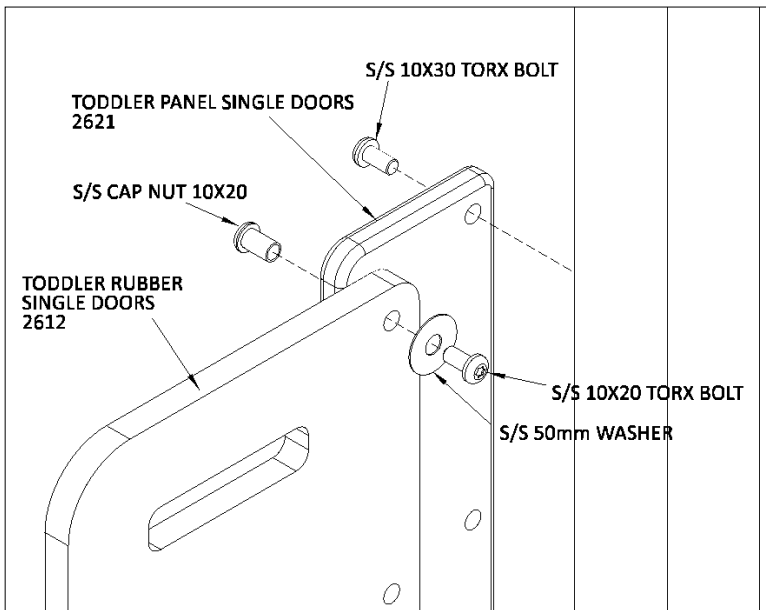

Attach the “Toddler Activity Disc” (2604) on the outside of the “Toddler Panel Single Activity” panel (2622) using a 10x30 Post Torx Bolt, M10 Washer, an M12 Washer in between the disc and the panel and a 10x20 Cap Nut and M12 Washer on the rear of the panel.

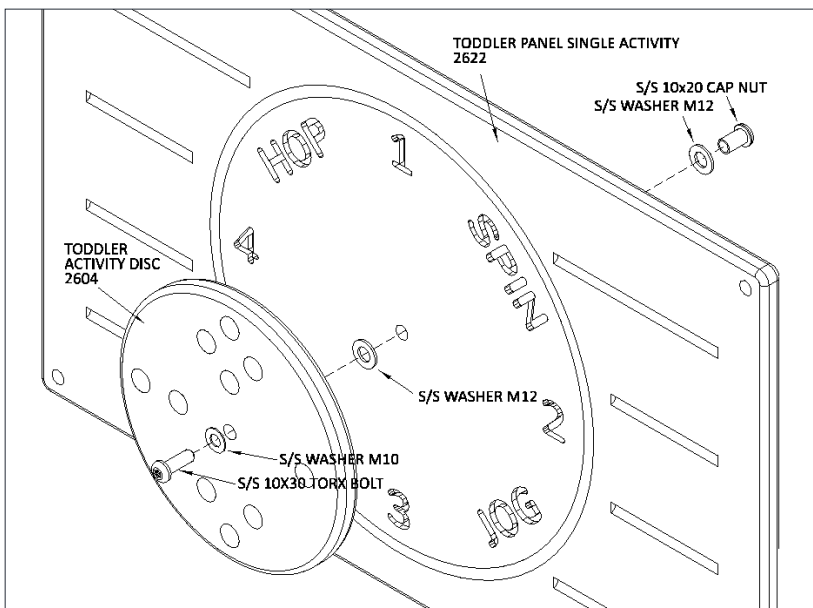

Insert the “Toddler Abacus Rings” (2603) onto the “Toddler Abacus Bar” (2631). Place the Abacus Bar ends into the channels on the “Toddler Panel Single Abacus” (2623), place the HDPE clamping panels on the outside. Attach two 10x20 Cap Nuts and two 10x30 Torx Bolts at both ends of the bar.

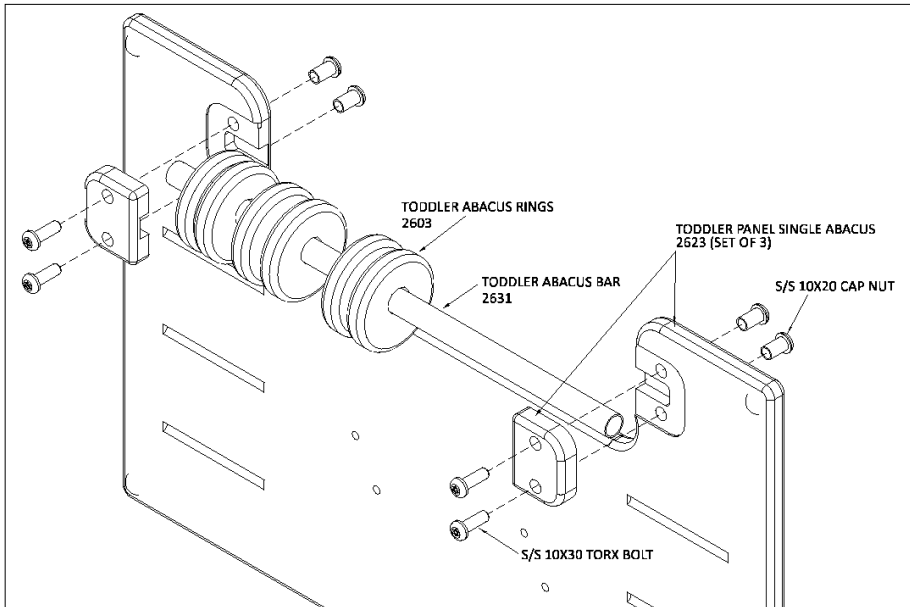

Attach the shape cut-outs (2607, 2608, 2609 & 2610) to the “Toddler Panel Single Abacus” (2623) using 2x M6 Cap Nut on the shape front, 2x 6x30 Post Torx Bolts and M6 Washers through the panel on the back.

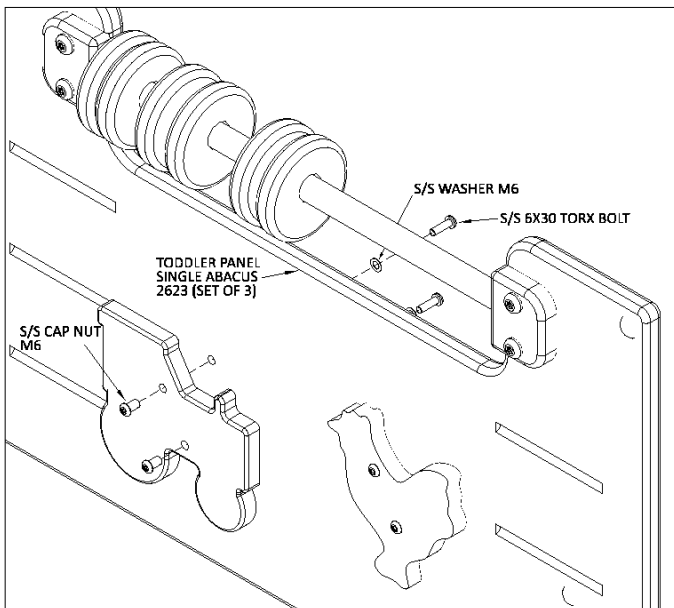

Slat Panel

Attach support bracket to uprights with tri-lobes 20mm, then tri-lobes 17mm for the Aly boards and tri-lobes 17mm with Cap Nuts Di Cast for timber boards. Use the same fittings for the lower bracket.

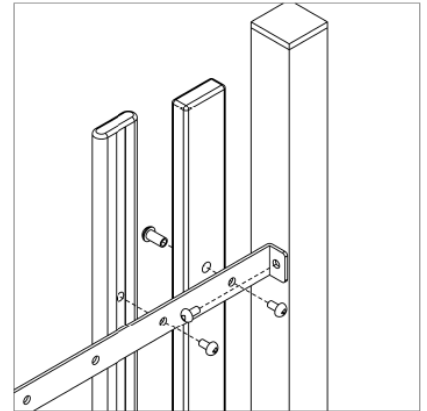

Mesh Panel

Attach the frame to uprights with bolts 10x35 post Torx.

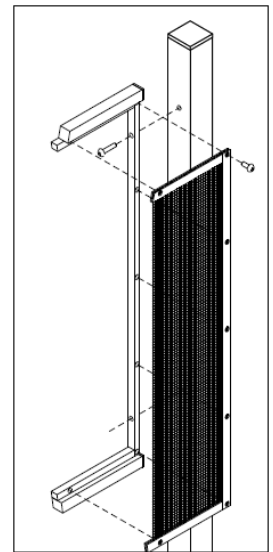

Counting Panel

Arrange the balls with colours according to the job's paperwork. Use standard pipe and plastic flange connection.

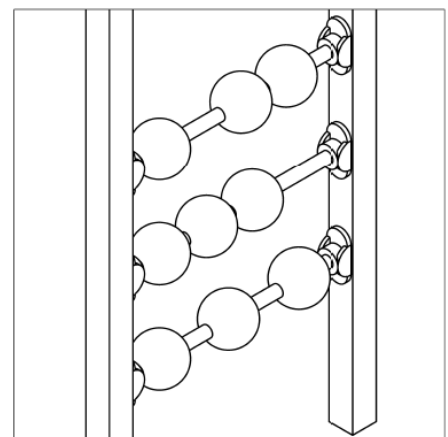

Squeeze Panel

Attach bars to uprights with tri-lobes 17mm.

Standard chain to housing connection.

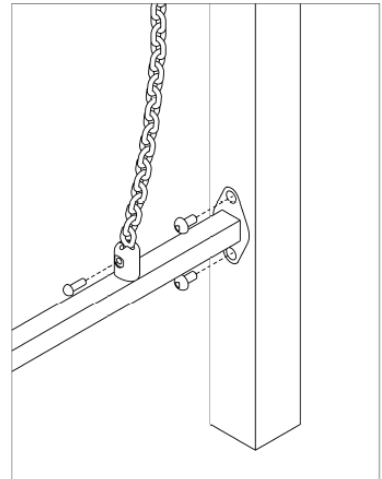

Clock, Kaleidoscope, Port Hole, Observation and Xylophone Panels

Attach to the platform with tri-lobes 17mm and T Nuts and to uprights with bracket and tri-lobes 17mm (upright) and bolts 10x30 C/H, security caps and nuts (panel, using one of the flange holes).

Attach the lower part to support with bolts 10x25 C/H, security caps and nuts. Attach support to uprights with tri-lobes 20mm.

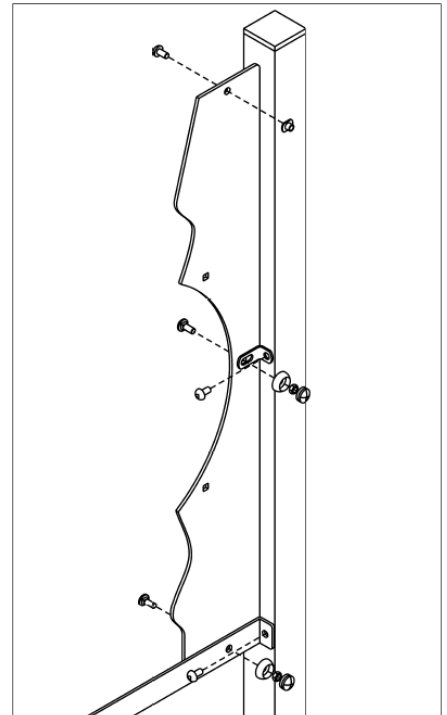

Slat Counter

Use tri-lobes 20mm to attach support brackets to uprights and for the Aly boards, bracket and counter. Same fittings for the boards and lower bracket.

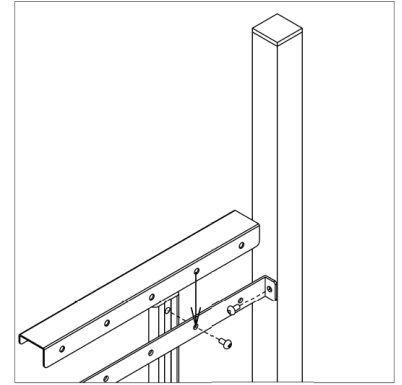

Spiral Abacus

Attach plate to upright using tri-lobes 20mm.

Standard flange connection.

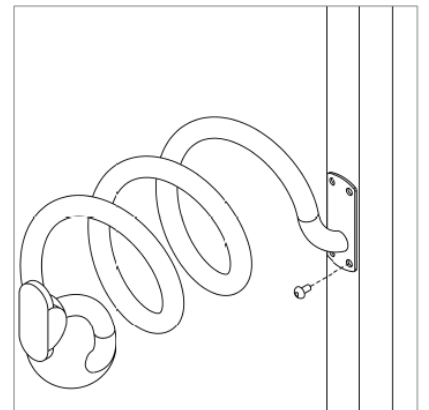

Platform Buffers

Fasten the buffer to the platform face. Insert the platform buffer plate inside the rubber buffer, lining up the holes in the plate with the holes in the outside face of the buffer. Insert a 20mm tri-lobe and washer into each of the 4 holes as shown then fasten to the platform face with a T-nut on the inside of the platform.

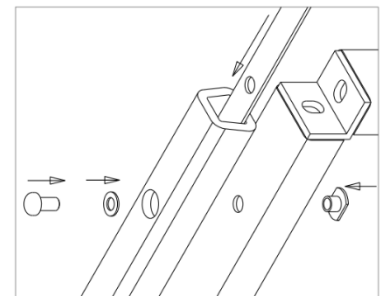

Pod Crossing

All parts with flanges are attached with a standard flange connection.

Position the top bar on the ground with the first end level with the uprights it will connect to. Mark the spot for the next two uprights. Dig the holes and insert the uprights to the correct height. Attach 4 flanges to the top, then lift the top bar into place and bolt onto the uprights. Attach pommels to poles using 17mm tri-lobes.

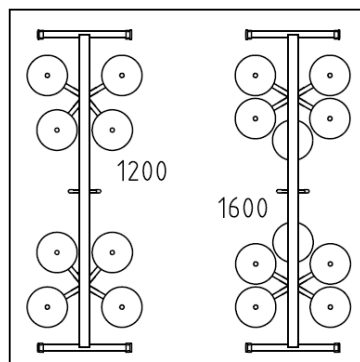

Dig the hole (approximately 600mm below the finished ground level), and place and rotate the poles into position as shown. Attach the flanges to the pole's top, then attach the poles and rope handle to the top bar. Place a brick below the poles to provide additional support and stability (poles should not pull down the top bar). Ensure the poles are vertical then concrete into the ground – extra concrete is required for soft soil.

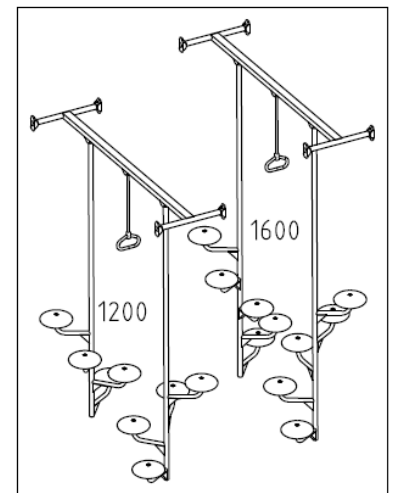

Poles

(Firepole, Ladder Pole, Ladder Reach, S Pole, Step-Up Pole, Helix Climber, Pommel Climber)

Attach the fire pole top to the pole using a 'tap tight' tri-lobe (the top is common to all poles). Lift the pole into its approximate place to determine the position of the hole in the ground. Dig a hole (approximately 600mm below finished ground level) and place the pole into position. Standard flange connection. It is advisable to place a brick or a block of wood below the pole to provide additional stability. Ensure the pole is vertical then concrete into the ground.

(The plastic steps on the Step-up Pole should be attached to each rail using 17mm tri-lobes.)

Pommel Climber has 4 flange frames and the chain is attached to it with Bolt M8x28 Post Torx.

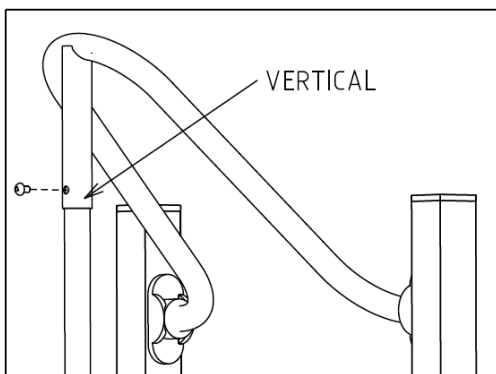
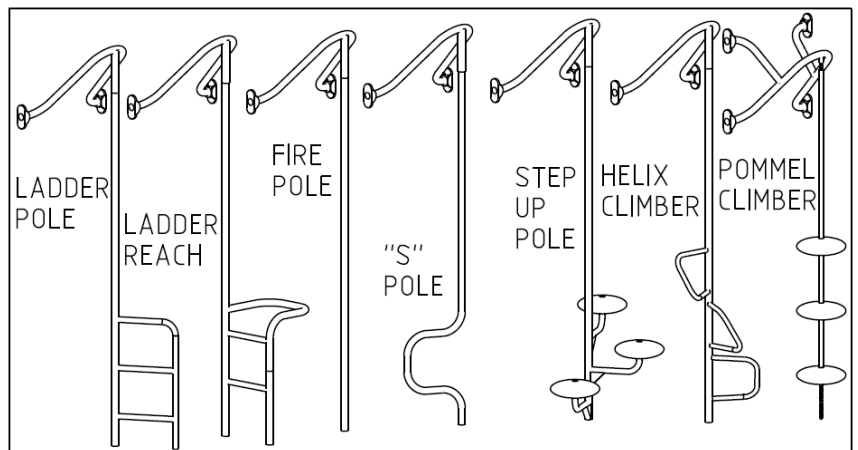

Pommel Joiners / Pommel Walkers

Position the top bar on the ground with the first end level with the uprights it will connect to. Mark the spot for the next two uprights. Dig the holes and insert the uprights to the correct height. Attach the suspended chains to the top bar (as detailed under "chain housing connections" on page 5 of this manual). Lift the top bar into place and bolt it onto the uprights. All parts with flanges are attached with a standard flange connection. Attach chain ends to rails with 8x28 post Torx. Dig a hole directly below each suspended chain and pommel. Allow the chains to hang into the holes, ensuring that

they are taut. (If rubber surfacing is to be used, a pommel/chain anchor is supplied. The chain should be cut just above finished ground level and the anchor connected using an 'S' hook.) After ensuring that the bolts are tightened and the uprights vertical, concrete the uprights and the lower end of the chains into the ground.

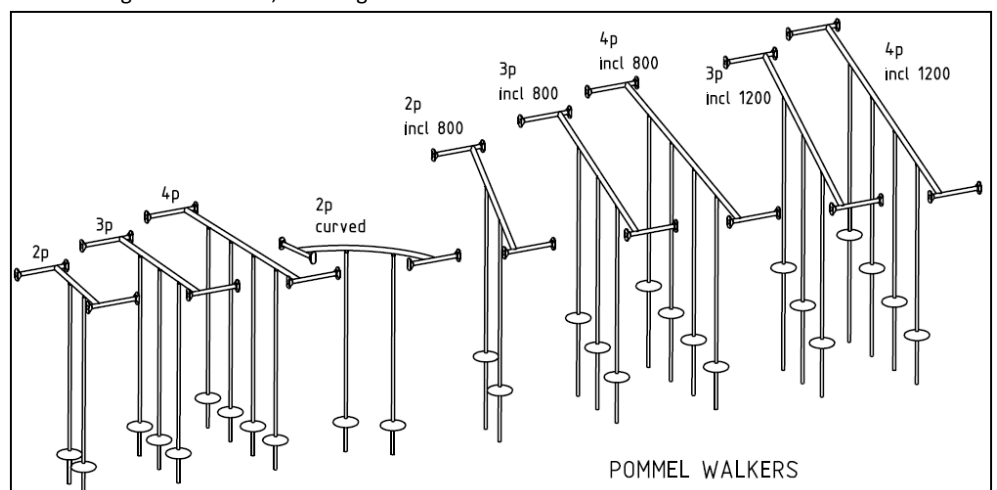
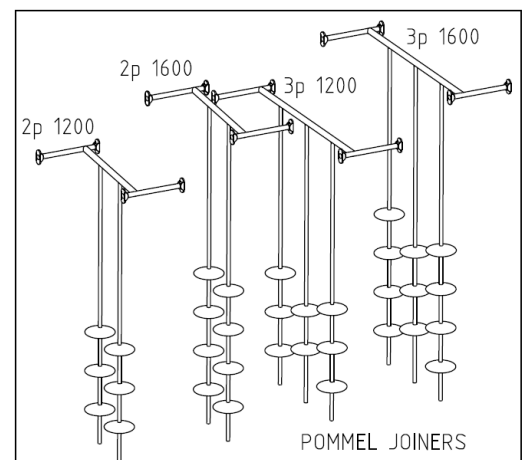

Rock Joiners

Position the panel in place between the two platforms. Attach to platforms, using 17mm tri-lobes from the panel side and T-nuts from the platform side.

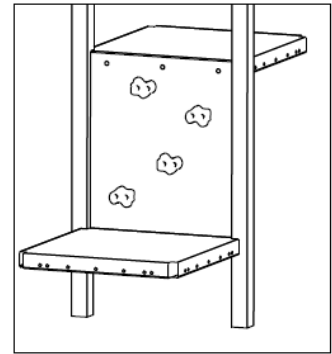

Roller Bed 2p

Join the 8 ball sets to the side rails with 25mm tri-lobes, keeping the ball colors as per job image. Using the side rails as a guide, determine the distance between uprights, and dig holes for the uprights. Bolt side rails to uprights with 25mm tri-lobes. (For exact distances see “Determining Distances between Uprights” at the front of this manual.) Place the uprights in the holes and ensure that their depth is correct. Attach the chain rungs to the uprights using 25mm tri-lobes. Remove chain links if needed to have the chain as tight as possible with standard chain-to housings bolting. Attach the platforms or end frame joiners to the uprights. After ensuring that the uprights are vertical, concrete them into the ground.

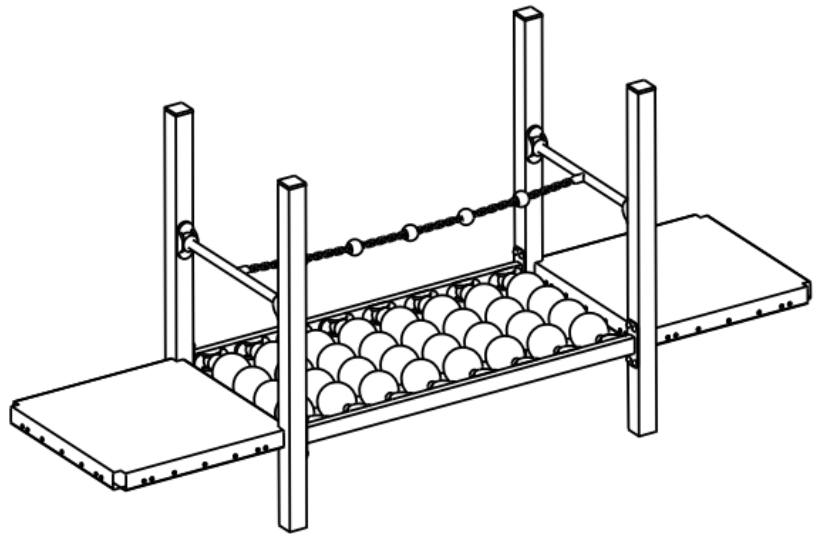

Rope Climber

Attach the top of rope ends to housings with 8x28 post Torx and housings to platform with square washer and 17mm tri-lobes.

Attach the low ends of the net to anchor using 'S' Hooks as shown. Pull the rope net away from the platform until 'S' hooks come to finished ground level. The rope ends should terminate just above the finished ground level. Ropes are twisted and should look parallel to uprights from the front view. Dig a trench wide enough to allow the chain anchor at the base of the net to continue into the ground at the same angle. Place the anchor in the trench to a depth of approximately 500mm then concrete.

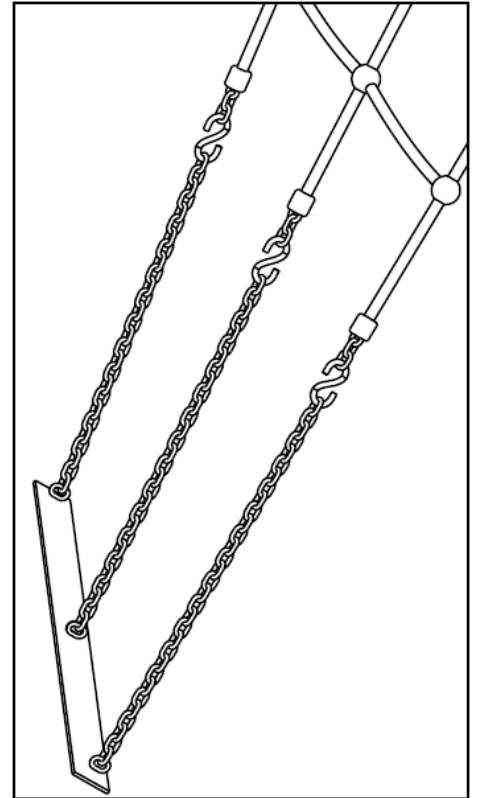
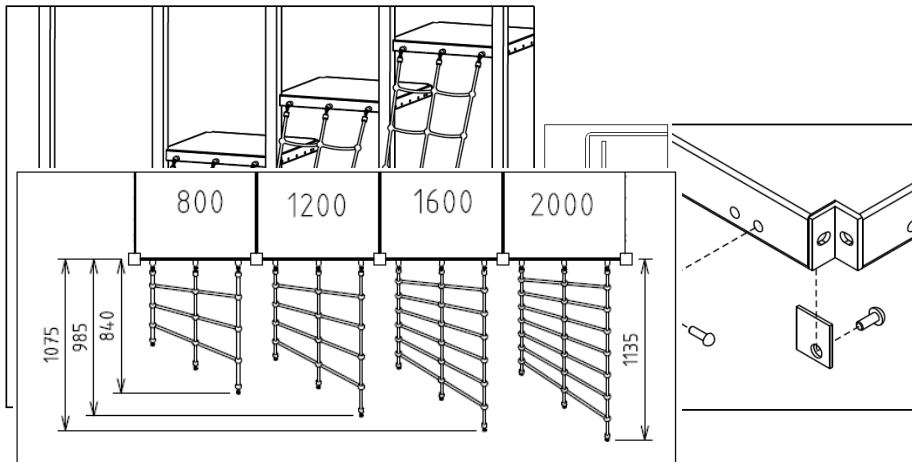

Rope / Scatter / Plank Walk / Plank Walk (Over 2M) / Ravine Bridge joiners

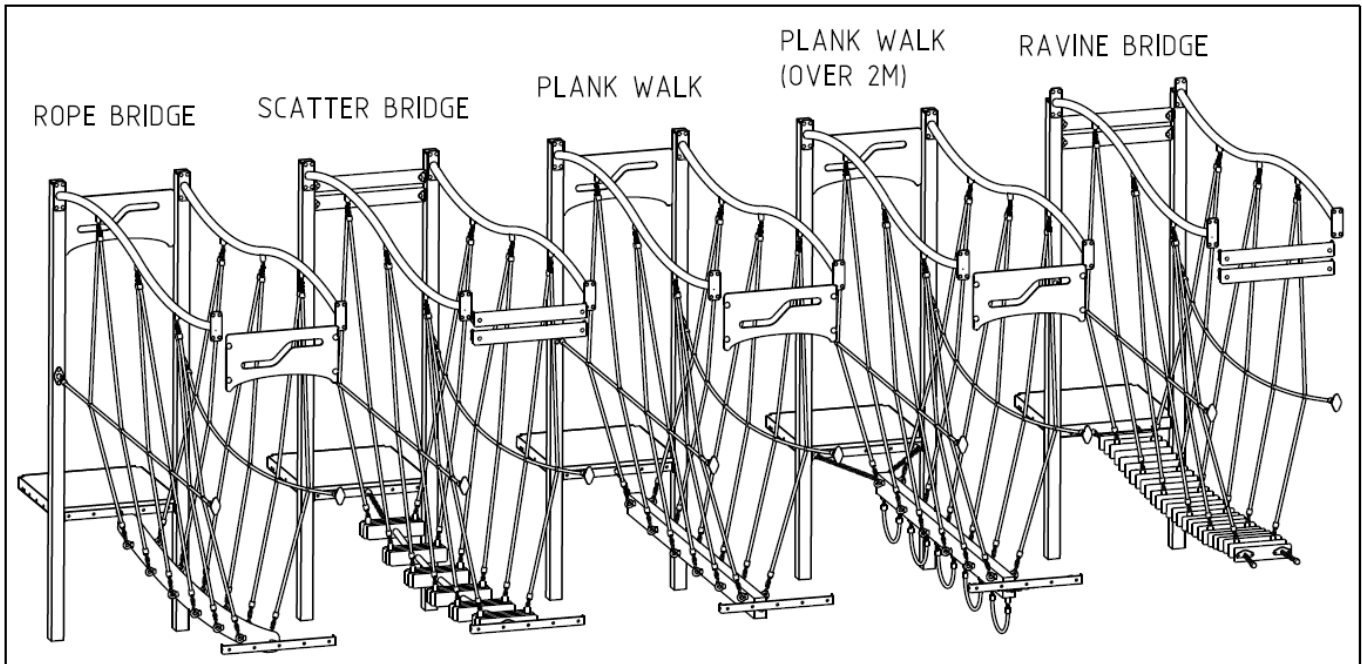

Position the top bars on the ground with the first end level with the uprights it will connect to. Mark the spot for the next two uprights. Dig the holes and insert the uprights to the correct height.

All bridge joiners have the same top bars attached to uprights with 20mm tri-lobes and mid-height steel flanges to uprights with 17mm tri-lobes. All rope nets, walks and chains are preassembled and to be attached to top bars with bolts M8x28 post Torx.

Walk's end chains with housings are attached to platforms through support brackets with 20mm tri-lobes from the platform side and brackets to uprights with 20mm tri-lobes (exclusion is Ravine walk - 20mm tri-lobes from platform side to chain housings). Plank Walk (over 2m) bridge has 2 chains, on each side.

Rope, Plank Walk and Plank Walk (over 2m) bridge joiners have aluminium entrance/exit panels attached to B1 panel brackets with 17mm tri-lobes, security caps and nuts and then to uprights with 17mm tri-lobes.

Scatter and Ravine bridge joiners have timber entrance/exit boards. Attach plates to boards with tri-lobes 17mm with Cap Nuts Di Cast and attach to uprights with tri-lobes 20mm.

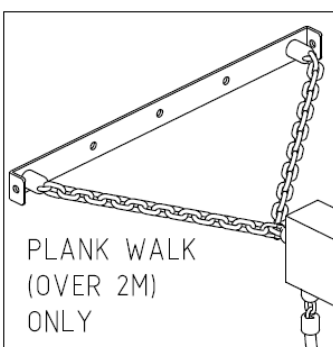
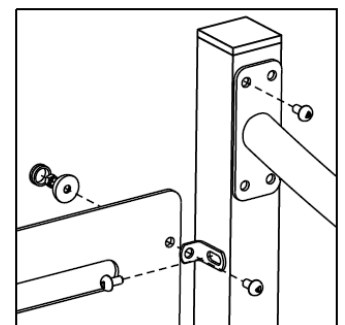
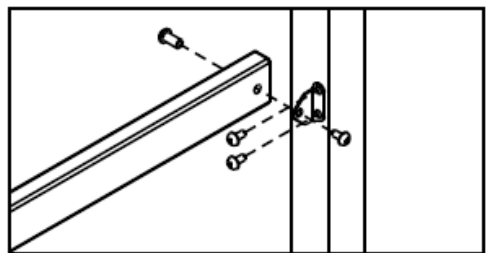

IMPORTANT – extra chain links have been added to allow for adjusting the finished item by removing links as needed.

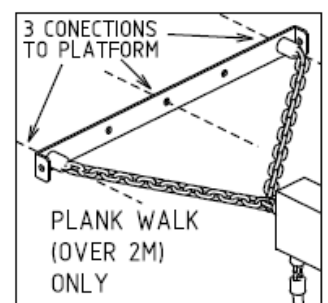
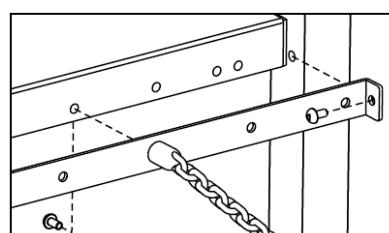

Rope Seat

Attach steel flanges to the drillings on the uprights using 17mm tri-lobes.

Join rope ends to flanges with S/S bolts 8x25 Post Torx.

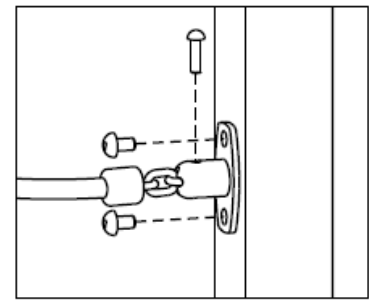
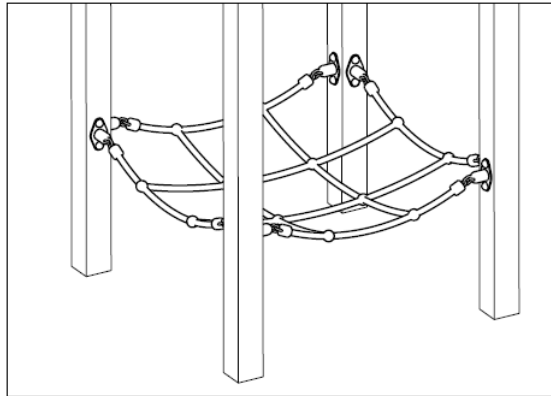

Rope Twist

Attach the Orbit clamps to the ropes and to the top diagonal bar – standard connection (do not screw orbit clamps to the top bar yet). Use a standard flange connection to attach the short top rails to uprights and use Trilobes 20 for the diagonal top bar. Attach the steel flanges to the ends of the chains using St Bolt 8x28 Pst Trx. Attach steel flanges to uprights with Trilobes 17. Stretch the Orbit clamps on the top bar at an equal distance, avoiding loose ropes and screw them to the top bar.

Option 2P for Max 2000 has 2 pommel steps along the bottom chain, at an equal distance between the legs of the diagonal uprights. See “Stepper Single 200 (elevate)” in this manual to install the steps.

Option 3P for Max 2000 has 2 pommel steps and an Orb along the bottom chain, at an equal distance of the legs between diagonal uprights. See “Stepper Single 200 (elevate)” in this manual to install the steps and “Orb Low” from the “Installation Manual - Freestanding Static” to install the Orb.

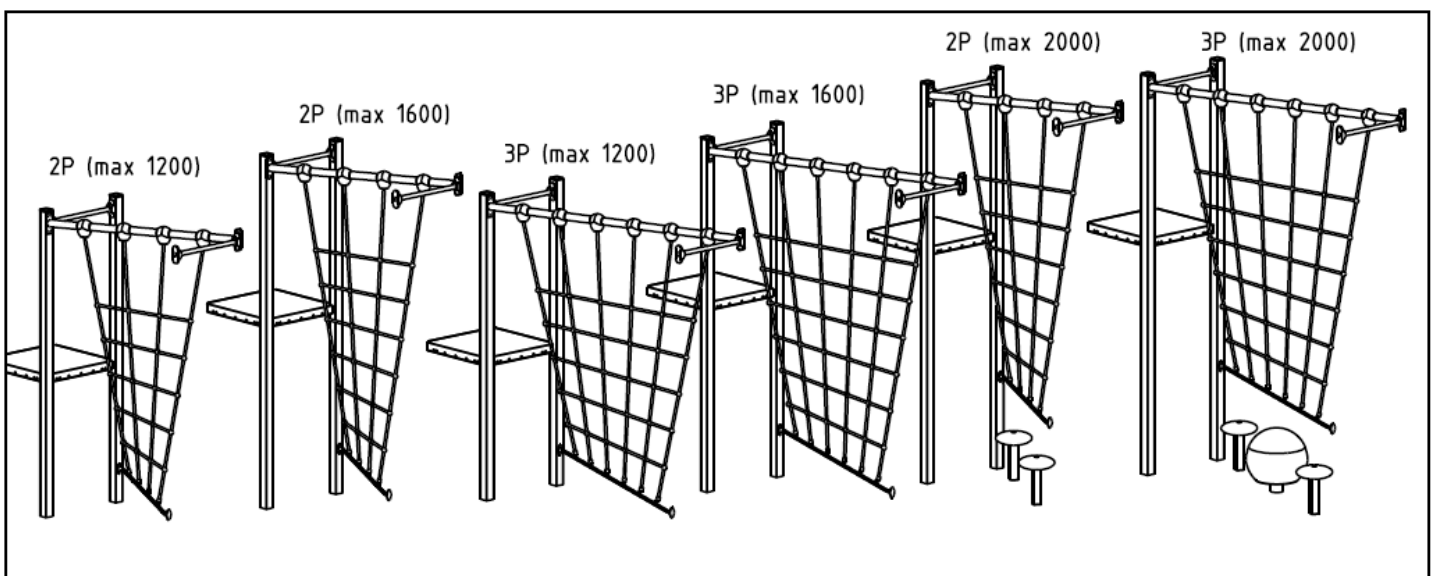

Roofs

Raise the roof over the uprights and lower down, ensuring the orientation matches the plan.

Curved Roof

Use a 10x60 Post Torx bolt and 2x Plastic Saddle Spacers to attach the roof to each upright.

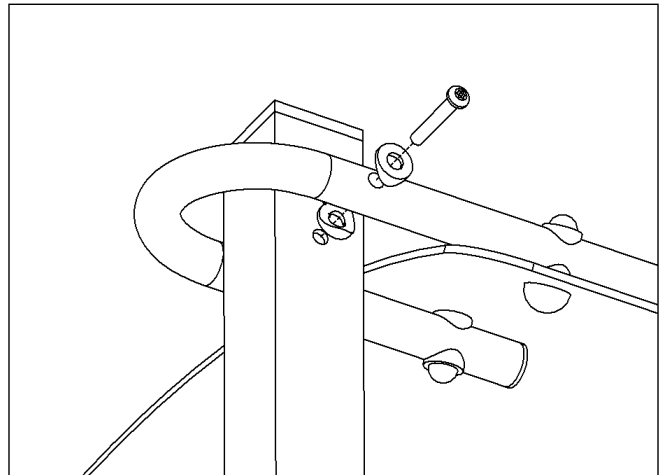

Pitch Roof

First, bolt the brackets to uprights, with a welded nut on high, using 17mm tri-lobes. Tilt B1 bracket flat to the roof surface and attach to nut bracket with 16mm post Torx bolt, 2 s/s washer and 2 nylon washers. Nylon washers on inside.

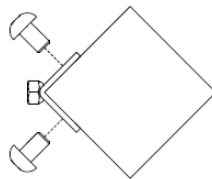

Attach the roof to the B1 bracket with bolts 10x15 C/H with Security caps and nuts M10.

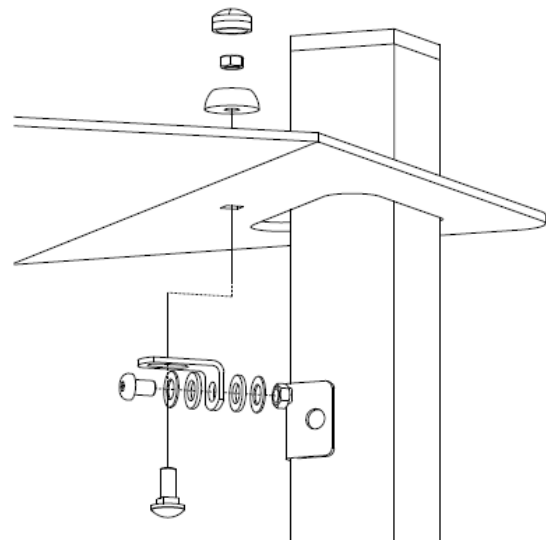

Tilt Roof

Brackets are preassembled to the roof.

Use 20mm tri-lobes to attach brackets to the roof.

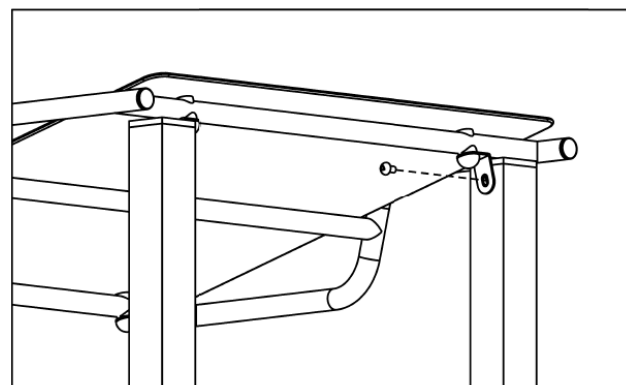

Pergola Roof Timber (double and quadruple)

Timber boards are screwed to the supporting angles and flat bars. Keep the roof in a square shape when attach to uprights. Attach plates to uprights with Trilobes 20. For the quadruple option join the angles with cargo plates, using Trilobes 17 and T Nuts.

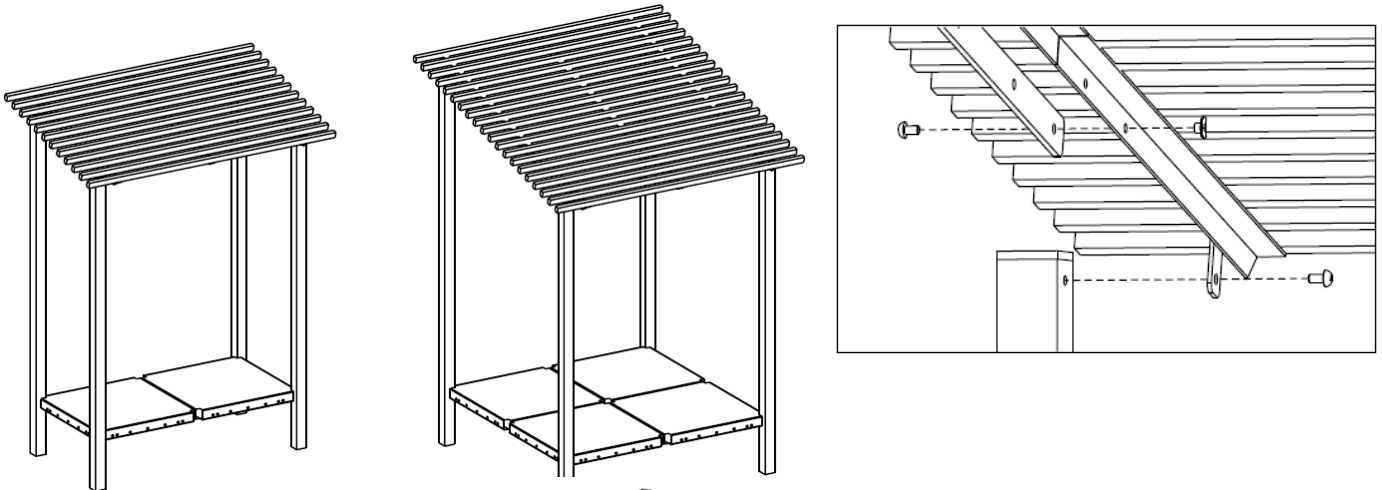

Slat Roof Aly / Timber (single, double and quadruple)

Attach Aly boards to angles using provided rivets 'Mega Lock'. Attach timber boards with provided 'screw-10-12x20mm' and security caps M6.

The first and last boards are the short ones.

Keep the roof in a square shape when attaching to uprights.

Attach angles to uprights with Trilobes 20.

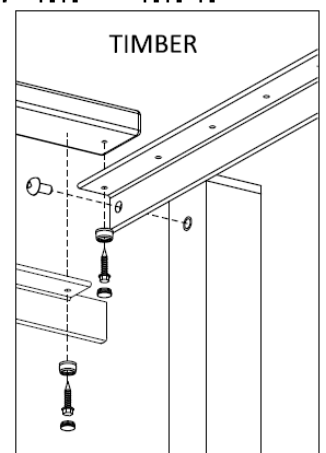
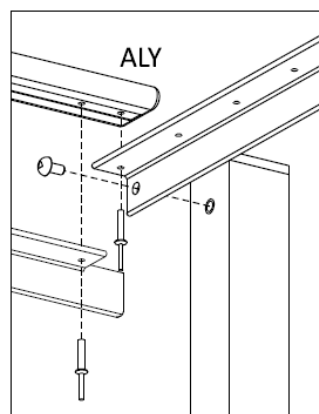
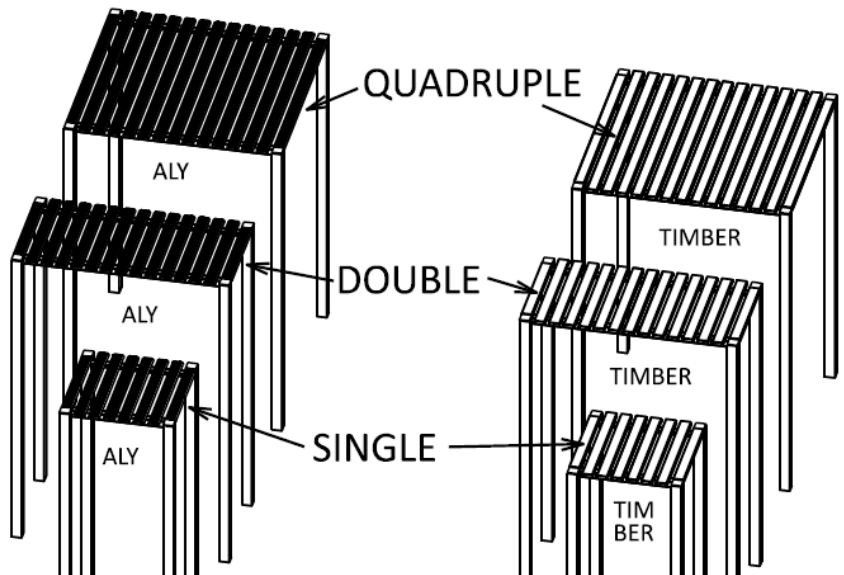

"S" Climber

Locate the correct position to mark and dig the hole in the ground and attach it to the platform using 17mm tri-lobes and T-nuts. 1200 and 1600 options have standard flange connections to uprights.

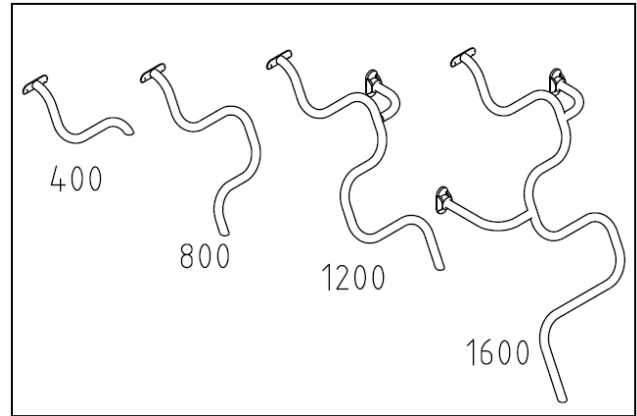
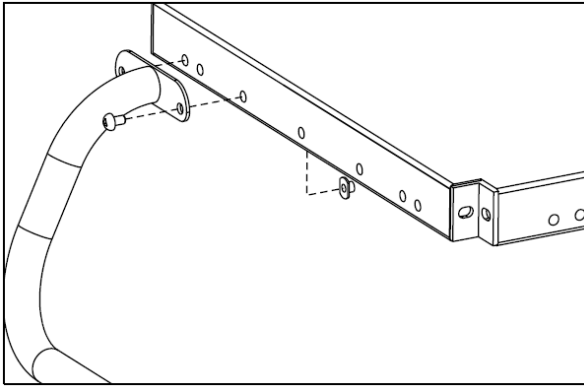

Rung / Roll Over Bar

Attach the flanges to the Rungs, and Roll Over Bars with a standard flange connection.

Concrete the leg of the roll-over bar into the ground.

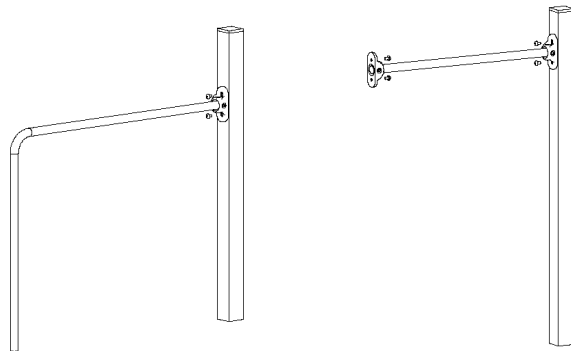

Rubber Seat

The rubber membrane, clamps, D shackles and corner plates are preassembled.

Attach plates to uprights with 17mm tri-lobes.

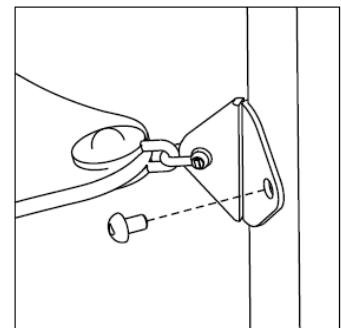
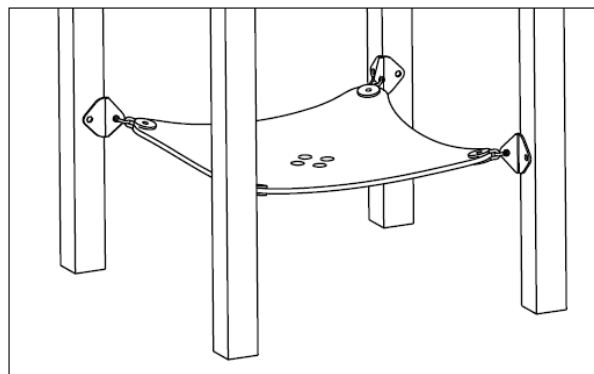

Slide – Straight, Wave, Curved, Double

IMPORTANT

When fitting a curved slide, spacers must be fitted between the handgrips and the metal section before assembly

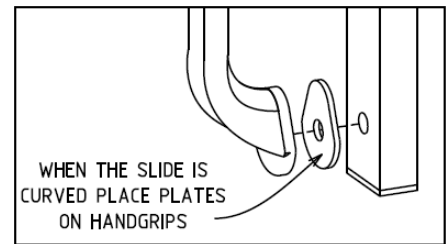

Locate the slide in its approximate position to determine the position of the holes for slide support legs and dig the holes. Curved slides and plastic 1600mm slides have a support leg halfway up the slide. Attach the slide leg(s) to the underside of the base of the slide using 17mm tri-lobes.

It is advisable to place a brick or a block of wood below each leg to provide additional stability. Concrete the legs into the ground. Attach the slide panel as described under “Panels (over)”. The bottom of the slide must sit at finished ground level.

Drill the 2 centre punch holes that are 30mm below platform level.

Attach the slide to the platform using 40mm tri-lobes entering from the underside of the platform into the slide with bed way of the slide level to the platform.

In some cases, due to the expanding nature of plastics, there may be a small gap between the rear of the slide and the platform. If this gap exceeds 3.5mm there is a risk of clothing becoming caught during use. If this gap occurs the bracket shown in the image should be fastened to either side of the slide, closing the outer opening of the gap. Fasten the bracket to the platform with pop rivets when the bracket is well pressed to the slide as per the image.

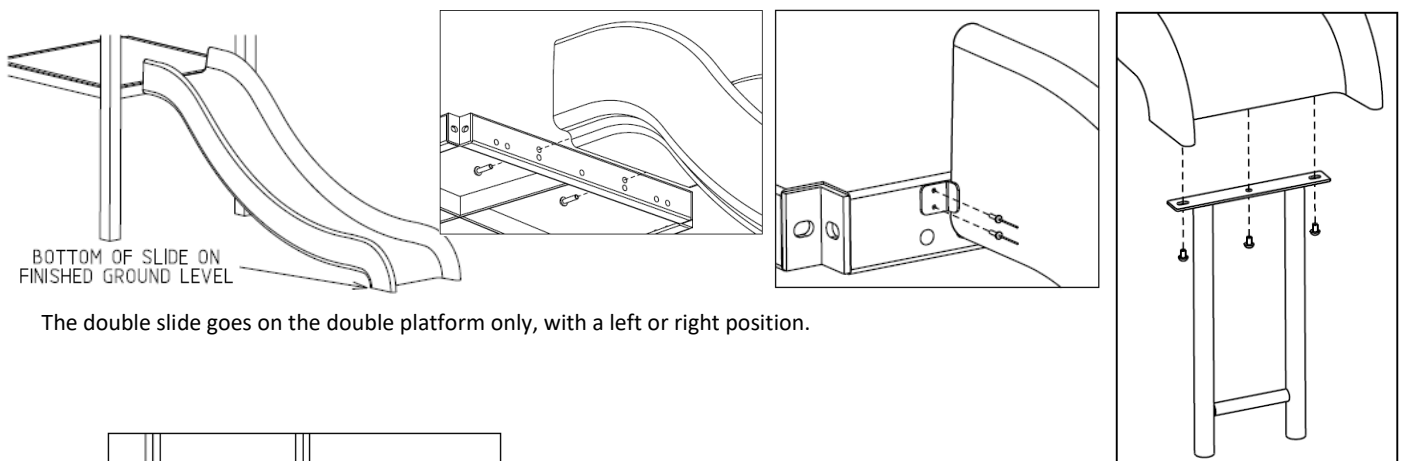

The double slide goes on the double platform only, with a left or right position.

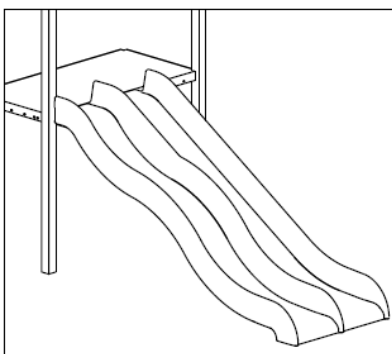

Spider Net

Use the top or bottom bar to determine the position of both upright holes. Dig the holes and insert the uprights ensuring that the underside of the bottom bar will sit 50mm above the finished ground surface. Attach the top and bottom bars to the uprights using 17mm tri-lobes. Attach the Spider Net to the top bars with M8x28 post Torx and the uprights using 20mm tri-lobes. Ensure that the uprights are vertical and then concrete into the ground.

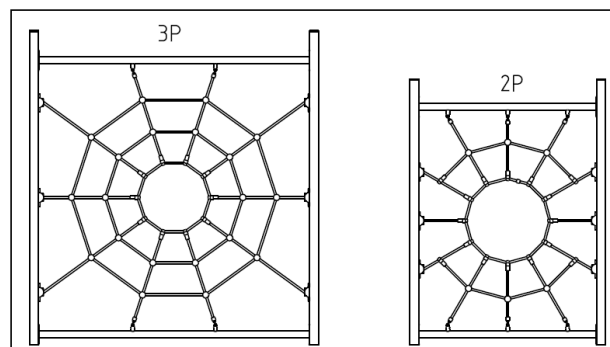

Spiral Tunnel Slides Under 2400

Spiral Tunnel slides don't have "No climbing" panels at the exit.

The slide is installed as detailed under "Slides – Tunnel (Straight)" with the following variations.

1. Additional support legs are used to support the slide. Where two tunnel sections connect the cradle connects to the lower side of the flange. The cradle at the exit of the slide connects on the underside, while the higher cradles attach to the side of the tunnel flanges in such a way that the support legs will point vertically down. Each leg should be installed with the base 600mm below the finished ground level. Use this as a guide to determine the point on the tunnel that each cradle attaches. All cradles are attached to the tube flanges using 30mm cup head bolts, nuts and security caps.
2. The orientation of each tunnel section is determined using a process referred to as "cranking". Cranking consists of placing the flanges of both sections together with the seams of the section to be attached and aligned to the seams of the previous section, and rotating it either clockwise or anti-clockwise by the required number of bolt holes in the flanges. (For example, 3 cranking steps would involve rotating the section by 3 bolt holes.) Note: Clockwise is determined while standing on the ground, facing up the slide.
3. In some instances, the exit section and legs may not finish in a vertical position, in these instances the plastic tunnel sections will need to be drilled to match the vertical position of the exit legs. Place the cradle flange with legs in a vertical position, mark and drill 5 new holes on plastic tubes and use these holes to join the cradle and tubes.

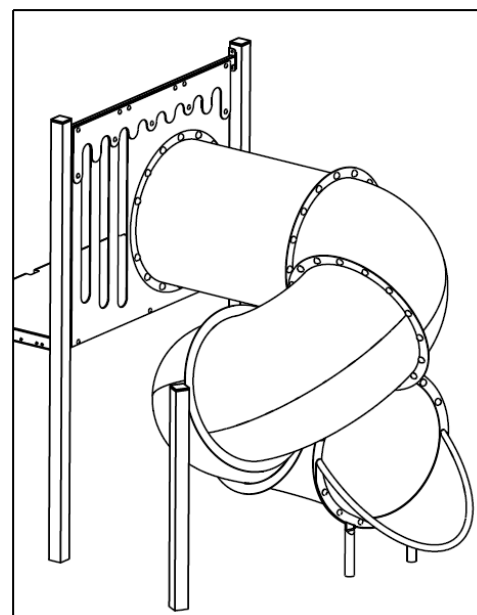

Begin by attaching the 1-meter straight section to the plastic entry panel with the seams of the tunnel vertical (top and bottom). Connect each following section in turn, aligning the seams to the previous section then rotating the section by the number of cranking steps as detailed below.

1200 Spiral Slide – Right (Reverse Direction for Slide Left)

Piece Number	Description	Cranking Steps	Direction
2	1st 90o elbow	3	Clockwise
3	2nd 90o elbow	1	Anti-clockwise
4	3rd 90o elbow	2	Anti-clockwise
5	4th 90o elbow	1	Anti-clockwise

1600 Spiral Slide – Right (Reverse Direction for Slide Left)

Piece Number	Description	Cranking Steps	Direction
2	1st 90o elbow	3	Clockwise
3	2nd 90o elbow	1	Anti-clockwise
4	3rd 90o elbow	2	Anti-clockwise
5	4th 90o elbow	2	Anti-clockwise
6	5th 90o elbow	1	Anti-clockwise

2000 Spiral Slide– Right (Reverse Direction for Slide Left)

Piece Number	Description	Cranking Steps	Direction
3	1st 90o elbow	3	Clockwise
4	2nd 90o elbow	3	Anti-clockwise
5	3rd 90o elbow	2	Anti-clockwise
6	35o elbow	5	Clockwise

Spiral Tunnel Slides Over 2400

2400 Spiral Slide– Right (Reverse Direction for Slide Left)

Piece Number	Description	Cranking Steps	Direction
3	1st 90o elbow	3	Clockwise
4	2nd 90o elbow	3	Anti-clockwise
5	3rd 90o elbow	2	Anti-clockwise
7	35o elbow	2	Clockwise

3000 Spiral Slide– Right (Reverse Direction for Slide Left)

Piece Number	Description	Cranking Steps	Direction
3	1st 90o elbow	3	Clockwise
4	2nd 90o elbow	3	Anti-clockwise
5	3rd 90o elbow	2	Anti-clockwise
6	4th 90o elbow	2	Anti-clockwise
7	45o elbow	2	Anti-clockwise
9	35o elbow	6	Clockwise

3400 Spiral Slide– Right (Reverse Direction for Slide Left)

Piece Number	Description	Cranking Steps	Direction
3	1st 90o elbow	3	Clockwise
4	2nd 90o elbow	3	Anti-clockwise
5	3rd 90o elbow	2	Anti-clockwise
6	4th 90o elbow	2	Anti-clockwise
7	45o elbow	2	Anti-clockwise
10	35o elbow	6	Clockwise

Spiral Tunnel Slide Barrier for Slides 2400 and Over

Attach rubber membrane to both supports with cup head bolts and security caps. Rise and position the frame above the tunnel flange you will attach the rubber. The flexible rubber will allow for both legs to keep a minimum distance of 250mm to the tunnel tube (no part of the tunnel should come closer than 250mm to the barrier support legs). The rubber should be tilted slightly forward of the exit as shown (check the dimensions). Mark the position for the holes in the ground. Dig the holes, insert the frame and bolt the rubber to the flange. If the last holes on the flange of the rubber don't match the holes on the tube's flange, drill the needed hole on the tube's flange. Concrete, keeping the frame vertical.

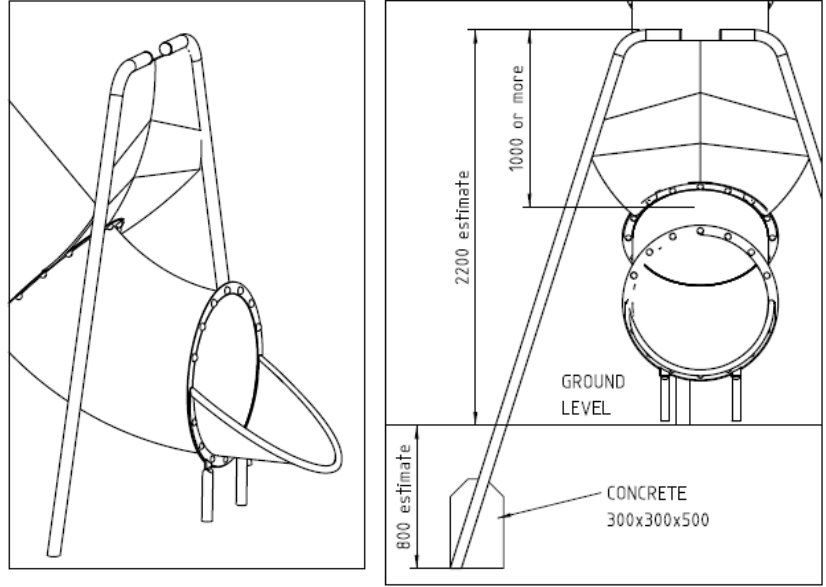

Slide Tunnel Plastic Curved 2000

The slide is installed as detailed under "Slide – Tunnel (Spiral)" with details of the cranking steps below.

Piece Number	Description	Cranking Steps	Direction
1	45o elbow	1	Clockwise
2	1st 35o elbow	2	Clockwise
5	2nd 35o elbow	5	Clockwise
6	3rd 35o elbow	2	Clockwise

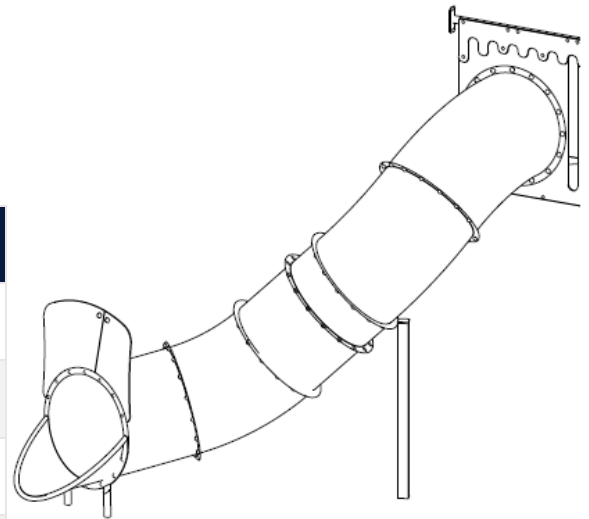

Slide Tunnel Plastic Curved 3400

The slide is installed as detailed under “Slide – Tunnel (Spiral)” with details of the cranking steps below.

Piece Number	Description	Cranking Steps	Direction
1	45o elbow	1	Clockwise
3	1st 35o elbow	3	Clockwise
6	2nd 35o elbow	7	Clockwise
7	3rd 35o elbow	1	Anti-clockwise

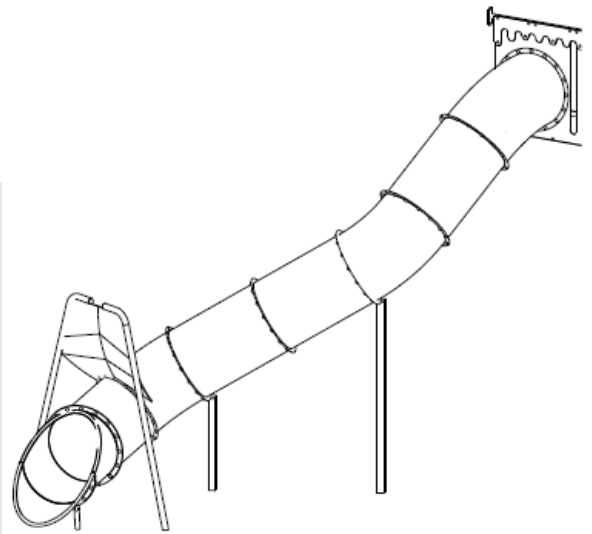

Slide – Tunnel Curved 2400

The slide is installed as detailed under “Spiral Tunnel Slides” with details of the cranking steps below.

Piece Number	Description	Cranking Steps	Direction
1	45o elbow	1	Clockwise
3	1st 35o elbow	2	Clockwise
5	2nd 35o elbow	5	Clockwise
6	3rd 35o elbow	2	Clockwise

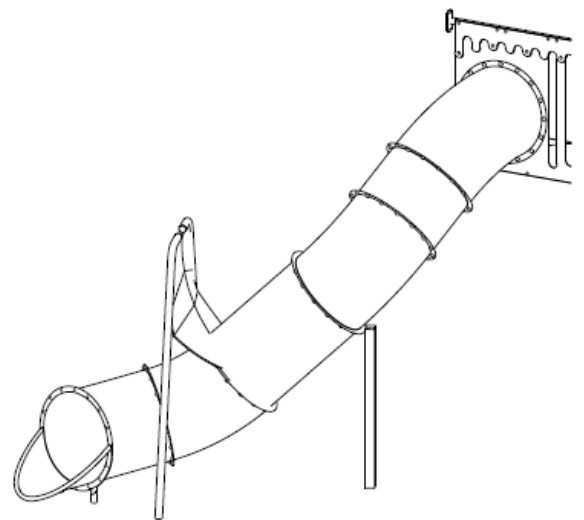

Stairs

Using the handrails as a guide, determine the distance from one platform to the next, and dig holes for the uprights at the end of the handrails. (For exact distances see “Determining Distances between Uprights” at the front of this manual.) Place the uprights in the holes and ensure that their depth is correct. Attach handrails with standard flange connection to uprights. Dig holes for the uprights on the connecting platform and attach the platform.

Join stairs to platforms using 17mm tri-lobes and T-nuts from the platform side. Join rails to uprights with 17mm tri-lobes.

Exclusion is the 800 Stairs to Ground - rails to uprights with standard poly flanges connection and bottom of stairs to rails with 17mm tri-lobes and T-nuts. The 1200 Stairs to Ground have a bracket attached with 17mm tri-lobes and T-nuts to the stairs and 17mm tri-lobes to the uprights.

Assemble side panels to handrails with bolts 10x25 C/H, nuts and security caps – panels with bolts on inside.

After ensuring that all bolts are tightened and that the platform and uprights are level and at the correct height concrete the footings in place.

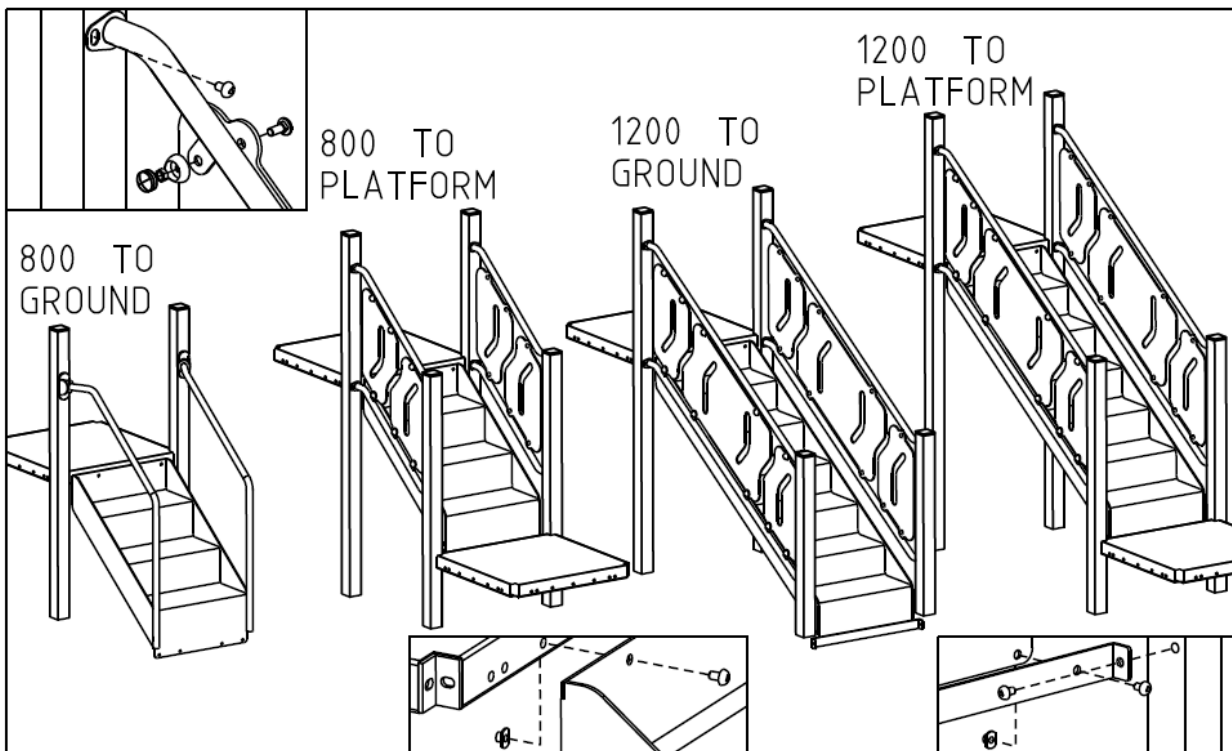

Step

Attach step to uprights using 4 B1 brackets and Trilobes 17.

Steppers 200/400/600

Fasten steppers to the uprights using 17mm tri-lobes. Dig the holes according to the plan for each stepper, ensuring the holes are no more than 600mm apart at the centre, or from the platform. Install the posts on the steppers at various heights, ensuring they are vertical, then concrete

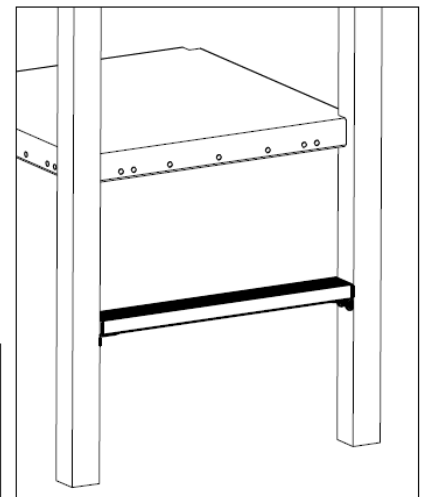
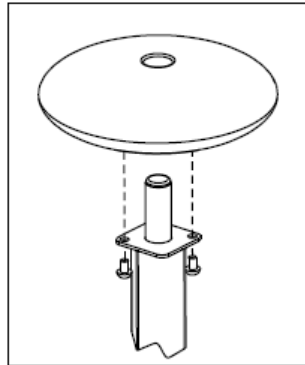

into the ground.

Step Crossing

Using the handrails as a guide, determine the distance between uprights, and dig holes for the uprights at the end of the handrails. (For exact distances see “Determining Distances between Uprights” at the front of this manual.) Place the uprights in the holes and ensure that their depth is correct. Attach the rails to the uprights using 20mm tri-lobes. Attach the platforms or end frame joiners to the uprights. After ensuring that the uprights are vertical, concrete them into the ground.

For timber boards, connect the ropes, boards and support chains as shown using 50mm Torx bolts with 3/8” washers.

For Aly boards use cap nuts and stud M10x32.

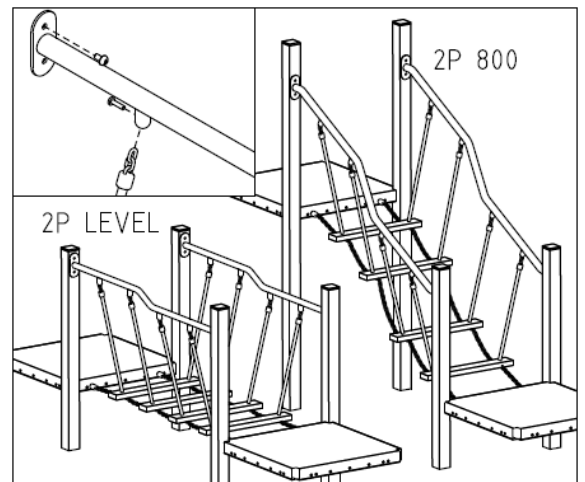

Connect the top of each rope to the rails using “chain housing connections”. Connect ends of chains to chain housings with M8 Torx bolts and the chain housings to platforms with square washer and 17mm tri-lobes as shown. Apply Loctite on all bolts and nuts.

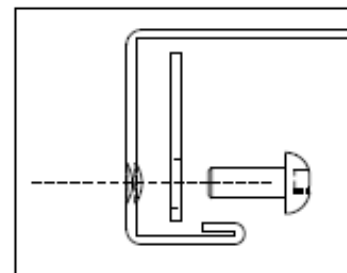
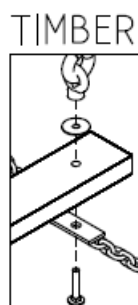
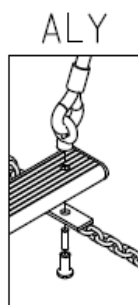
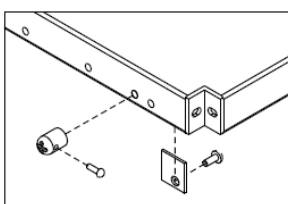

Step Ladder 800

Attach the flanges to the handrails (as detailed in “flanges” on page 5 of this manual), then using the handrails as a guide mark the position of the handrails on the ground and dig two holes. Loosely attach it to the uprights using 20mm tri-lobes. Attach the top step to the platform using 17mm tri-lobes from the platform side. Assemble the steps bolting the aluminium steps to the side rails using 17mm tri-lobes. Each side rail has a hole in the lower end for attaching the handrail for bolt 70 Post Torx. The top step has two holes on the back side for attaching to the platform. When all bolts have been tightened, concrete the handrails into the ground.

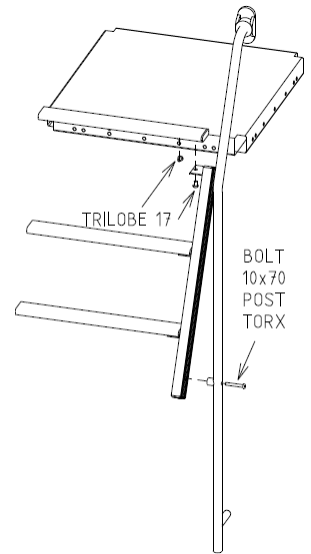

Step Traverse

Attach pommels to step frame using 17mm tri-lobes. Using either the handrails or step frame as a guide, determine the distance from one platform to the next and dig the holes for the uprights. (For exact distances see “Determining Distances between Uprights” at the front of this manual.) Place the uprights in the holes and ensure that their depth is correct. Use a standard flange connection to attach the frames to uprights. Attach the uprights at the opposite end. After ensuring that all bolts are tightened and that the platform and uprights are level and at the correct height concrete the footings in place.

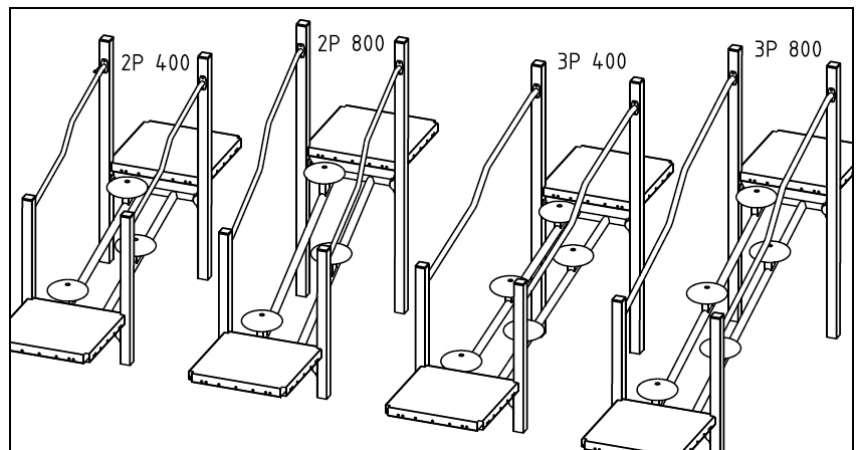

Stepping Stones - 2P, 2P Inc. 800,

3P and 3P Inc. 800

Attach pommels to step frame using 17mm tri-lobes. Using either the top rail or step frame as a guide, determine the distance from one platform to the next and dig the holes for the uprights. (For exact distances see “Determining Distances between Uprights” at the front of this manual.) Place the uprights in the holes and ensure that their depth is correct. Attach the flanges to the top rail and step frame (as detailed in “flanges” on page 5 of this manual), then attach to the uprights using 20mm tri-lobes. Attach the platform and uprights at the opposite end. After ensuring that all bolts are tightened and that the platform and uprights are level and at the correct height concrete the footings in place. Connect the ropes to the top bar (as detailed under “chain housing connections” on page 5 of this manual).

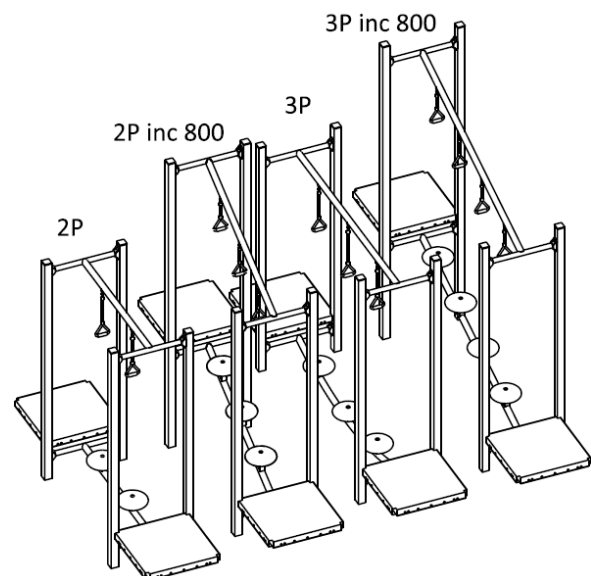

The 3P option has a longer middle rope.

Tube Net

Use a standard flange connection to attach the rail to uprights, according to the plan. The rope ends with the chain to rail with 8x28 post Torx. Standard connection of flanges to uprights. The bottom 2 ropes with eye nuts go to the platforms with a square washer and 17mm tri-lobes from inside of the platforms.

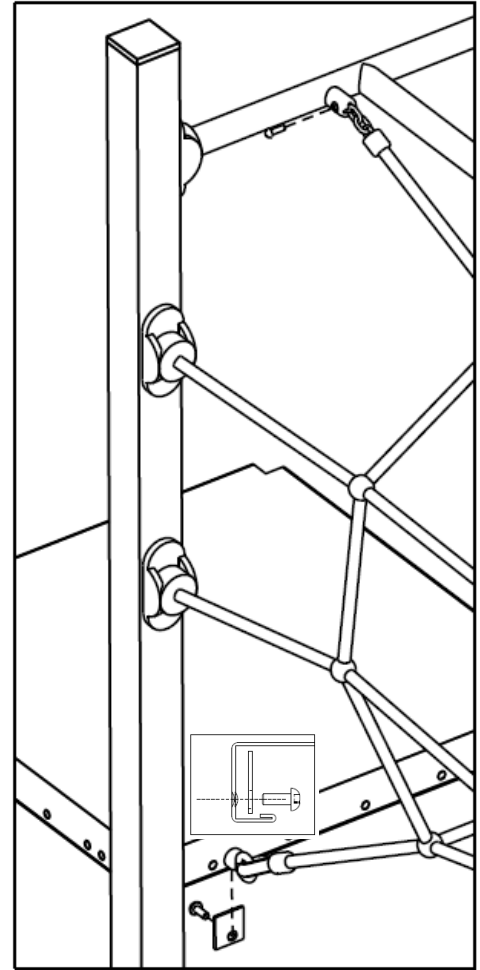
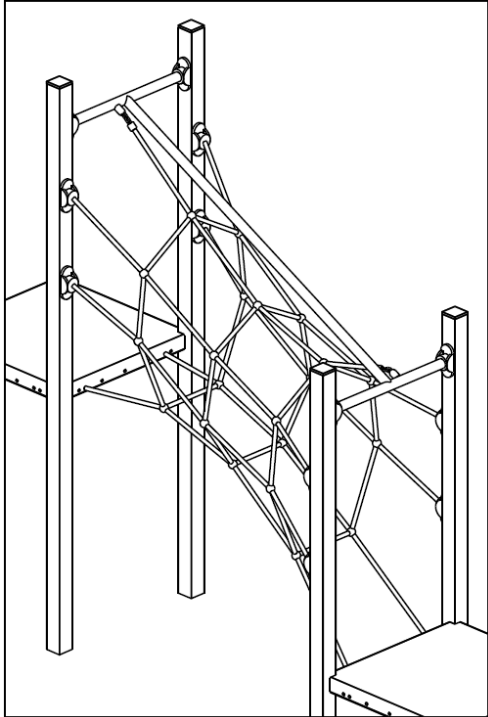

Tunnel 1P/2P (Aly)

The 1P has 1 part 'panel and tunnel' and another panel only. Connect them with Trilobes 17 and security caps with nuts. The lower part is attached to platforms Trilobes 17 and T nuts. The 2P option has 2 parts 'panel and tunnel' joined with Trilobes 17 and security caps with nuts.

The upper part is attached to uprights with a panel support plate.

When it is UNDER position, it is rotated. The upper part is attached to the platforms and the lower part is to the support plate.

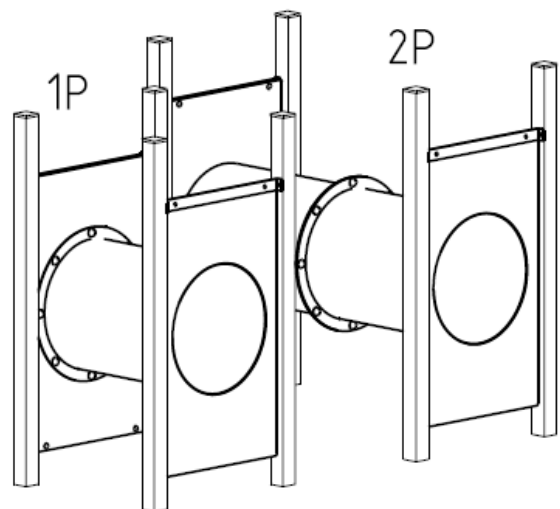

Tunnel 1P/2P (plastic panels)

Connect the Aly tunnel to plastic panels with L brackets. Brackets to the plastic panel with trilobes 40 when 2 panels and bolt 30 Post Torx when 1 panel. Brackets to tunnel with Trilobes 20. Use security caps + nuts on opposite sites. Panels to B1 bracket with Bolt C/H 30 and security caps + nuts on top and to uprights with Trilobes 20. To platform on the bottom with Trilobes 25 and T nuts.

When it is UNDER position, there is a support plate on the lower part, attached to panels with Trilobes 20 and T nuts, and with Trilobes 20 to uprights.

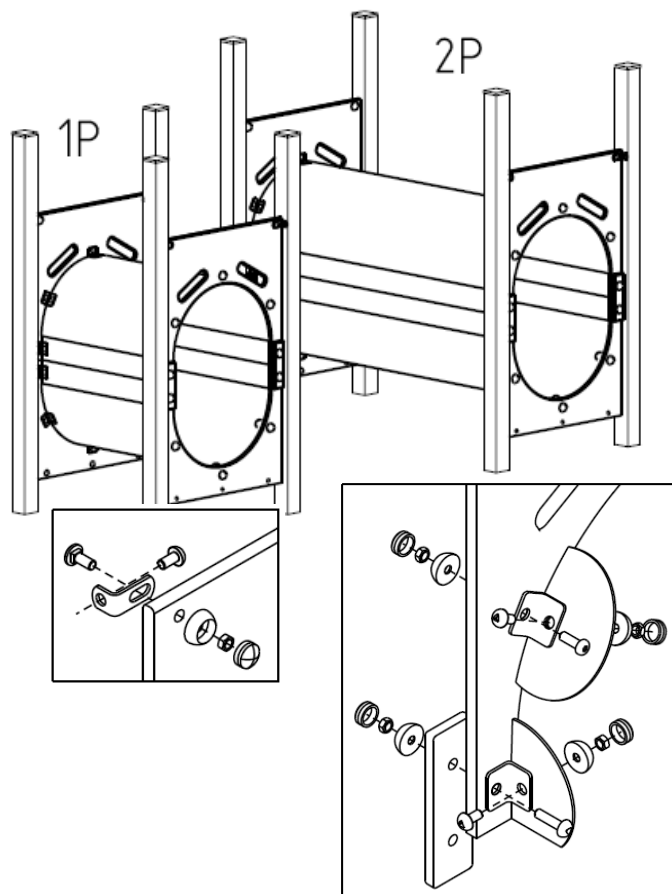

Tunnel Slides

Attach the slide panel to the platform and uprights as detailed under “Panels (over platform) - ENTRANCE TUNNEL PANEL”.

Connect the sections of the tunnel slide using 10x25 C/H bolts (except where the slide leg cradle attaches - 10x30 C/H bolts), nuts and security caps as shown. Connect the top section to the entry panel and keep going down, section after section. Check the plan for the type of slide and the number and type of sections. Attach the slide legs to the support cradle using ‘tap tight’ trilobes. Each leg should be installed with the base 600mm below the finished ground level.

Use the slide as a guide to determine the position of the holes for the exit support legs and dig holes. It is advisable to place a brick or a block of wood below each leg to provide additional stability. Concrete the legs into the ground.

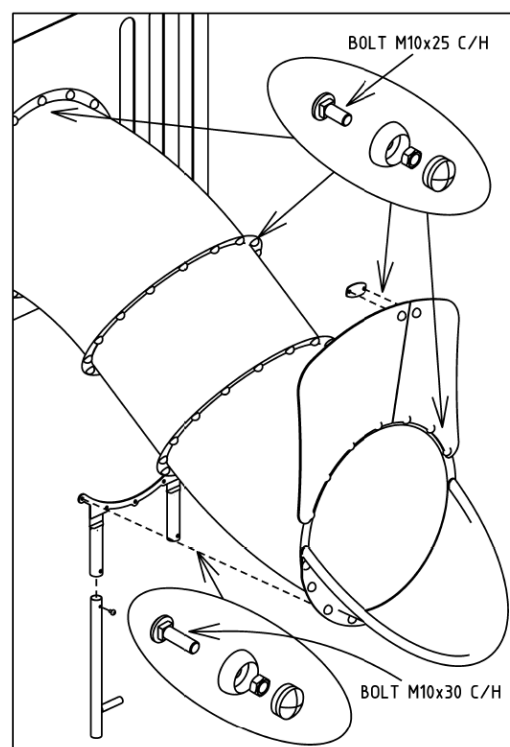

Tunnel Slide – Supports

Check the plan for the position and number of supports. Here is a list of support positions per individual slides:

Tunnel slide 2400 – second flange, under

Tunnel slide 1200/1600 35/45/90deg – first flange, under

Spiral Tunnel slide 1200 – third flange, on side

Spiral Tunnel slide 1600 – second and fourth flange, on side

Spiral Tunnel slide 2400 – second, fourth and sixth flange, on side

Slide Tunnel Plastic Curved 2400 - third flange, under

Attach the joining plate to the upright with tri-lobes 10 x 17.

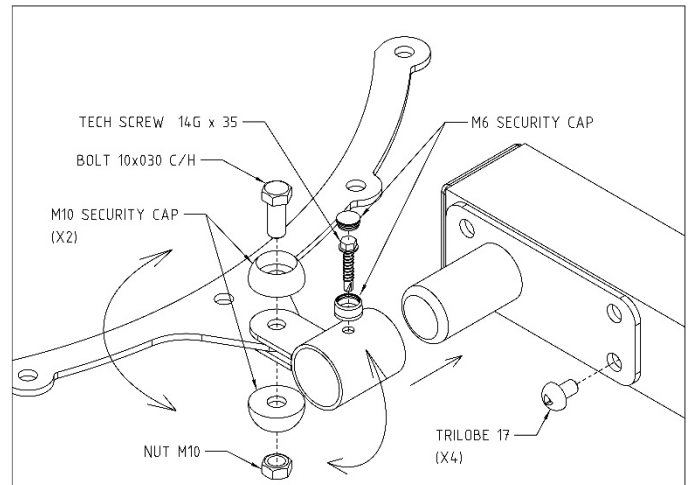

Position the upright from either under or on the outside section of the flange and attach the cradle in a suitable position. Join the plug to the cradle with a loose bolt. Insert the plug on the plate's pipe and secure it with the Tec Screw.

Tighten the bolt and place the cover on the caps.

Voice Pipe

Voice Pipes are attached directly to the uprights using 17mm tri-lobes.

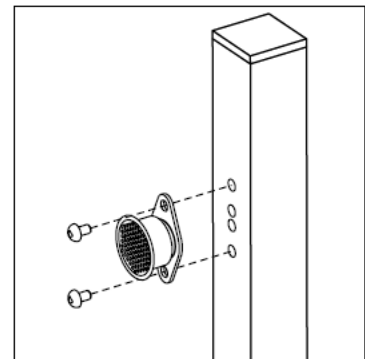

Walkways

Using a platform as a guide, determine the distance from one platform to the next, and dig holes for the uprights at the end of the handrails. (For exact distances see “Determining Distances between Uprights” at the front of this manual.) Place the uprights in the holes and ensure that their depth is correct. Attach handrails with standard flange connection to uprights. Dig holes for the uprights on the connecting platform and attach the platform.

Join the platforms with legs using 17mm tri-lobes and T-nuts from the platform side. Assemble side panels to handrails with bolts 10x25 C/H, nuts and security caps – panels with bolts on inside. Assemble the aluminium boards to legs with 40mm tri-lobes, or timber boards with 40mm tri-lobes, cap nuts di cast and washer ½". The 2 shorter boards are the first and last ones. On inclined Walkways Timber, the first

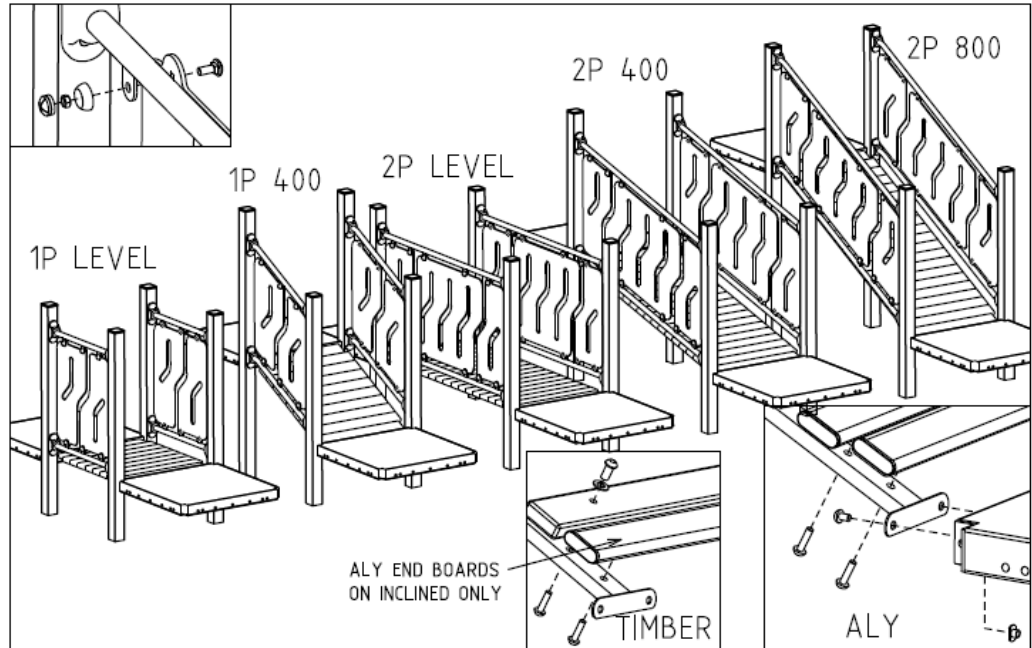

and last boards are aluminium. Check all gaps between boards that should be less than 8mm and all gaps between rails and panels should be more than 25mm to avoid finger entrapments.

After ensuring that all bolts are tightened and that the platform and uprights are level and at the correct height concrete the footings in place.

Web Tunnels

Attach the upper steel flanges of the frame to the uprights using 20mm tri-lobes. The lower part of the frame and rope ends to uprights are using standard flange connection. Attach the top of the rope ends to the housings on the frame with M8x28 post Torx. Attach ropes with eye nuts to the platform using a square washer and 20mm tri-lobes. Attach the web tunnel anchors to the chains at the

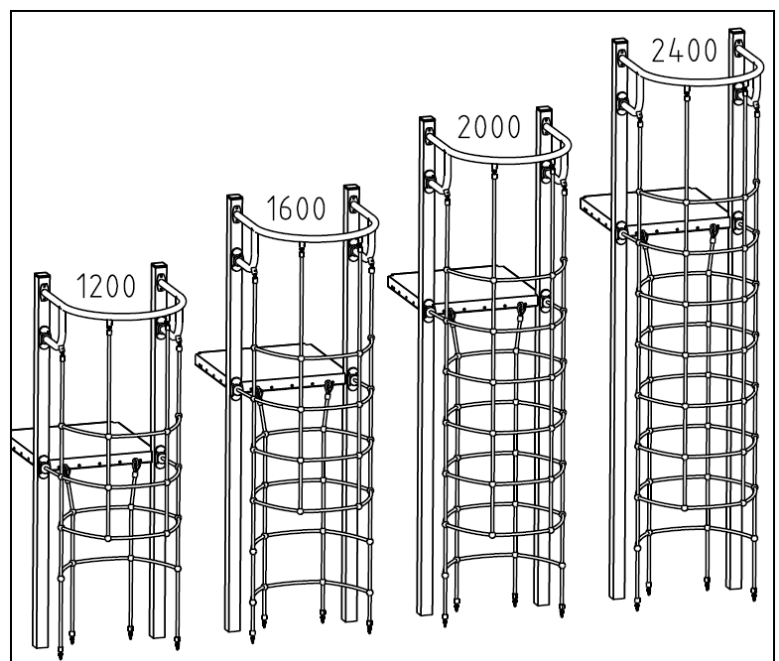
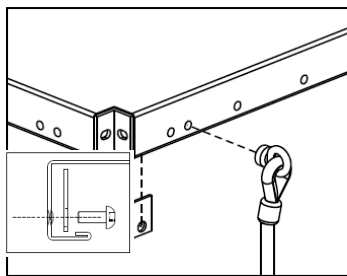

base of the ropes. Dig 4 holes below the web tunnel for the chain anchors. The concrete of the uprights and anchors can be joined. Ensure the ropes and chains are taut and concrete the anchors into the ground.

Web Walls

Below Platform

Attach the rope to the platform using a square washer and 20mm tri-lobe. Attach the rail to uprights with a standard flange connection. Attach side rope ends to the uprights using a standard flange connection and M8x28 post Torx on the bottom rope.

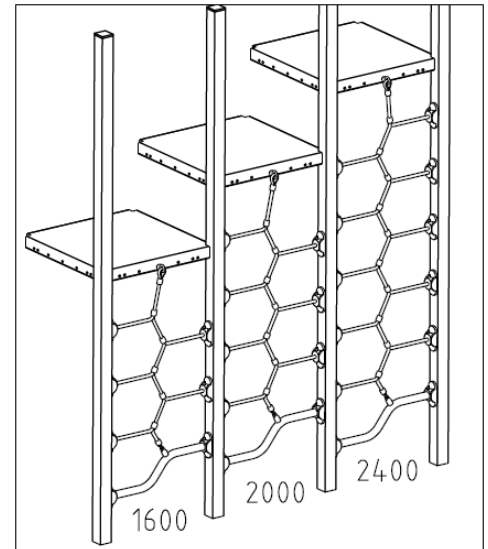
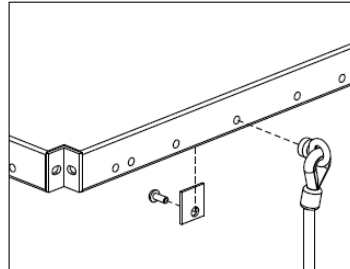
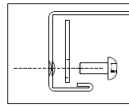

Wobble Walker 3P

Position the top bar on the ground with the first end level with the uprights it will connect to. Mark the spot for the next two uprights, dig the holes and insert the uprights to the correct height. Attach the flanges to the top bar (as detailed in “flanges” on page 5 of this manual), then lift into place and attach to the uprights using 20mm tri-lobes. Ensure that the bolts are tightened.

Attach the adjoining platforms and then concrete the uprights into the ground.

Connect the ropes to the top bar (as detailed under “chain housing connections” on page 5 of this manual).

Attach the ends of chains to platforms with chain housings and Trilobes 20 with square plates from the platform side.

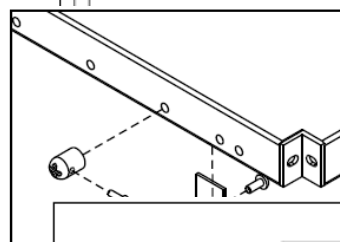
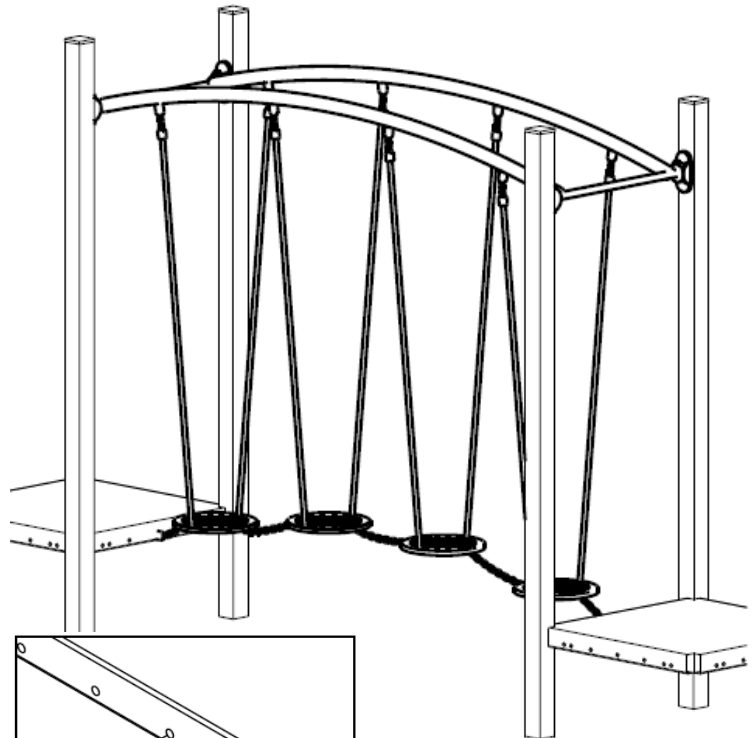

Z Balance Beam – 2P and 3P

Attach the flanges to the legs (as detailed in “flanges” on page 5 of this manual), then attach them to the balance beam using tap-tight tri-lobes.

Using the balance beam to determine the hole positions dig holes 700mm deep. Insert the legs into the holes and after ensuring the beam is level and 30mm away from the platform, concrete into the ground.

These items are not attached to platforms or uprights.

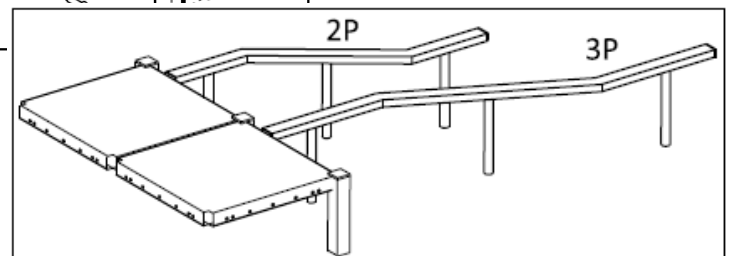

Before Leaving the Site

- Check that all bolts are tightened.
- Check that all concrete footings are 300mm below the finished surface level where loose-fill material is used.
- Check that the structure is solid with all uprights secure in the ground.
- Check your Softfall, ensuring that your fall zones and the depth of the Softfall are correct.
- Touch up any scratches on the paintwork.
- Remove all rubbish and packaging from the site.

Safety and Maintenance Inspections

To ensure that your equipment remains in a safe condition, we recommend that you establish a schedule of safety and maintenance inspections and record the details of your inspections in a logbook. In this manner, any minor repairs are done as soon as they are required, and your equipment will remain in a safe condition. In the event of an accident occurring on your play equipment, your records of these inspections are proof that your 'duty of care' has been maintained.

We recommend that your play equipment be inspected with varying degrees of detail on a frequency basis as outlined on the following page.

Any spare parts that may be required for your play equipment will be available through your local Forpark Australia branch, and our sales staff will be able to help you with any queries you may have regarding your equipment.

Please remember! Play equipment that is well maintained remains safe and will last for many years.

Routine Visual Inspection

Frequency – At least weekly. Daily inspections may be required where loose fill surfacing is used or in cases where the equipment is subject to heavy use or vandalism.

Surfacing

- Check that the soft-fall surfacing area is free of debris and contamination.
- Check that displacement of your loose-fill surfacing material has not resulted in areas becoming shallower than the recommended depth, particularly below items of equipment where falls are likely. Such areas should be levelled or filled to ensure that the recommended depth is maintained.

Equipment

- Check for vandalism, and any damaged or missing parts. In the event of any damage or missing parts, isolate the play equipment until repairs have been carried out.

Operational Inspection

Frequency – Every one (1) to three (3) months, depending on the level of use. Equipment subject to heavy use or vandalism may need to be inspected more frequently. Any problems identified should be addressed on a priority basis taking into account any safety implications.

Surfacing & Surrounds

- Check that the soft-fall surfacing area is free of debris and contamination.

- Check that a loose fill soft-fall surfacing is at the recommended depth, and top up if necessary.
- Check that a synthetic surface is in good condition and securely in place to provide impact absorption.
- Check that any soft-fall surfacing borders are secure in the ground, do not constitute trip points, and have no rough or sharp edges.
- Check the area for overgrown bushes or hazards that may have intruded into the play area over time.

Equipment

- Check all fasteners and tighten and replace any that are missing.
- Check that all uprights and components are secure in the ground and that no footings are showing through the soft-fall.
- Check steel play equipment for rust or corrosion. (All metal play equipment will show some signs of breakdown over time, and this may be exacerbated by a marine environment.) Replace any badly corroded parts.
- Check timber equipment for splintering and warping; and coat with Sikksens Cetol Mahogany if required. Replace any damaged items.
- Check all moving parts for excessive wear, and replace any worn items.
- Check all chain links for wear and replace any damaged items.
- Check for any bending or cracking of steel components and replace them where necessary.
- Check all paintwork, and touch up any areas that are worn or chipped.
- Large rope net structures with tensioning aids (e.g., turn buckles) need to be checked for sufficient tension and re-tensioned if necessary.
- In highly corrosive environments it is strongly recommended that all equipment is regularly washed with clean water to prevent any build-up of rust-causing minerals. This is particularly important where the equipment is positioned under a permanent shade structure and cannot be naturally washed by rain.
- Check for any grease points and apply Molycoat Long Term grease to all grease nipples.

Comprehensive Inspection

Frequency – Annually. Yearly it is advisable to have your equipment checked by someone who is qualified in playground equipment maintenance, or by an engineer.

Surfacing & Equipment

- In addition to a detailed inspection of all areas covered in an “Operational Inspection”, the following checks should be made.
- Check the structural integrity of equipment subject to corrosion or rotting.
- Check for any changes in the safety of the equipment resulting from repairs made, or added or replaced components