

Timber Bridge Small

A-NAT-2214 • A-NAT-2414



Specifications

Age range: All ages

Number of play elements: 4

Equipment size: 1322 x 713mm

Equipment height: 806mm

Fall zone: N/A

Max fall height: N/A

Play Types



Materials

Material specs

Frame: Ironbark Timber / Spotted Gum Timber / Galvanised Post

Fasteners: Stainless Steel

Powder Coating: Dulux / Interpon

Timber Bridge Small - SF

A-NAT-2214

Elevation

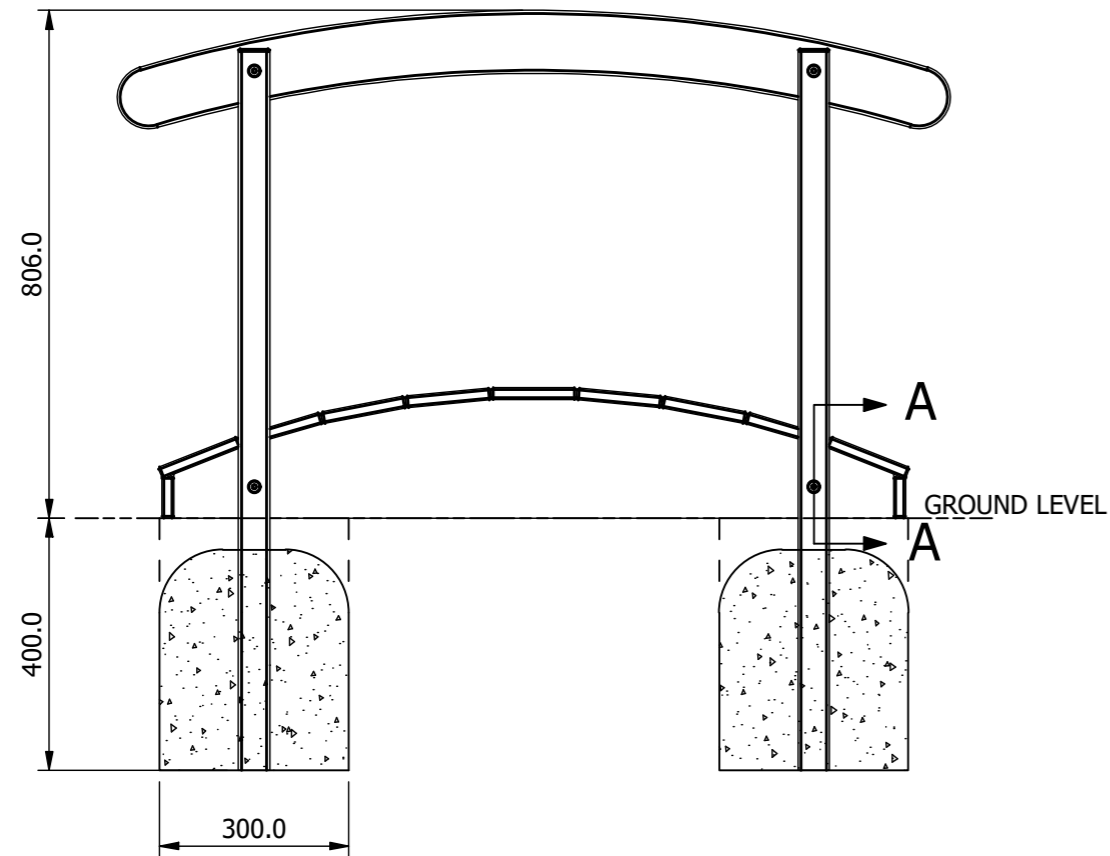

Plan View

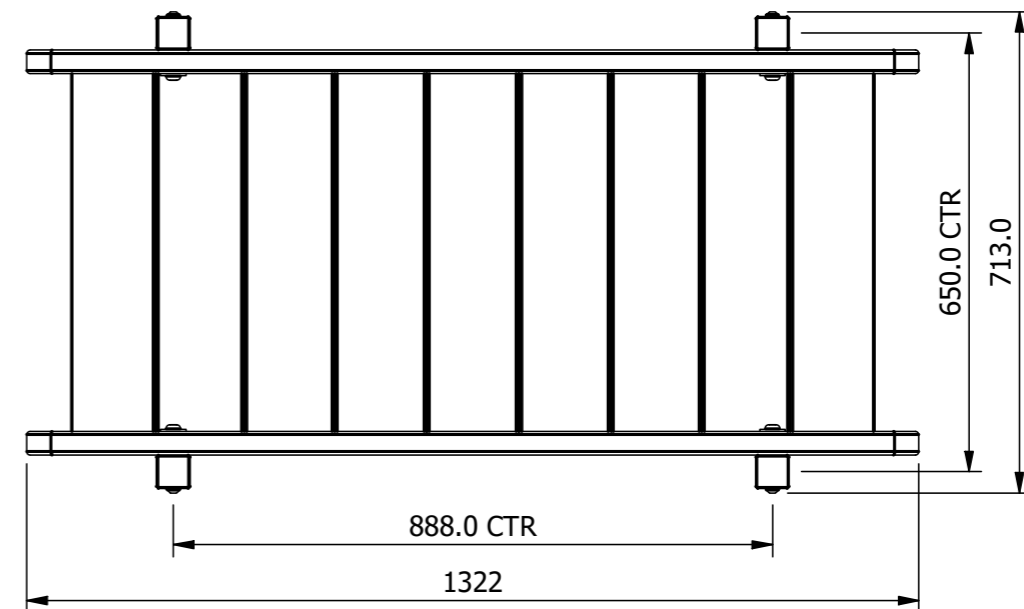

Please Note

Our Natura Play Elements ranges are made as original pieces, not mass-produced. The character of each piece will be affected by the individual timber available at the time of production. The above image should be used as a guide only. Whilst care is taken to select the best materials, timber is a natural material that is expected to seasonally expand and contract over time and when subjected to temperature extremes. We use Ironbark and Cypress timber in our designs, Cypress timber in particular is prone to fine checking and knots are very common. Accordingly, timbers supplied may have checks and knots that are not structurally compromising.

Timber Bridge Small - SM

A-NAT-2414

Elevation

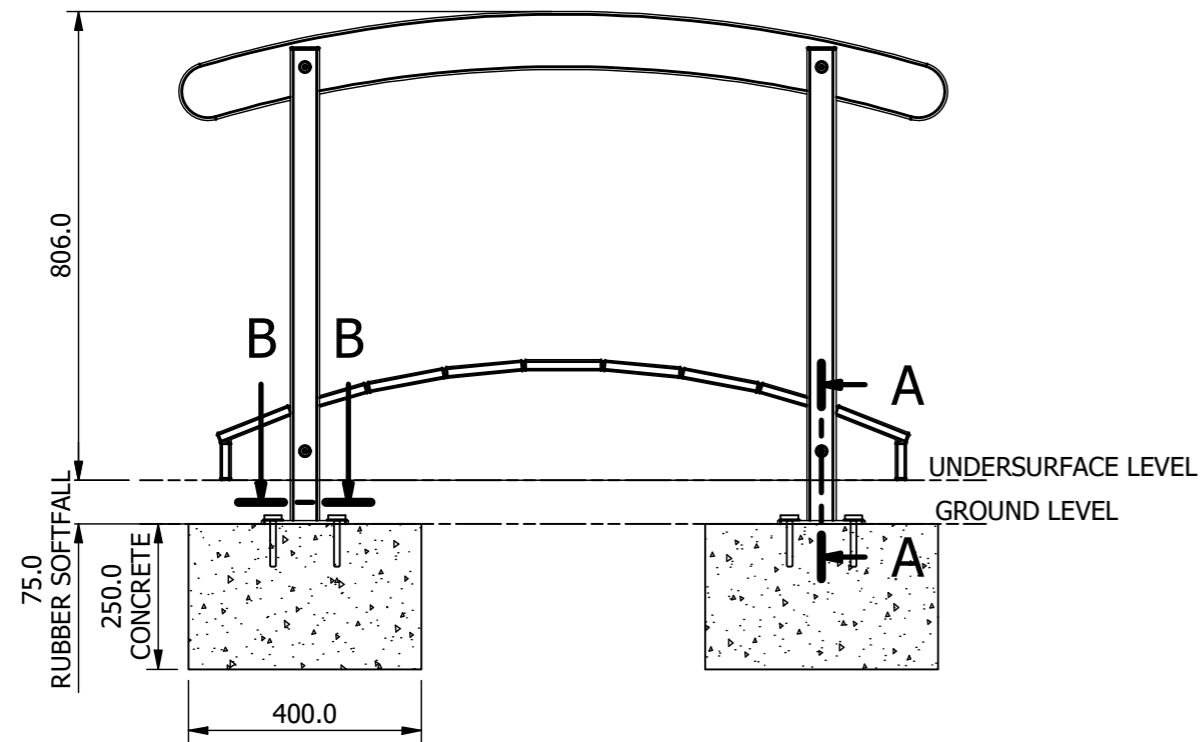

Plan View

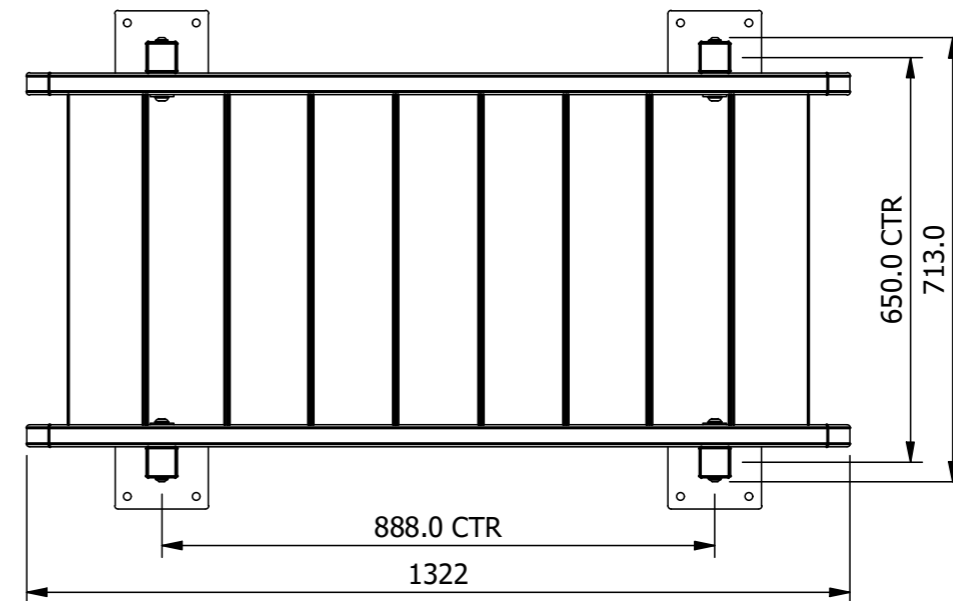

Please Note

Our Natura Play Elements ranges are made as original pieces, not mass-produced. The character of each piece will be affected by the individual timber available at the time of production. The above image should be used as a guide only. Whilst care is taken to select the best materials, timber is a natural material that is expected to seasonally expand and contract over time and when subjected to temperature extremes. We use Ironbark and Cypress timber in our designs, Cypress timber in particular is prone to fine checking and knots are very common. Accordingly, timbers supplied may have checks and knots that are not structurally compromising.